



PowerBook Duo Dock

PowerBook Duo Dock, PowerBook Duo Dock II,
PowerBook Duo Dock Plus





Basics

PowerBook Duo Dock





System Overview

PowerBook Duo System

The PowerBook Duo system includes the following products:

- PowerBook 200 Series computer (PowerBook Duo 210/230/250/270c/280/280c)
- PowerBook Duo Dock/Duo Dock II/Duo Dock Plus
- PowerBook Duo MiniDock
- Floppy Adapter

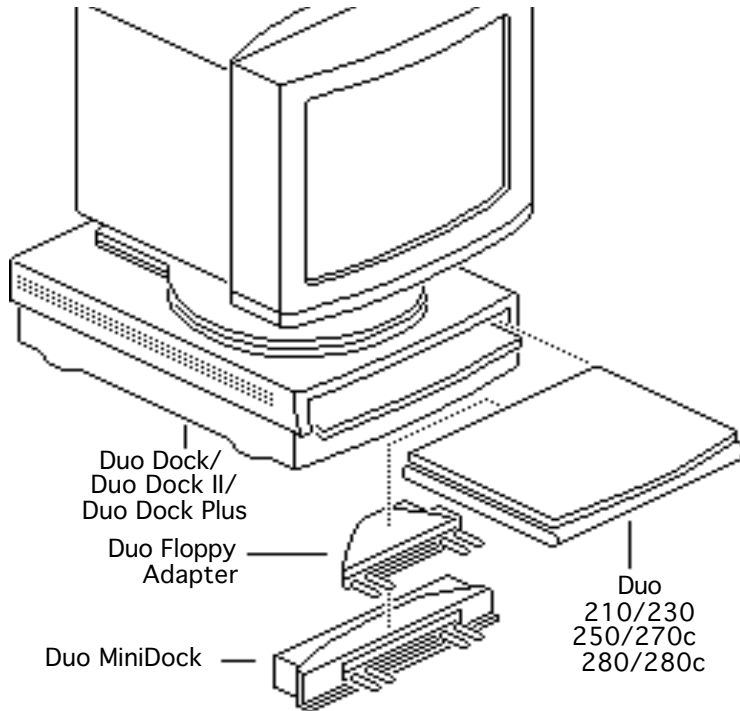



Figure: PowerBook Duo Dock, Duo Dock II, Duo Dock Plus

This manual includes information about the Duo Dock, Duo Dock II, and Duo Dock Plus, shown at left.

For information about the floppy adapter and the PowerBook 200 Series computers, refer to the PowerBook 200 Series manual. For information about the Duo MiniDock, refer to the PowerBook Duo MiniDock manual.





Repair Strategy

Service the PowerDuo Dock, Duo Dock II, and Duo Dock Plus through module exchange and parts replacement. Customers can request on-site service from an Apple Authorized Service Provider Plus (AASP+) Apple Assurance (US only), or request a courier through the Apple Canada Technical Answerline (Canada only). They can also choose carry-in service from an AASP.

Ordering

Apple Service Providers planning to support the products covered in this manual may purchase Service modules and parts to develop servicing capability. To order parts, use the AppleOrder (US only) or ARIS (Canada only) system and refer to “Service Price Pages.”





Large businesses, universities, and K-12 accounts must provide a purchase order on all transactions, including orders placed through the AppleOrder (US only) or ARIS (Canada only) system.

USA Ordering

US Service Providers not enrolled in AppleOrder may fax their orders to Service Provider Support (512-908-8125) or mail them to

Apple Computer, Inc.
Service Provider Support
MS 212-SPS
Austin, TX 78714-9125

For US inquiries, please call Service Provider Support at 800-919-2775 and select option #1.





Canadian Ordering

Canadian Service Providers not enrolled in ARIS may fax their orders to Service Provider Support in Canada (1-800-903-5284). For Canadian inquiries, please call Service Provider Support at 905-513-5782 and select option #3.





Warranty/AppleCare/ARIS

US Only

The PowerBook Duo Dock, Duo Dock II, and Duo Dock Plus are covered under the Apple One-Year Limited Warranty. The AppleCare Service Plan is also available for these products. Service Providers are reimbursed for warranty and AppleCare repairs made to these products. For pricing information, refer to “Service Price Pages.”

Canada Only

The PowerBook Duo Dock, Duo Dock II, and Duo Dock Plus are covered under first-year AppleCare. The Extended AppleCare Service Plan is also available for these products. Service Providers are reimbursed for first-year warranty and Extended AppleCare repairs made to these products. For pricing information, refer to “Service Price Pages.”





Duo Dock Configurations

The Duo Dock is available in standard and enhanced configurations. The enhanced configuration includes:

- 230 MB hard drive
- Math coprocessor (68882 FPU chip at 25 MHz)
- 512K VRAM SIMM
- ADB Mouse II





These items are options for the standard configuration of the original Duo Dock. See the Specifications chapter for more information.

The Duo Dock II is available in this standard configuration:

- Math coprocessor (68882 FPU chip) at 33MHz
- On-board Ethernet
- 1 MB VRAM SIMM
- ADB Mouse II

The Duo Dock Plus has the same features as the Duo Dock II, but without the FPU and cache.





SCSI Devices

SCSI ID Numbers

The PowerBook Duo Dock supports up to six SCSI devices. To avoid conflicting SCSI ID numbers, assign external SCSI devices numbers between 2 and 6. (The hard drive inside the PowerBook Duo has SCSI ID number 0, and, if installed, the hard drive inside the Duo Dock has ID number 1.)

Note: You must use an HDI-30 SCSI system cable to connect external SCSI devices to the Duo Dock.

Caution: When making SCSI connections, always switch off power to all devices in the chain.





SCSI Termination

The PowerBook Duo Dock has a built-in SCSI terminator.

To terminate a SCSI chain connected to the dock, attach one external terminator only to the last device in the chain, or connect a SCSI device with built-in termination as the last device in the chain.

Note: SCSI devices from other vendors may have built-in terminators. If a SCSI device with a built-in terminator is the last device in the chain, do not add an external terminator to that device. If more than one SCSI device in the chain has built-in terminators, you may need to remove the extra internal terminators.





Specifications

PowerBook Duo Dock





Introduction

You can also find specifications information for this product in the Spec Database, which you can access in one of three ways:

- Launch it directly by double-clicking the Apple Spec Database runtime alias at the top level of the Main Service Source CD.
- Select "Apple Spec Database" from the Service Source drop-down main menu.
- Click the Acrobat toolbar icon for the database, which is near the right end of the toolbar with the letters "SP."





Processor

Coprocessor, Duo Dock

Motorola 68882 FPU chip (optional for standard Duo Dock)
25 MHz

Coprocessor, Duo Dock II

Motorola 68882 FPU chip and 32K RAM cache
33 MHz

Addressing

32-bit internal registers
32-bit address bus
32-bit data bus





Memory

ROM	Configuration ROM (differentiates between docking devices)
VRAM Duo Dock	512K of VRAM soldered on logic board 512K VRAM SIMM (optional for standard Duo Dock)
VRAM Duo Dock II/ Duo Dock Plus	1 MB of VRAM soldered on logic board; no slot for additional VRAM expansion





Disk Storage

Floppy Drive

Internal 1.4 MB floppy drive
SWIM II MFM/GCR disk controller chip

Hard Drive, Duo Dock/Duo Dock II

230 MB, 3.5 in., 1-in.-high SCSI hard drive (optional for Duo
Dock)
Internal 50-pin SCSI connector; external HDI-30 SCSI port





I/O Interfaces

Docking Connector

Internal 152-pin processor-direct slot (PDS) connector to PowerBook
32-bit expansion bus

SCSI

HDI-30 SCSI port with 1.5 MB/sec. transfer rate
Supports up to six external SCSI devices (five if drive is installed)
Includes built-in terminator
Connection to another computer requires HDI-30 SCSI system cable

Apple Desktop Bus

Apple Desktop Bus (ADB) port (recommend maximum of three low-speed, synchronous ADB devices); mini DIN-4 connector
200 mA maximum current draw for all ADB devices





Serial	Two RS-422 serial ports; mini DIN-8 connectors
NuBus	Two internal NuBus slots Two 15 W cards, or one each at 25 W and 5 W
Ethernet	One internal Ethernet port (on Duo Dock II/Duo Dock Plus only)
Sound	Monaural sound-in port (requires 20 dB attenuation cables and adapters to accommodate audio equipment with line level outputs) Monaural sound output jack for external audio amplifier
Video	DB-15 connector supports Macintosh and some VGA monitors (requires 15-pin-to-VGA adapter)





Modem

Pass-through telephone jack for optional internal (PowerBook) modem

RJ-11 domestic; mini DIN-8 international





I/O Devices

Keyboard

Apple Keyboard II
Apple Extended Keyboard

Mouse

Apple Desktop Bus mouse
ADB Mouse II

Microphone

External electret, omnidirectional microphone
Output voltage of 4 mV, peak to peak

Speaker

16 Ω magnetic, moving coil speaker





Video Support Duo Dock

512K of built-in video plus a 512K VRAM SIMM
Supports all Macintosh monitors up to 16-in. color
Supports VGA monitors (requires NuBus card)
1 MB of VRAM supports up to 32,000 colors

Video Support Duo Dock II/Duo Dock Plus

1 MB of on-board VRAM
Supports most Macintosh monitors (including Apple Multiple Scan monitors) up to 21-in. color
Supports some VGA monitors
Includes Sync On Green feature





Electrical

Power Supply Duo Dock

Universal AC power supply, 85–270 VAC
Provides 75 W continuous power, 85 W surge power
47–63 Hz, single phase input line frequency
Charges PowerBook Duo batteries and powers Duo Dock

Power Supply Duo Dock II/Duo Dock Plus

Universal AC power supply, 90–270 VAC
Provides 75 W continuous power, 85 W surge power
47–63 Hz, single phase input line frequency
Charges PowerBook Duo batteries and powers Duo Dock I or II





Physical

Dimensions Duo Dock

Height: 4.75 in. (121 mm)

Width: 12.25 in. (311 mm)

Depth: 16.25 in. (413 mm)

Dimensions Duo Dock II/Duo Dock Plus

Height: 6.22 in. (158 mm)

Width: 12.75 in. (323.8 mm)

Depth: 16.37 in. (415.6 mm)

Weight Duo Dock

13.1 lb. (5.95 kg) without hard drive; frame supports up to 60 lb.

Weight Duo Dock II/Duo Dock Plus

15 lb. without hard drive; frame supports up to 85 lb.





Environmental

**Operating
Temperature Duo
Dock**

50–104° F (10–40° C)

**Operating
Temperature Duo
Dock II/Duo Dock
Plus**

50–95° F (10–35° C)

**Storage
Temperature**

-40 to 116° F (-40 to 47° C)

Relative Humidity

20–95% noncondensing





Altitude

0-15,000 ft. (0-4722 m)





Other

Modem

Telephone line interface (DAA) circuitry (domestic)

Support for external telephone line interface (DAA) circuitry
(international)

RJ-11 connector (domestic); mini DIN-8 connector
(international)

Docking Motor

Motorized injection/ejection mechanism draws the PowerBook Duo system into the Duo Dock and ejects the system from the Duo Dock

DC motor operates at 5 rpm and provides 16–30 lb. of pull-in force





Security

Key locking device at left front of unit locks PowerBook Duo computer into the Duo Dock

Each lock is unique (no master key is available); 125 key combinations

Key codes will be released to locksmiths

Hook at rear of monitor stand can be used with Kensington mechanism to lock Duo Dock to the desktop





Troubleshooting

PowerBook Duo Dock





General

The Symptom Charts included in this chapter will help you diagnose specific symptoms related to your product. Because cures are listed on the charts in the order of most likely solution, try the first cure first. Verify whether or not the product continues to exhibit the symptom. If the symptom persists, try the next cure. (Note: If you have replaced a module, reinstall the original module before you proceed to the next cure.)

If you are not sure what the problem is, or if the Symptom Charts do not resolve the problem, refer to the Flowchart for the product family.

For additional assistance, contact Apple Technical Support.





Hard Drives May Not Spin Up

When inserted into a Duo Dock or Duo Dock II+, your PowerBook 200 Series computer may not start from its internal hard drive.

The conditions that can cause the problem include:

- The PowerBook 200 Series (Duo) computer and Duo Dock hard drives have been formatted with different versions of HD SC Setup.
- Enough VRAM is installed to allow the option of thousands of colors when the PowerBook 200 Series computer is inside the Dock (unless thousands of colors are selected, the problem does not occur).
- 32-bit addressing is on.

It can also occur with an external hard drive connected to the Dock, or if a third party drive is installed inside the Duo Dock or Duo Dock II+. In this case, reformatting both the PowerBook 200





Series computer and the Dock drives with the appropriate formatter is required. Because Apple HD SC Setup does not recognize third party drives, you need to use a third party formatter.

To correct the problem, remove one of these conditions:

- Use HD SC Setup 7.2.2 or later to update the drivers on both hard drives. This is available from authorized dealers or on-line services.
- Reformat the Powerbook 200 Series computer's hard drive with Apple HD SC Setup 7.1, or reformat both the Duo's internal hard drive and the Dock's hard drive with the same version of HD SC Setup.
- Turn off 32-bit addressing.
- When starting up from the Dock, set the colors to 256 instead of thousands.

Source: Info Alley, June 1995





Symptom Charts

Startup

RAM failure occurs
(eight-tone error
chord sequence
sounds after startup
chord)

- 1 Eject PowerBook Duo. Reboot and troubleshoot computer only.
- 2 Replace Duo Dock logic board. Retain VRAM SIMM, math coprocessor, and SCSI terminator.





Hardware failure occurs (four-tone error chord sequence sounds after startup chord)

- 1 Eject PowerBook Duo. Reboot and troubleshoot computer only.
- 2 Disconnect hard drive data cable, install standard Apple SCSI terminator, and reboot system. If startup sequence is normal, reseal cable, remove terminator, and retest. If failure recurs, replace hard drive.
- 3 Disconnect floppy drive cable and reboot system. If startup sequence is normal, reseal cable and retest. If hardware failure recurs, replace floppy drive.
- 4 Replace Duo Dock logic board. Retain VRAM SIMM, math coprocessor, and SCSI terminator.





Power

System doesn't respond

- 1 Eject PowerBook Duo. Reboot and troubleshoot computer only.
- 2 Check all Duo Dock logic board cable connections.
- 3 Replace Duo Dock power supply.
- 4 Replace Duo Dock logic board. Retain VRAM SIMM, math coprocessor, and SCSI terminator.

System intermittently crashes or locks up

- 1 Make sure system software is 7.1 or higher.
- 2 Make sure software is known-good.
- 3 Eject PowerBook Duo. Reboot and troubleshoot computer only.
- 4 Replace Duo Dock logic board. Retain VRAM SIMM, math coprocessor, and SCSI terminator.
- 5 Replace Duo Dock power supply.





System doesn't power up, power supply makes ticking sound, and display has no raster

- 1 Measure to see if voltages for pins 5 and 7 on the power supply-to-logic board cable fall between the following ranges:
 - Pin 5 (yellow wire) 5V + or - .5V
 - Pin 7 (blue wire) 20V + or - .5V
- 2 If voltages don't fall within the above ranges, replace Duo Dock power supply.





Video

No external display,
but computer
appears to operate
correctly

- 1 Adjust screen contrast.
- 2 Reseat video cable.
- 3 Replace video cable.
- 4 Replace video interface card (if installed).
- 5 Replace VRAM SIMM (if installed).
- 6 Try known-good external display. If now OK, replace and troubleshoot original display.
- 7 Replace Duo Dock logic board. Retain VRAM SIMM, math coprocessor, and SCSI terminator.





Raster or video display problems at external monitor

- 1 Reseat video cable.
- 2 Replace video cable.
- 3 Replace video interface card (if installed).
- 4 Replace VRAM SIMM (if installed).
- 5 Try known-good external display. If now OK, replace and troubleshoot original display.
- 6 Eject PowerBook Duo. Reboot and troubleshoot computer only.
- 7 Replace Duo Dock logic board. Retain VRAM SIMM, math coprocessor, and SCSI terminator.





Floppy Drive

Audio and video present, but internal floppy drive does not operate

- 1 Try known-good floppy disk.
- 2 Check floppy drive cable connection.
- 3 Replace floppy drive cable.
- 4 Replace floppy drive.
- 5 Replace Duo Dock logic board. Retain VRAM SIMM, math coprocessor, and SCSI terminator.

Disk ejects while booting; display shows Mac icon with blinking X

- 1 Try known-good system disk.
- 2 Verify that mouse button is not stuck.
- 3 Check floppy drive cable connection.
- 4 Replace floppy drive cable.
- 5 Replace floppy drive.
- 6 Replace Duo Dock logic board. Retain VRAM SIMM, math coprocessor, and SCSI terminator.





Disk does not eject

- 1 Switch off system. To eject disk, hold mouse button down while you switch system on.
- 2 Insert straightened paper clip into hole next to drive opening and eject disk.
- 3 Check floppy drive cable connection.
- 4 Replace floppy drive cable.
- 5 Replace floppy drive.
- 6 Replace Duo Dock logic board. Retain VRAM SIMM, math coprocessor, and SCSI terminator.

Disk initialization fails

- 1 Verify that you are using correct media.
- 2 Try known-good floppy disk.
- 3 Check floppy drive cable connection.
- 4 Replace floppy drive cable.
- 5 Replace floppy drive.





Read/write/copy
error

- 1 Verify that you are using correct media.
- 2 Try known-good floppy disk.
- 3 Check floppy drive cable connection.
- 4 Replace floppy drive cable.
- 5 Replace floppy drive.





Hard Drive

Internal PowerBook hard drive does not operate

Eject PowerBook Duo. Reboot and troubleshoot computer only.

Internal Duo Dock hard drive does not operate

- 1 Check internal hard drive data cable connection.
- 2 Replace internal hard drive data cable.
- 3 Run Macintosh Hard Disk Test.
- 4 Use HD SC Setup to reinitialize drive.
- 5 Replace internal hard drive.
- 6 Replace Duo Dock logic board. Retain VRAM SIMM, math coprocessor, and SCSI terminator.





Internal hard drive works, but external SCSI device does not

- 1 Make sure external devices have unique switch settings between 2 and 6.
- 2 Make sure SCSI chain is terminated at last device only.
- 3 Replace external SCSI terminator.
- 4 Troubleshoot external SCSI device.

Drive does not appear on desktop

- 1 Restart system.
- 2 Verify that SCSI devices have unique addresses.
- 3 Use HD SC Setup to initialize drive.





Peripherals

Cursor does not move, or moves erratically

- 1 Simultaneously press <Command> <Control> <Power On> keys to reset computer.
- 2 Check ADB connections.
- 3 Inspect and clean mouse, if necessary.
- 4 If mouse was connected to keyboard, try in ADB port. If OK, replace keyboard.
- 5 Replace mouse.
- 6 Replace Duo Dock logic board. Retain VRAM SIMM, math coprocessor, and SCSI terminator.

Cursor moves, but clicking mouse button has no effect

- 1 Replace mouse.
- 2 Replace Duo Dock logic board. Retain VRAM SIMM, math coprocessor, and SCSI terminator.





No response to any key on keyboard

- 1 Press <Power On> key or power button.
- 2 Check keyboard cable connection.
- 3 Replace keyboard cable.
- 4 Replace keyboard.
- 5 Replace Duo Dock logic board. Retain VRAM SIMM, math coprocessor, and SCSI terminator.

Cannot double-click to open application, disk, or server

- 1 Remove any multiple system files.
- 2 Inspect and clean mouse, if necessary.
- 3 Clear parameter RAM and reset mouse controls. To clear PRAM, start system, listen for boot tone, and immediately depress <Option> <Command> <P> and <R> keys.
- 4 If mouse was connected to keyboard, try in ADB port. If OK, replace keyboard.
- 5 Replace mouse.
- 6 Replace Duo Dock logic board. Retain VRAM SIMM, math coprocessor, and SCSI terminator.





After you connect external SCSI device, computer doesn't boot

- 1 Switch on external SCSI device before starting computer.
- 2 Check cable connections.
- 3 Verify that standard Apple terminator terminates SCSI chain.
- 4 Verify that SCSI select switch setting on external device is unique.
- 5 Verify operation of internal hard drive.
- 6 Try known-good external SCSI device.
- 7 Replace Duo Dock logic board. Retain VRAM SIMM, math coprocessor, and SCSI terminator.

Known-good ImageWriter, ImageWriter II, or LQ does not print

- 1 Verify that System is 7.1 or later.
- 2 Verify that Chooser and Control Panel settings are correct.
- 3 Check cables.
- 4 Replace printer interface cable.
- 5 Try known-good printer.
- 6 Replace Duo Dock logic board. Retain VRAM SIMM, math coprocessor, and SCSI terminator.





- | | |
|--|---|
| Known-good LaserWriter does not print | <ol style="list-style-type: none">1 Verify that System is 7.1 or later.2 Verify that Chooser and Control Panel settings are correct.3 Check cables.4 Replace printer interface cable.5 Try known-good printer. If printer works, troubleshoot network. Refer to Networks manual.6 Replace Duo Dock logic board. Retain VRAM SIMM, math coprocessor, and SCSI terminator. |
| Device connected to external modem port doesn't work | <ol style="list-style-type: none">1 Verify that External Modem is selected in PowerBook Control Panel.2 Verify that System is 7.1 or later.3 Check cables.4 Test device with known-good computer.5 Eject PowerBook and test device at PowerBook external modem/printer port.6 Replace Duo Dock logic board. Retain VRAM SIMM, math coprocessor, and SCSI terminator. |





I/O devices are unrecognized or garbage is transmitted or received

- 1 Verify that System is 7.1 or later.
- 2 Check cables.
- 3 Verify that SCSI devices are terminated properly.
- 4 Verify that SCSI select switch setting on external device is unique between 2 and 6.
- 5 Test device with known-good computer.
- 6 Replace Duo Dock logic board. Retain VRAM SIMM, math coprocessor, and SCSI terminator.





Internal Modem

Internal modem options do not appear in CDEV

- 1 Verify that System is 7.1 or later.
- 2 Remove and reseal modem interface board.
- 3 Eject PowerBook and test internal modem.
- 4 Replace modem interface board.
- 5 Replace Duo Dock logic board. Retain VRAM SIMM, math coprocessor, and SCSI terminator.





Modem does not respond properly to AT command set instructions

- 1 Verify that baud rate and data format settings of communications application are compatible with internal modem and remote modem.
- 2 Check phone cord connection and operation.
- 3 Verify that System is 7.1 or later.
- 4 Remove and reseal modem interface board.
- 5 Eject PowerBook and test internal modem.
- 6 Replace modem interface board.
- 7 Replace Duo Dock logic board. Retain VRAM SIMM, math coprocessor, and SCSI terminator.





Strange mix of characters appears on screen

- 1 Verify that baud rate and data format settings of communications application are compatible with internal modem and remote modem.
- 2 Check phone cord connection and operation.
- 3 Verify that System is 7.1 or later.
- 4 Remove and reseal modem interface board.
- 5 Eject PowerBook and test internal modem.
- 6 Replace modem interface board.
- 7 Replace Duo Dock logic board. Retain VRAM SIMM, math coprocessor, and SCSI terminator.

Modem interferes with system sound

- 1 Remove and reseal modem interface board.
- 2 Eject PowerBook and test internal modem.
- 3 Replace modem interface board.
- 4 Replace Duo Dock logic board. Retain VRAM SIMM, math coprocessor, and SCSI terminator.





Modem does not respond to incoming call

- 1 If computer is in sleep mode, verify that “Answer calls” is selected in Remote Access Setup control panel.
- 2 Check phone cord connection and operation.
- 3 Eject PowerBook and test internal modem.
- 4 Replace modem interface board.
- 5 Replace Duo Dock logic board. Retain VRAM SIMM, math coprocessor, and SCSI terminator.

Modem has no sound output

- 1 Verify that Control Panel volume setting is 1 or higher.
- 2 Eject PowerBook and test internal modem.
- 3 Replace modem interface board.
- 4 Replace Duo Dock logic board. Retain VRAM SIMM, math coprocessor, and SCSI terminator.

Modem connects but does not communicate with remote modem

- 1 Verify that remote modem needs error correction (error correction is internal modem default).
- 2 Type AT &Q0 to disable error correction.





Miscellaneous

Can't insert
computer into dock

- 1 Unlock dock and insert computer.
- 2 Open I/O door on computer and insert computer.
- 3 Replace ejector assembly.
- 4 Replace Duo Dock logic board. Retain VRAM SIMM, math coprocessor, and SCSI terminator.

Can't eject computer
from dock

- 1 Unlock dock and press eject button again.
- 2 If no power to dock, insert dock's key or small screwdriver into square hole on side of dock and press to manually eject computer.
- 3 Replace ejector assembly.
- 4 Replace Duo Dock logic board. Retain VRAM SIMM, math coprocessor, and SCSI terminator.





No sound from
speaker

- 1 Verify that volume setting in Control Panel is 1 or above.
- 2 Check speaker-to-logic board cable connection.
- 3 Replace Duo Dock logic board. Retain VRAM SIMM, math coprocessor, and SCSI terminator.

Ejects computer
when you attempt to
start up from
keyboard

Shut down PowerBook and insert again.





Take Apart

PowerBook Duo Dock



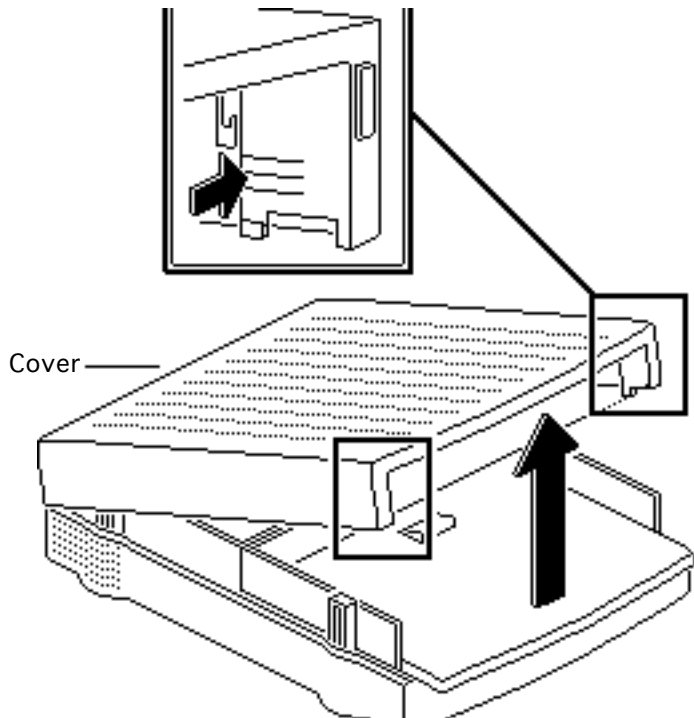

Cover

Before you begin,

- Shut down unit
- Eject PowerBook Duo
- Disconnect cables

- 1 Pinch the cover at the horizontal grooves inside the front of the cover and raise the cover to a 45-degree angle.





- 2 Lift the cover straight up and remove it from the base.

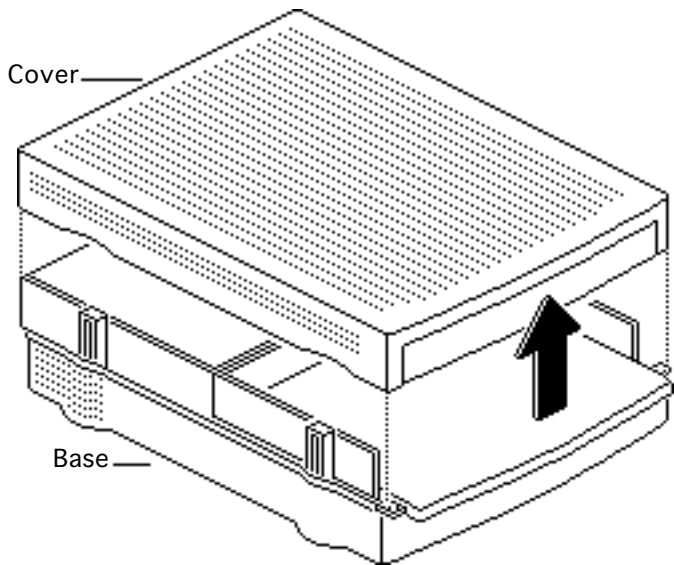

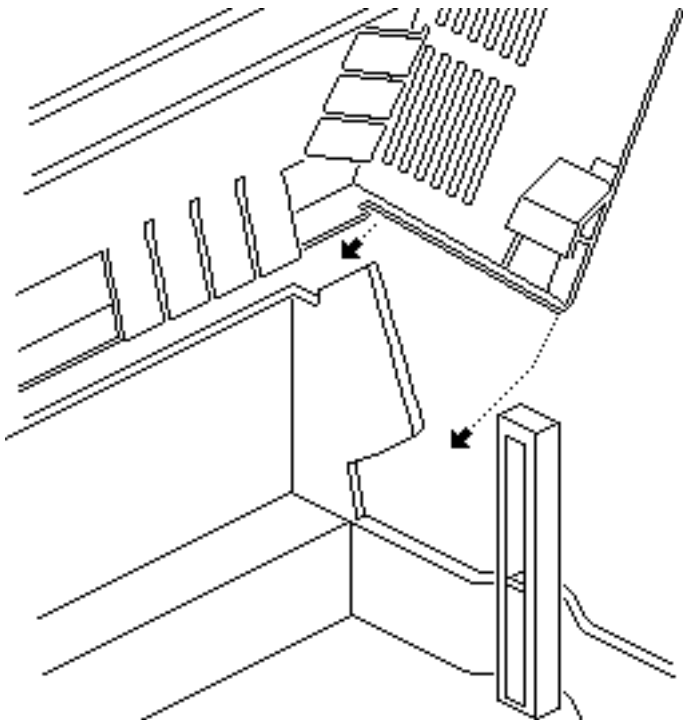

Replacement Note:
When replacing the cover, first place the notches at the back corners of the cover into notches at the raised corners of the base.





Release Mechanism

Before you begin, remove the cover.

Note: The following tools are required to disassemble the PowerBook Duo Dock:

- Small flat-blade screwdriver
- #2 crosstip screwdriver

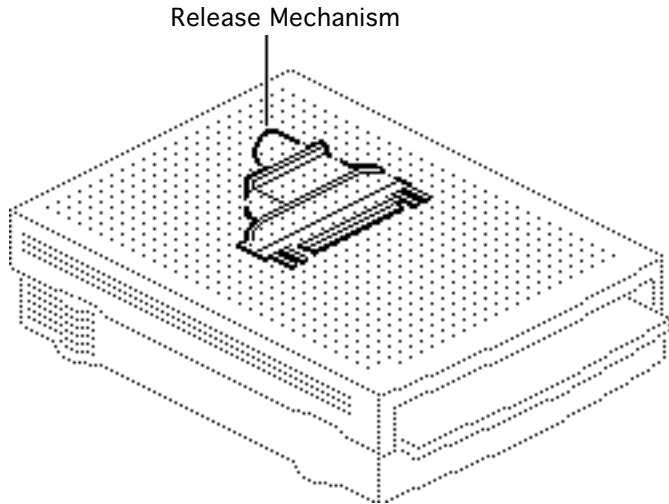



Caution: The PowerBook Duo Dock contains CMOS devices that are very susceptible to ESD damage. Review the ESD precautions in Bulletins/Safety.



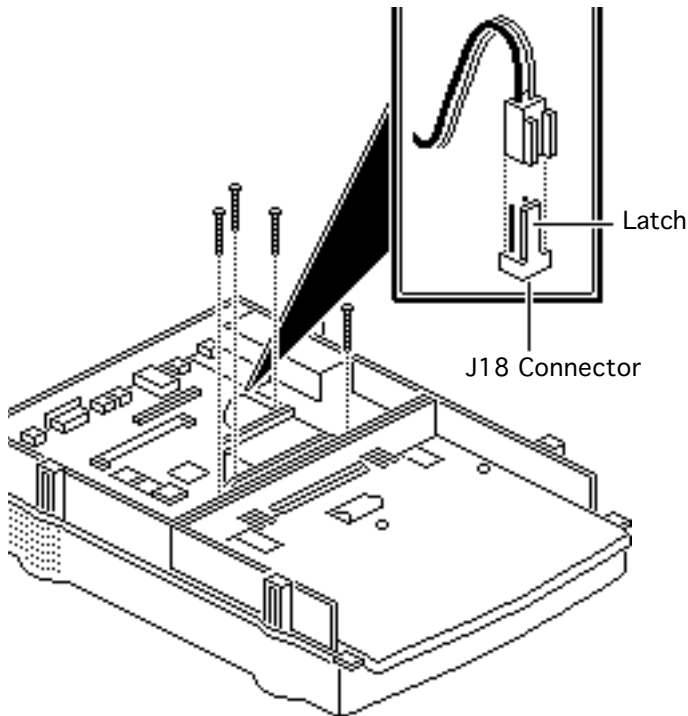

- 1 Using a small, flat-blade screwdriver, release the latch and disconnect the two-wire motor cable from connector J18.
- 2 Remove the four long screws that secure the release mechanism to the logic board.



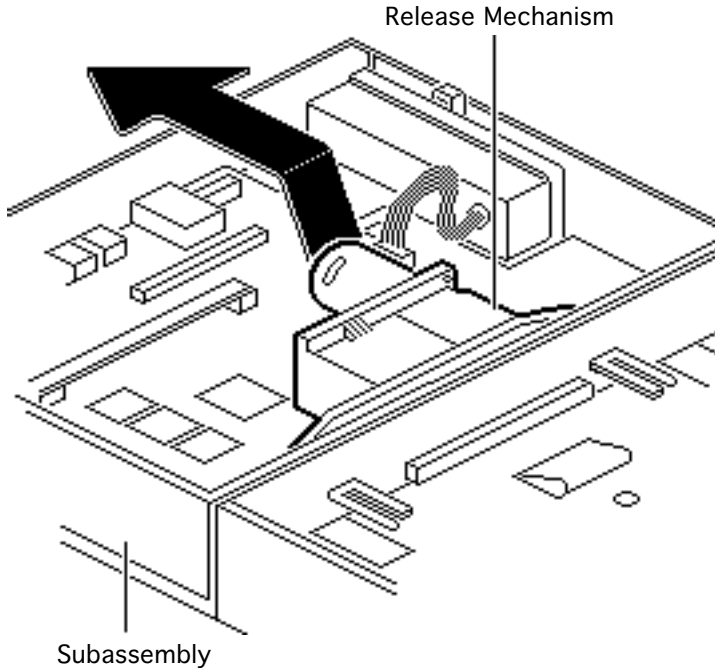

- 3 Raise the motor end of the release mechanism and pull the mechanism out of the subassembly.





Subassembly

Before you begin, remove the following:

- Cover
- Release mechanism

Caution: The PowerBook Duo Dock contains CMOS devices that are very susceptible to ESD damage. Review the ESD precautions in Bulletins/Safety.

- 1 Release the latch and disconnect the power supply cable from connector J11.

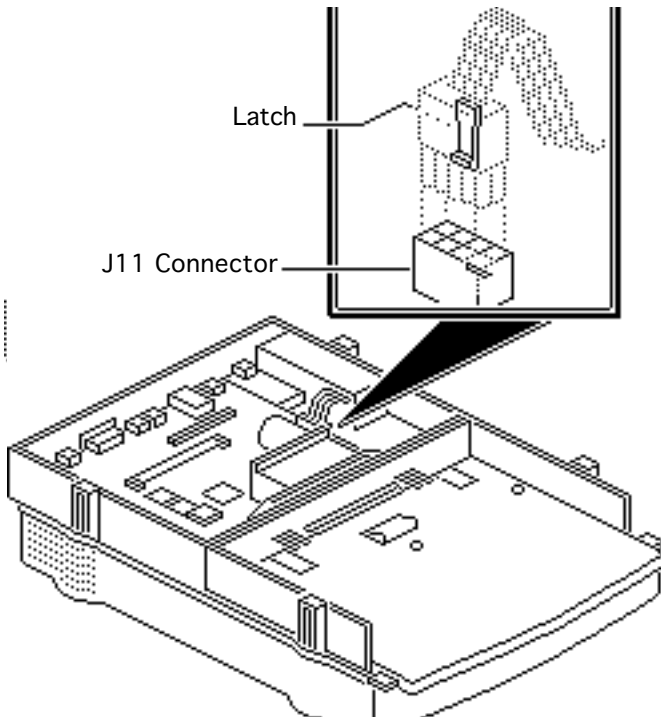

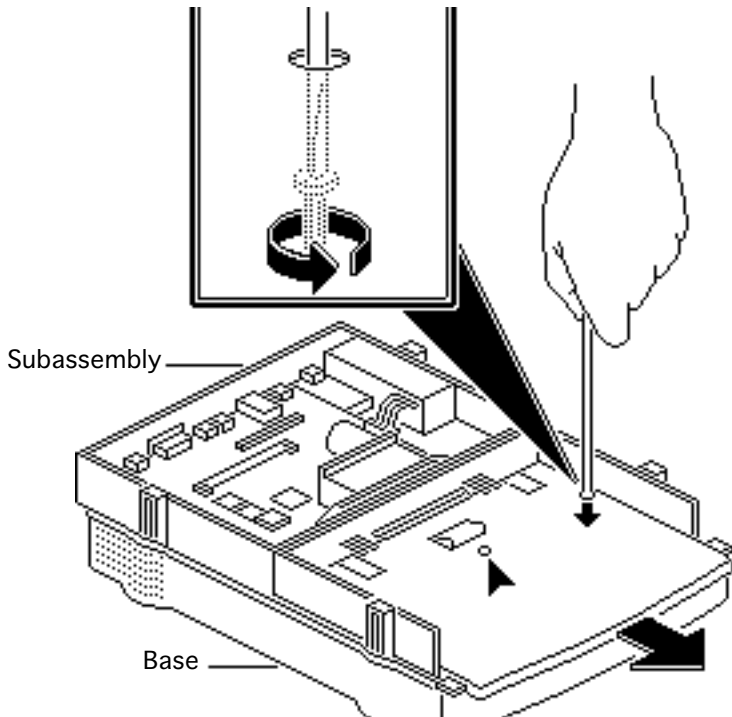

- 2 Using a small flat-blade screwdriver, loosen the two captive screws that secure the subassembly to the base.
- 3 **Note:** If you can't pull back the subassembly, further loosen the two captive screws that secure the subassembly to the base.

Pull the subassembly back slightly until it stops.



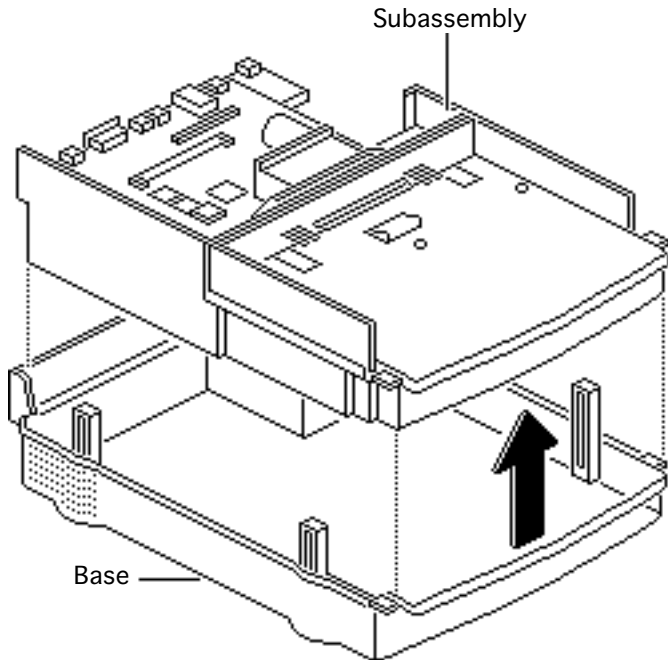

- 4 Clear room on the workbench pad beside the base.
- 5 Lift the subassembly straight up and remove it from the base. Place the subassembly beside the base.





Note: If you are replacing a damaged subassembly, first remove the logic board, floppy drive, hard drive (if installed), ejector, and speaker from the subassembly. Refer to the take-apart procedures that follow.





Logic Board

Before you begin, remove the following:

- Cover
- Release mechanism
- Subassembly
- Modem interface card (if installed)

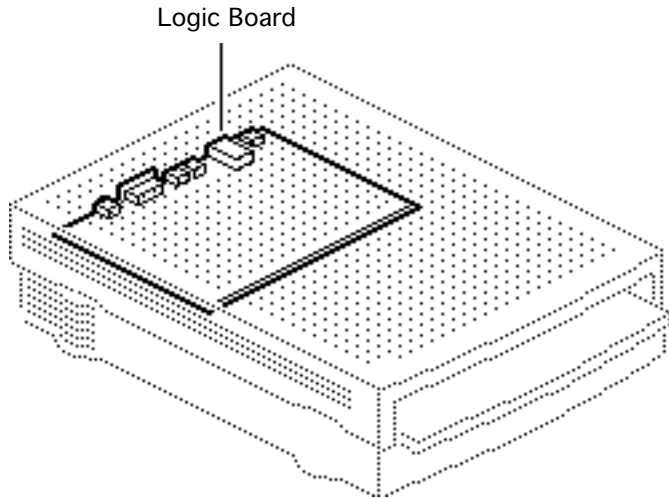



Caution: The PowerBook Duo Dock contains CMOS devices that are very susceptible to ESD damage. Review the ESD precautions in Bulletins/Safety.



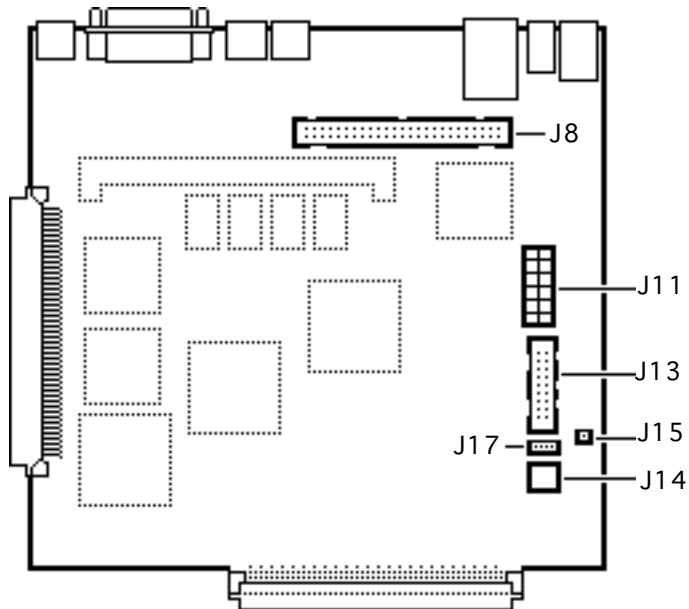

- 1 If installed, disconnect these cable connectors from the logic board:
 - Power supply cable from J11
 - Floppy drive cable from J13
 - Speaker cable from J15
 - Hard drive power cable from J14
 - Eject mechanism cable from J17
 - Hard drive data cable from J8





Note: You must first release latches on the power supply, speaker, and eject mechanism cables to disconnect them from the logic board connectors.



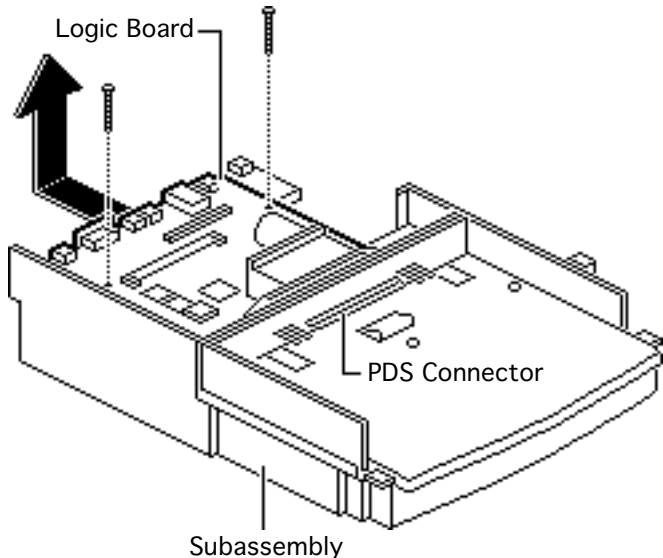

- 2 Remove the two remaining logic board mounting screws.
- 3 Raise the rear of the logic board and pull it out until the PDS connector clears the subassembly. Carefully lift the logic board with connected NuBus adapter straight out of the subassembly.



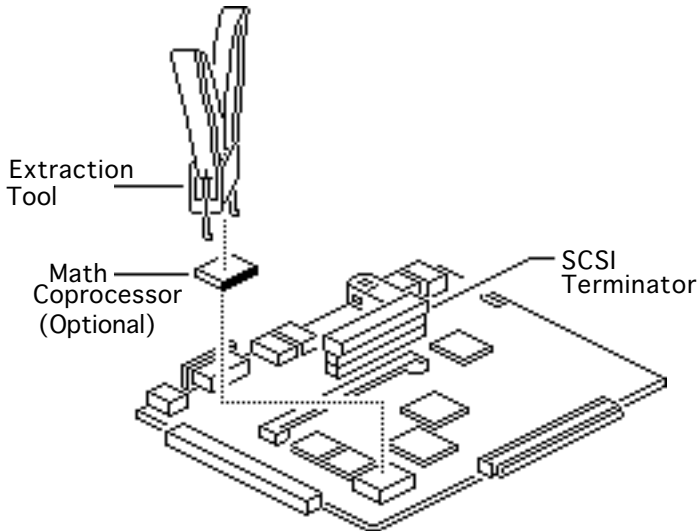

Note: If you are returning a defective logic board to Apple, be sure to disconnect the NuBus adapter card (see the next topic). Also remove the internal SCSI terminator, VRAM SIMM, math coprocessor, and modem interface card (if installed). Install these parts on the replacement logic board.





Note: To remove the optional math coprocessor from the original Duo Dock, use the VGC IC extraction tool (P/N 076-0264). Insert the tongs of the extraction tool into the slotted corners of the chip, and gently squeeze the handle.



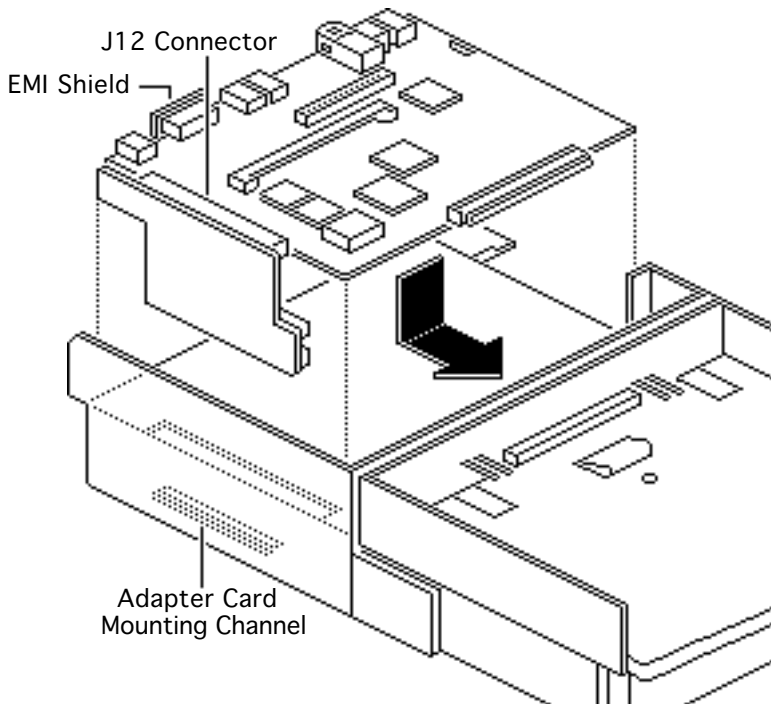

Replacement Note: When replacing the logic board, make sure the NuBus adapter card is properly connected to connector J12 and the bottom edge of the adapter card is in the mounting channel beneath the chassis.

Replacement Note: All Duo Dock logic boards should include an EMI shield over the video port. If necessary, install the EMI shield on the logic board. Extra EMI shields can be ordered from the Price Pages.





NuBus Adapter Card

Before you begin, remove the following:

- Cover
- Release mechanism
- Subassembly
- Modem interface card (if installed)
- Logic board

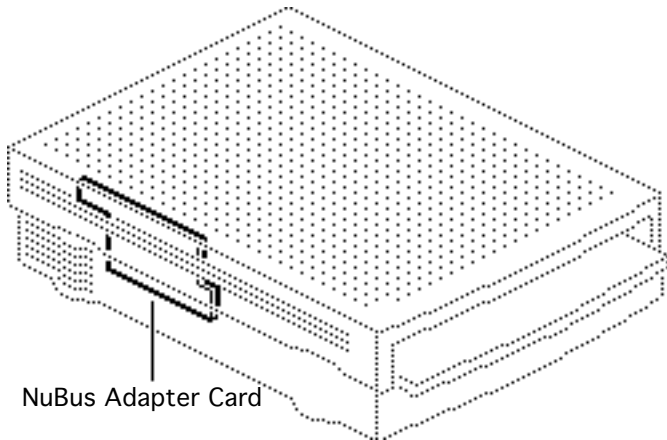



Caution: The PowerBook Duo Dock contains CMOS devices that are very susceptible to ESD damage. Review the ESD precautions in Bulletins/Safety.





Gently rock the NuBus adapter card from side to side and disconnect it from logic board connector J12.

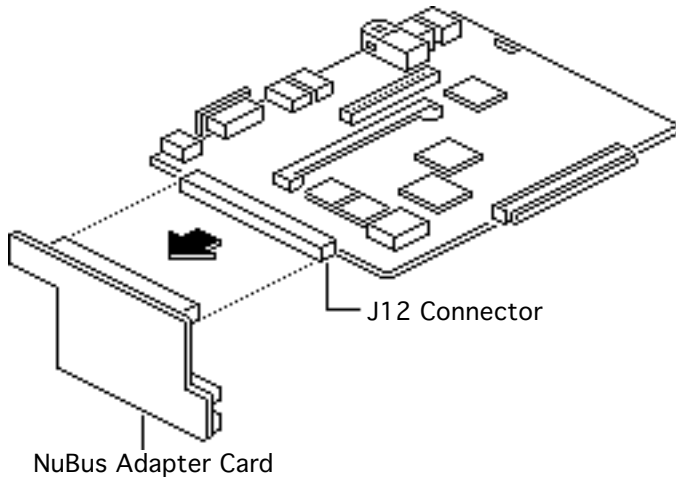



Floppy Drive

Before you begin, remove the following:

- Cover
- Release mechanism
- Subassembly

Caution: The PowerBook Duo Dock contains CMOS devices that are very susceptible to ESD damage. Review the ESD precautions in Bulletins/Safety.

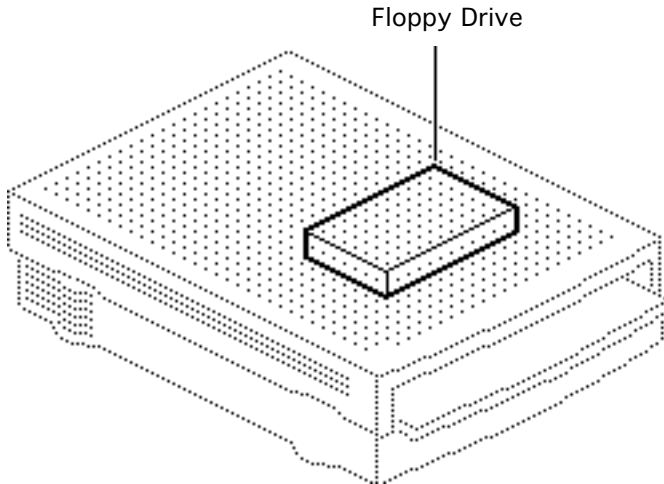

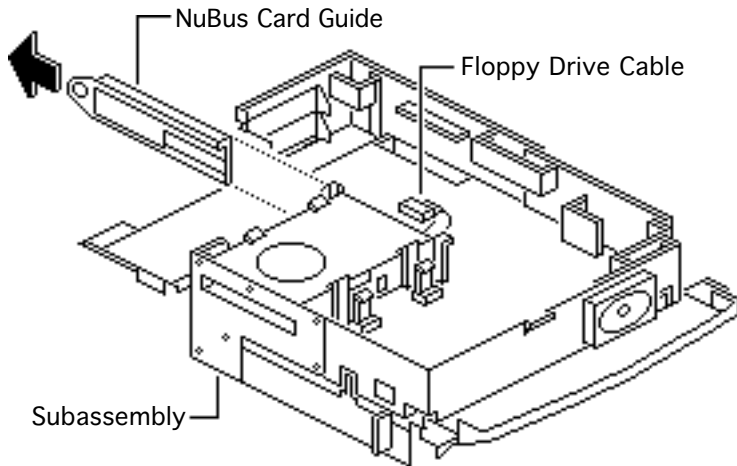

- 1 Turn over the subassembly and place it on the workbench pad with the floppy drive up.
- 2 Pull out the plastic NuBus adapter card guide.
- 3 Disconnect the floppy drive cable connector.



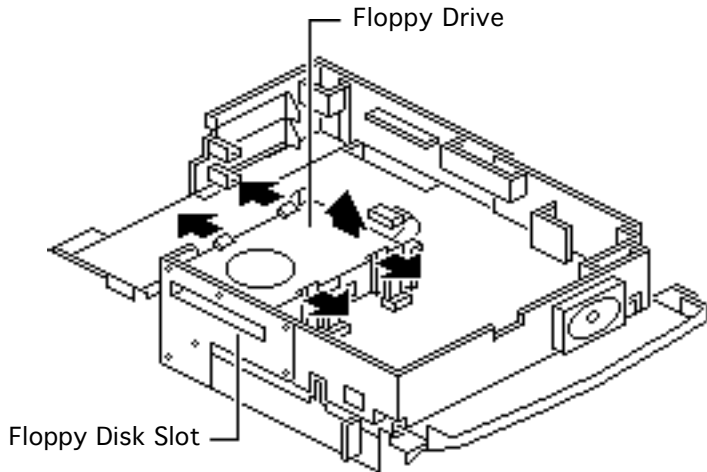

- 4 Pull out the two rear mounting latches and slightly lift the rear of the floppy drive.
- 5 Pull out the two front latches and remove the floppy drive from the subassembly.

Replacement Note:
When replacing the floppy drive in the subassembly mount, first lower the inject/eject mechanism into the floppy disk slot and then push the drive down until it latches.



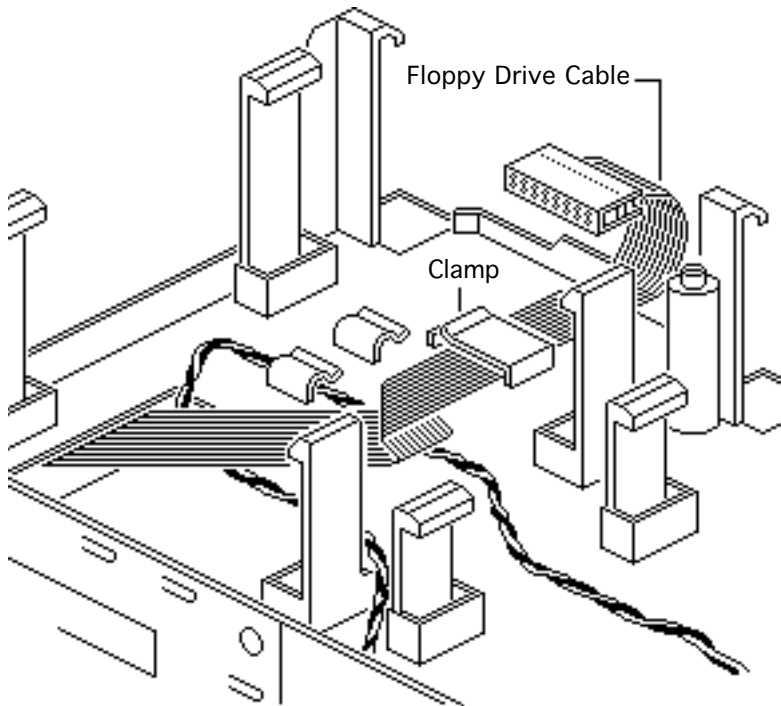

Note: If you need to replace a defective floppy drive cable, be sure to note how the cable is routed in the subassembly before removing the cable from the cable clamp.





Ejector

Before you begin, remove the following:

- Cover
- Release mechanism
- Subassembly
- Floppy drive

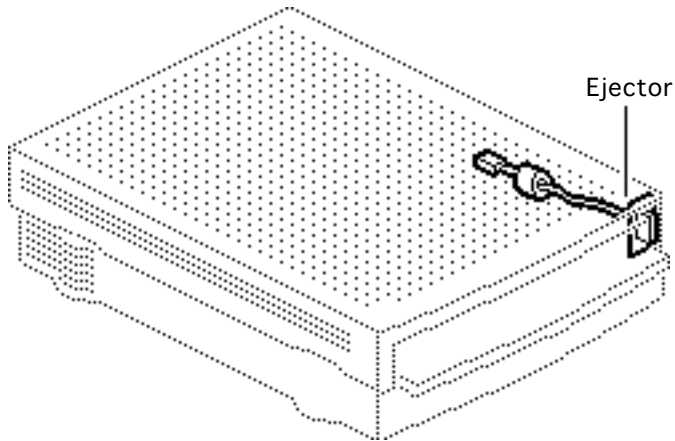

Caution: The PowerBook Duo Dock contains CMOS devices that are very susceptible to ESD damage. Review the ESD precautions in Bulletins/Safety.



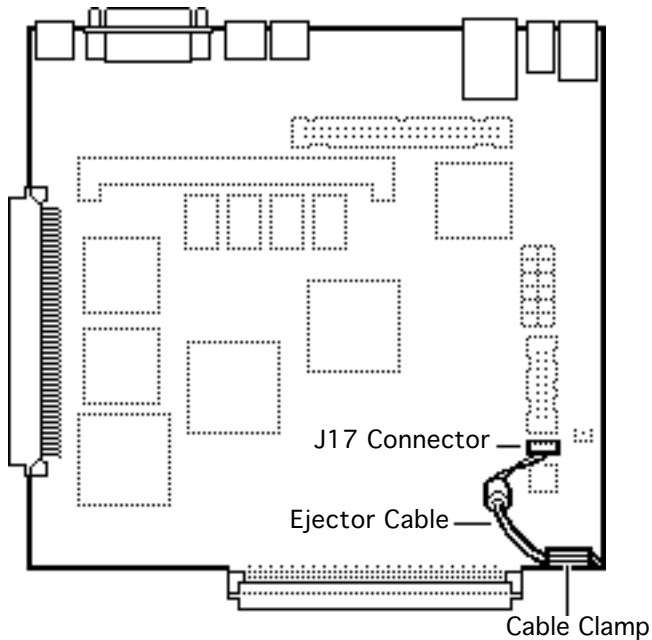

- 1 Release the latch and disconnect the ejector cable from connector J17.
- 2 Pry open the cable clamp and remove the ejector cable.



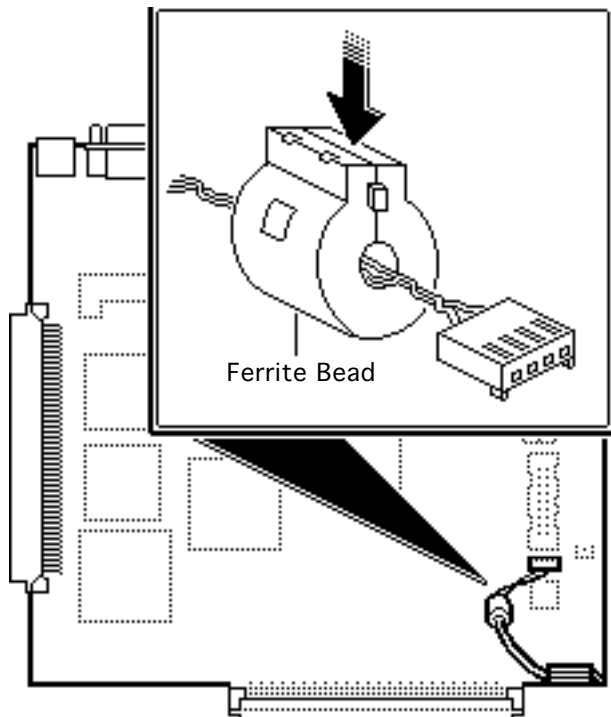

- 3 Push down on the flat surface of the ferrite bead and pull open the two halves of the bead. Remove the ferrite bead from the ejector cable.



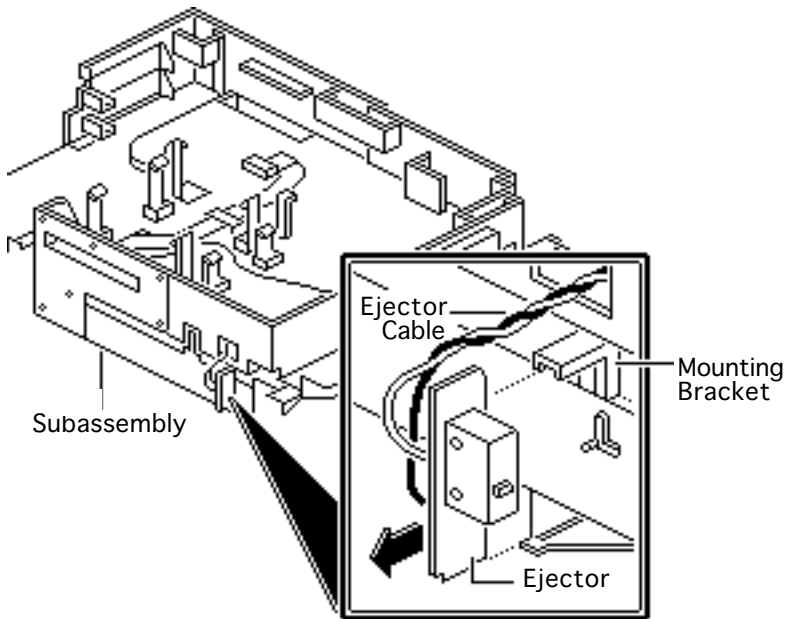

- 4 Turn over the subassembly and place it on the workbench pad.
- 5 Unlace the ejector cable from the subassembly. Remove the ejector from the mounting bracket on the outside edge of the subassembly.





Speaker

Before you begin, remove the following:

- Cover
- Release mechanism
- Subassembly
- Floppy drive

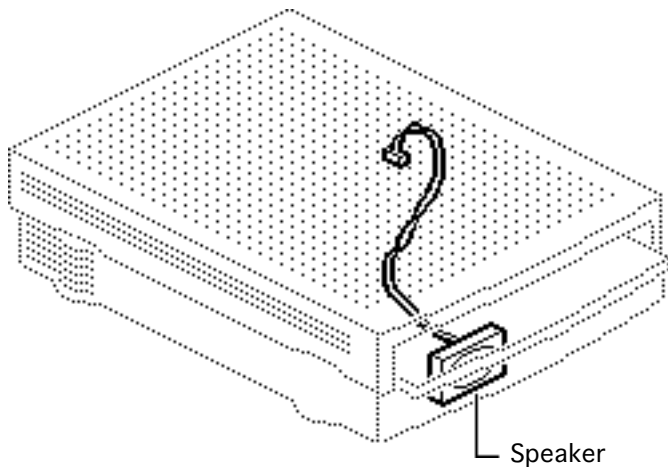

Caution: The PowerBook Duo Dock contains CMOS devices that are very susceptible to ESD damage. Review the ESD precautions in Bulletins/Safety.



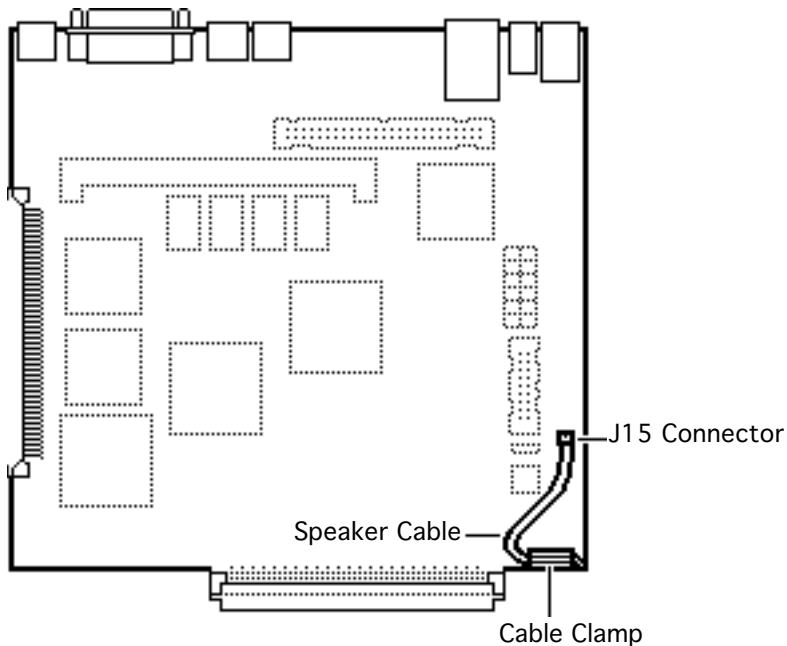

- 1 Release the latch and disconnect the speaker cable from connector J15.
- 2 Pry open the cable clamp and remove the speaker cable.



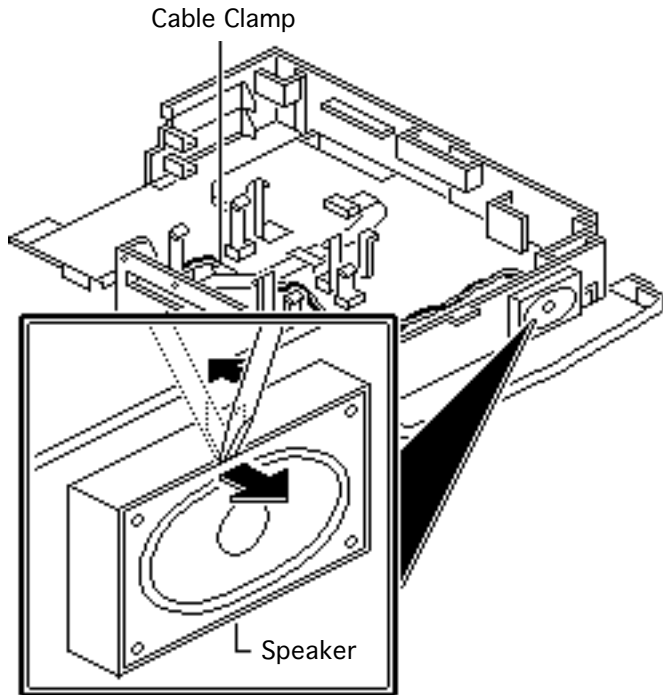

- 3 Turn over the subassembly and place it on the workbench pad.
- 4 Remove the speaker cable from the subassembly cable clamps.
- 5 Using a small flat-blade screwdriver, pry the speaker off the outside edge of the subassembly.





Power Supply

Before you begin, remove the following:

- Cover
- Release mechanism
- Subassembly

Caution: The PowerBook Duo Dock contains CMOS devices that are very susceptible to ESD damage. Review the ESD precautions in Bulletins/Safety.

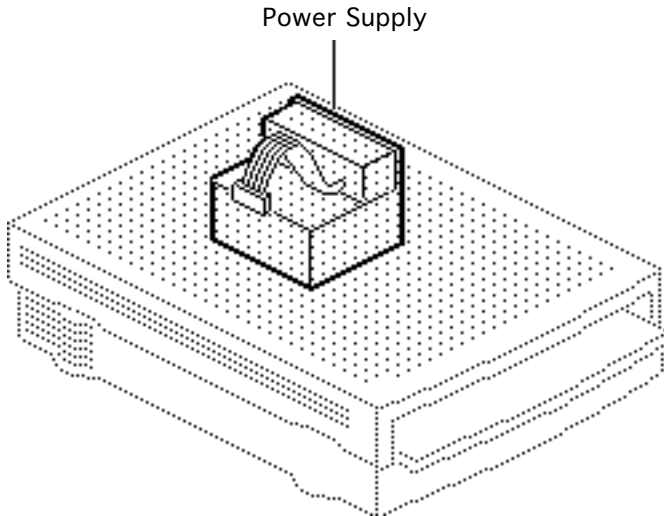

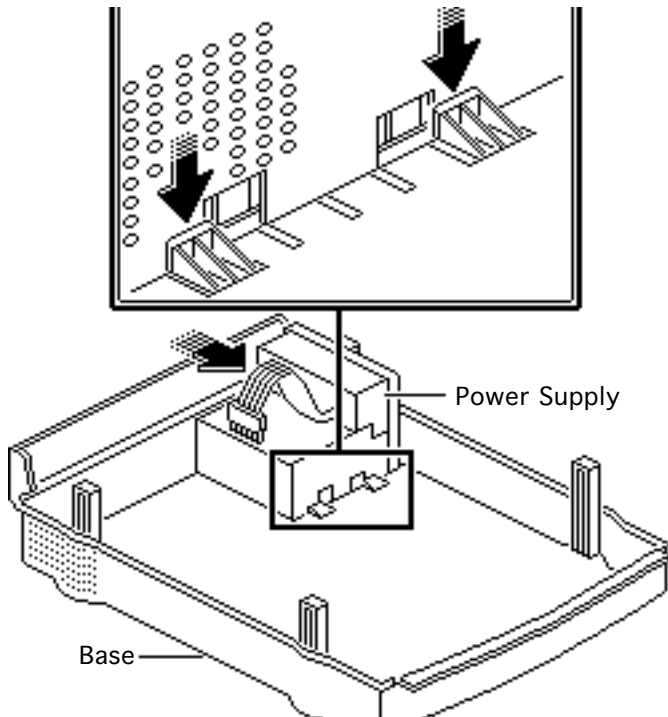

- 1 Depress the two plastic latches and push in the power supply at the receptacle.
- 2 Remove the power supply from the base.



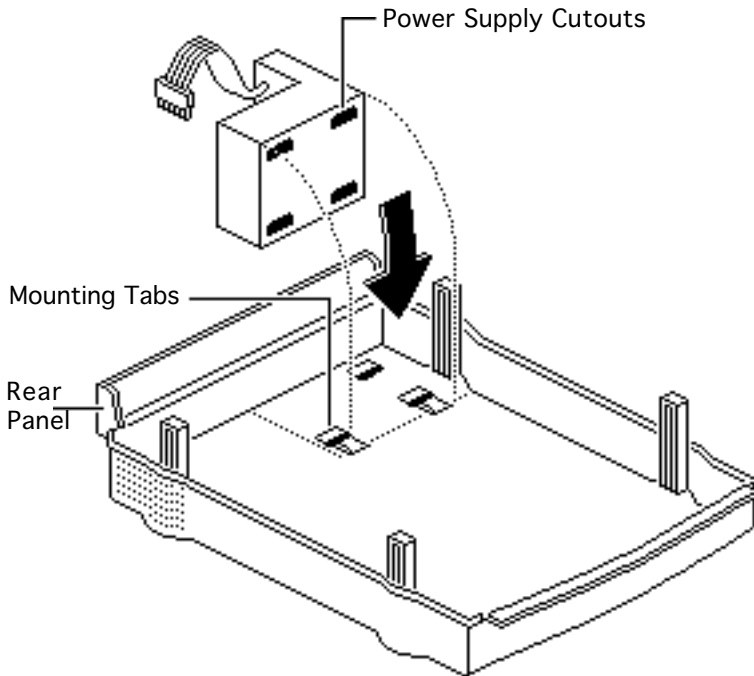

Replacement Note: When replacing the power supply, you must first hook the cutouts in the bottom of the power supply over the three mounting tabs in the base. Then firmly push the power supply toward the rear panel until the power supply latches into place.



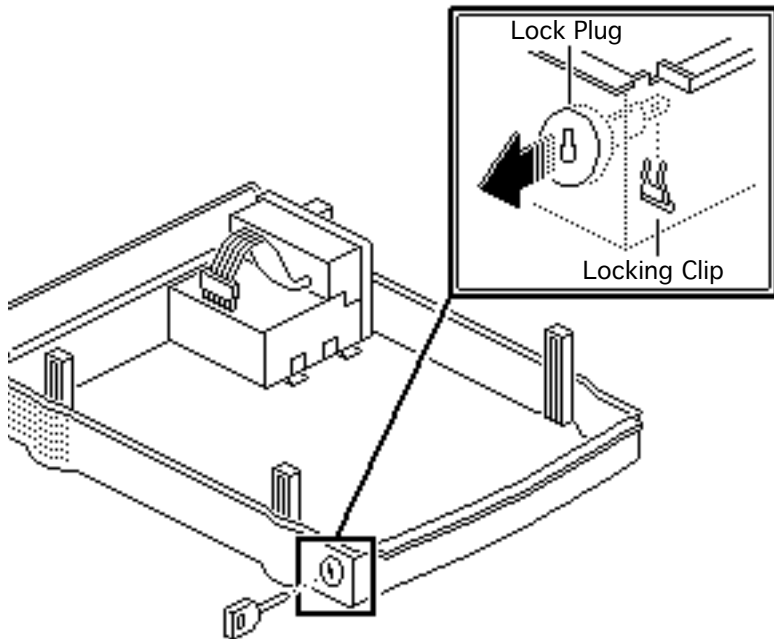

Lock Plug Assembly

Before you begin, remove the following:

- Cover
- Release mechanism
- Subassembly

Caution: The PowerBook Duo Dock contains CMOS devices that are very susceptible to ESD damage. Review the ESD precautions in Bulletins/Safety.

- 1 Pull the locking clip off the end of the lock plug.





- 2 Push the lock plug out of the base.





Base

To access the base, remove the following:

- Cover
- Release mechanism
- Subassembly
- Power supply

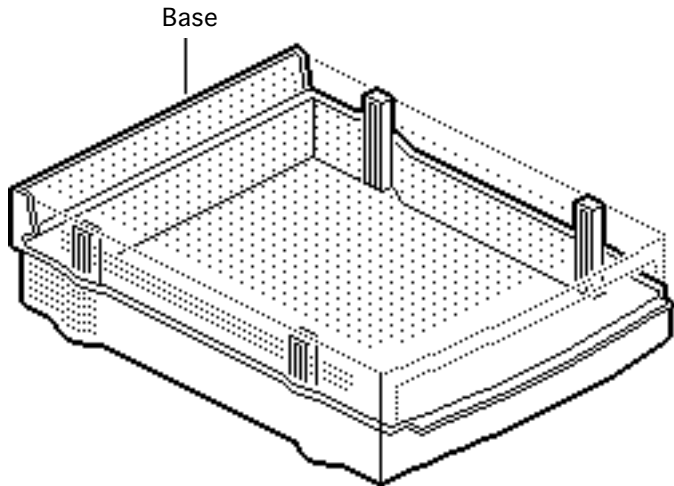



Upgrades

PowerBook Duo Dock





VRAM Upgrade

Before you begin, remove the cover.

Caution: The PowerBook Duo Dock contains CMOS devices that are very susceptible to ESD damage. Review the ESD precautions in Bulletins/Safety.

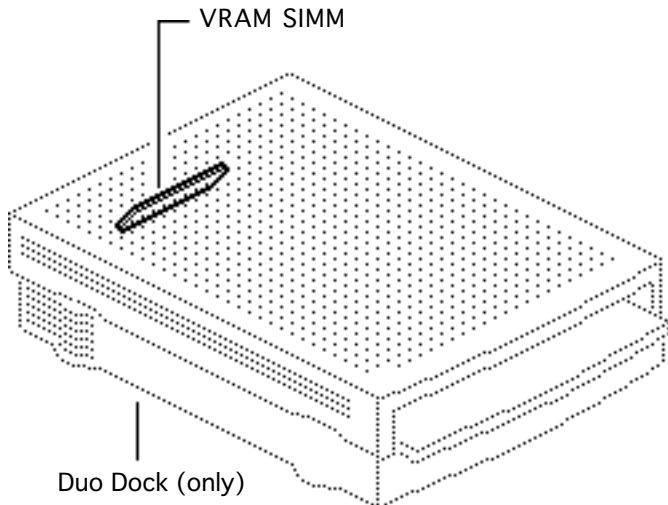



Note: The PowerBook Duo Dock has 512K of video RAM soldered on the logic board. You can increase the amount of VRAM to 1 MB by installing a 512K VRAM SIMM in the SIMM slot (connector J9). Use only 100 ns or faster VRAM SIMMs.

Note: You cannot increase the amount of video RAM on the Duo Dock II, which comes with 1 MB VRAM.



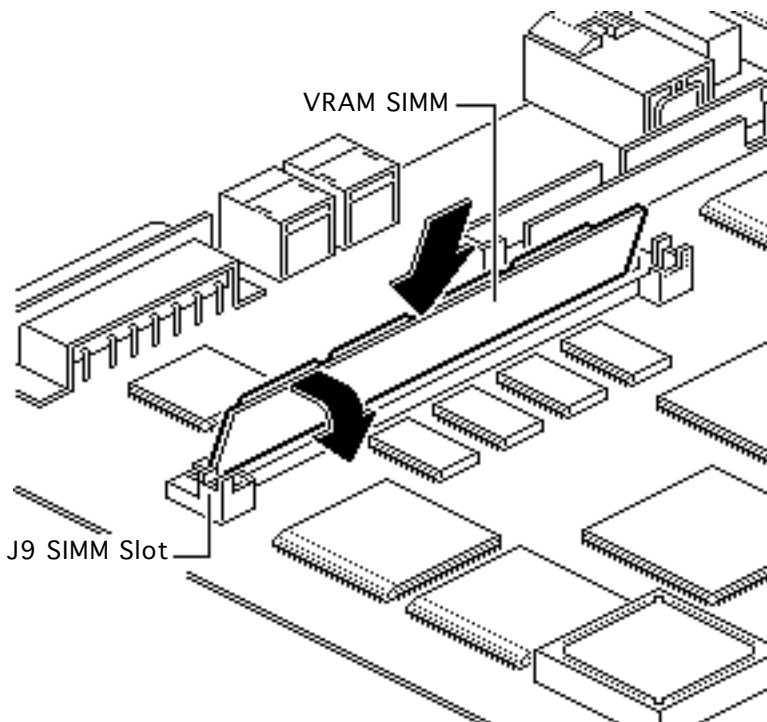

- 1 Grasp the VRAM SIMM by its edges with the contacts pointing down. Insert the SIMM at an angle into SIMM slot J9.
- 2 Push back on the SIMM until it snaps into place.





Math Coprocessor

Before you begin, remove the cover.

Caution: The PowerBook Duo Dock contains CMOS devices that are very susceptible to ESD damage. Review the ESD precautions in Bulletins/Safety.

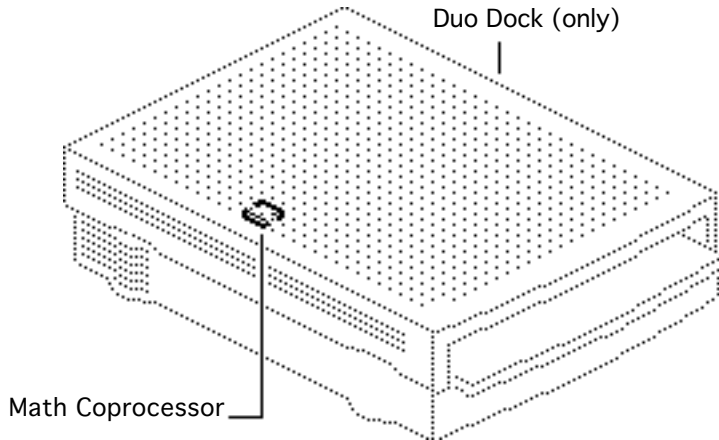



Note: You can add a Motorola 68882 math coprocessor to the logic board of the original Duo Dock, thereby increasing the overall performance of the Macintosh Duo System.

Note: The Duo Dock II includes a math coprocessor and therefore does not need this upgrade.



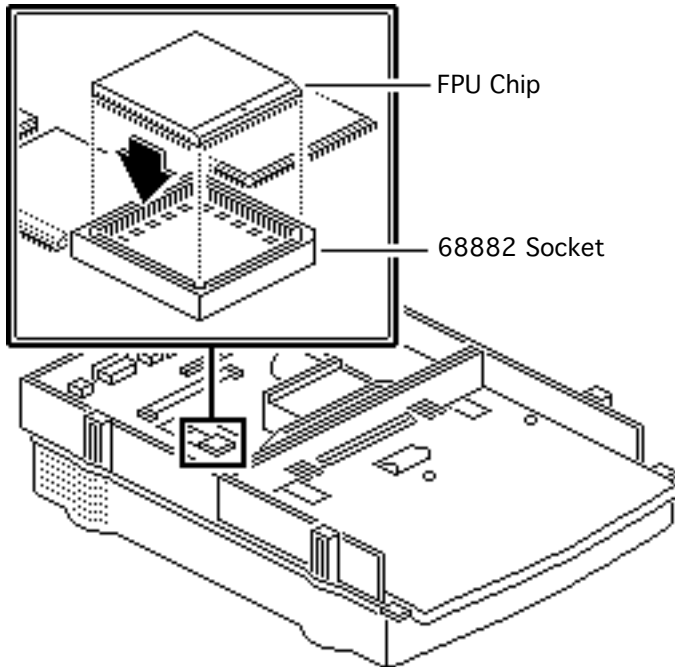

- 1 Position the math coprocessor with the beveled edge of the chip toward the front of the dock.
- 2 Align the pins in the socket and gently press the chip into the 68882 socket.





Modem Interface Card

Before you begin, remove the cover.

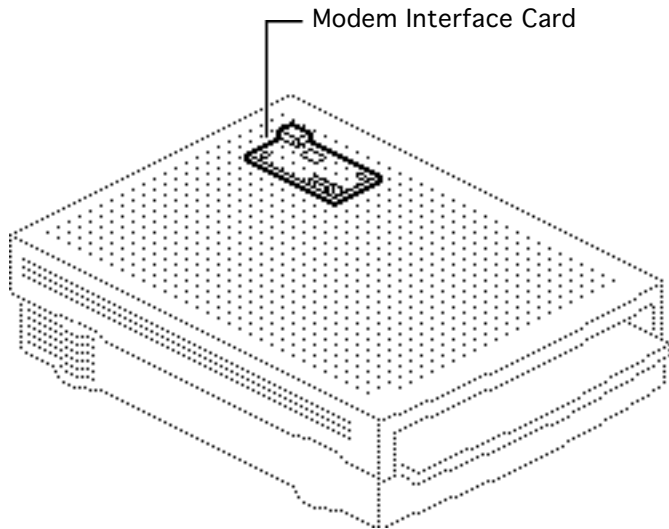

Note: The modem interface card provides telephone line interface (DAA) circuitry for a PowerBook Duo with an internal modem. To address the differences between telephone interfaces and specifications, Apple provides both domestic and international versions of the modem interface card.





Caution: The Duo Dock contains CMOS devices that are very susceptible to ESD damage. Review the ESD precautions in Bulletins/Safety.



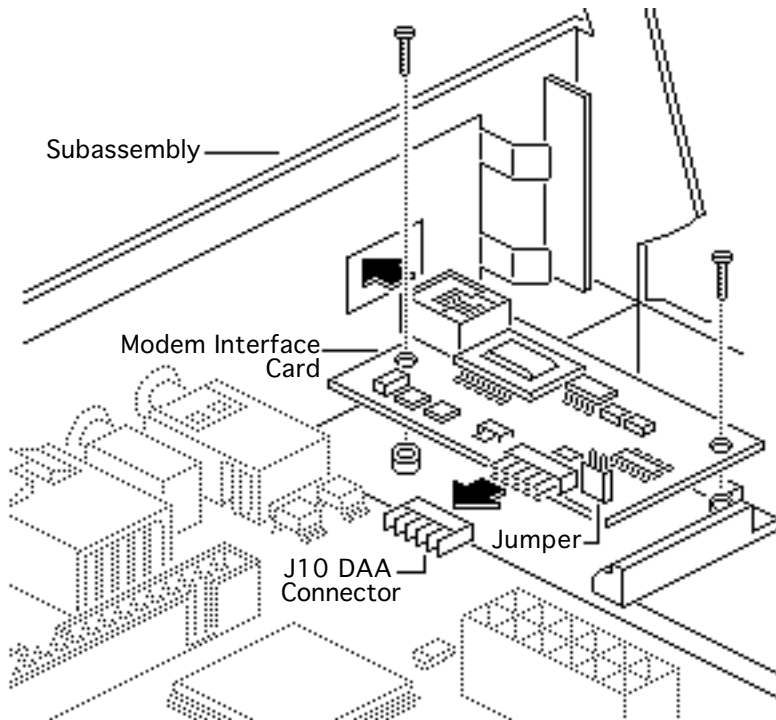

- 1 Remove the modem port cover from the subassembly.
- 2 Insert the modem interface card telephone jack into the modem port and position the modem interface card on the chassis. Using a small flat-blade screwdriver, press the modem connector onto DAA connector J10.
- 3 Install the two modem card mounting screws.





Important: In Japan only, install a jumper on modem interface connector J3. A jumper is included with every modem interface card.





Hard Drive Upgrade

Before you begin, remove the following:

- Cover
- Release mechanism
- Subassembly
- Floppy drive

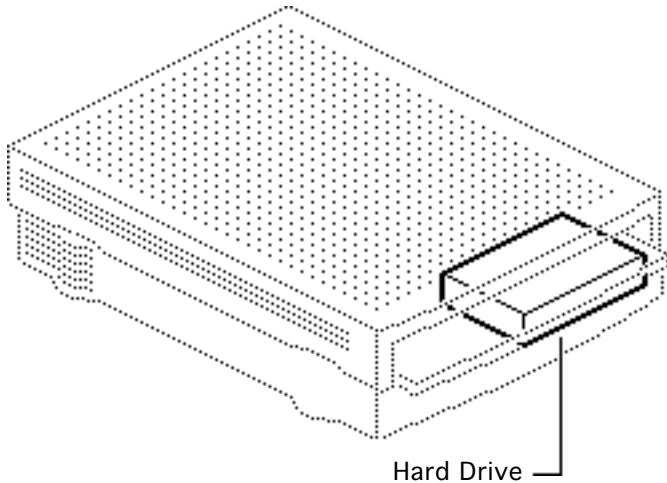



Caution: The PowerBook Duo Dock contains CMOS devices that are very susceptible to ESD damage. Review the ESD precautions in Bulletins/Safety.

Note: Any 3.5-inch, 1-inch-high hard drive can be installed in the hard drive bay in the Duo Dock.



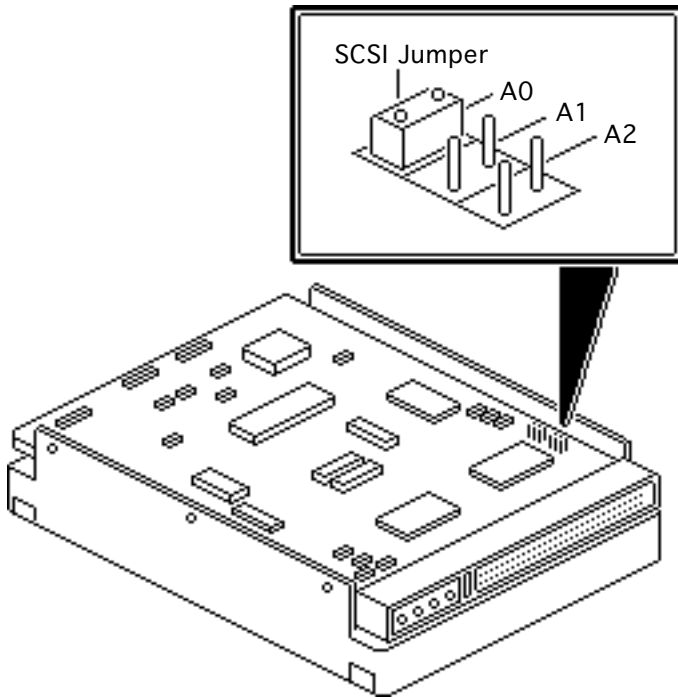

Important: The 230 MB drive ships with a SCSI ID of 0 (no jumpers are on the SCSI select pins). When you install the 230 MB drive in the Duo Dock, you must place a jumper on the drive's SCSI select pins at location A0. The jumper creates a SCSI ID of 1.



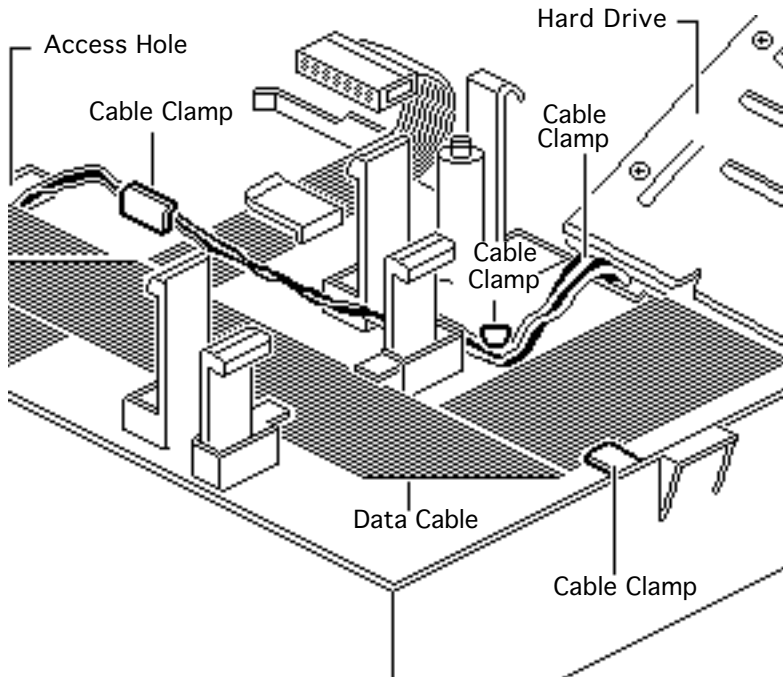

- 1 Turn over the subassembly and place it on the workbench pad.
- 2 Position the hard drive in the subassembly as shown.
- 3 Route the hard drive data cable and the hard drive power cable beneath the floppy drive bay and through the chassis access hole. Hook the cables beneath the cable clamps as shown.



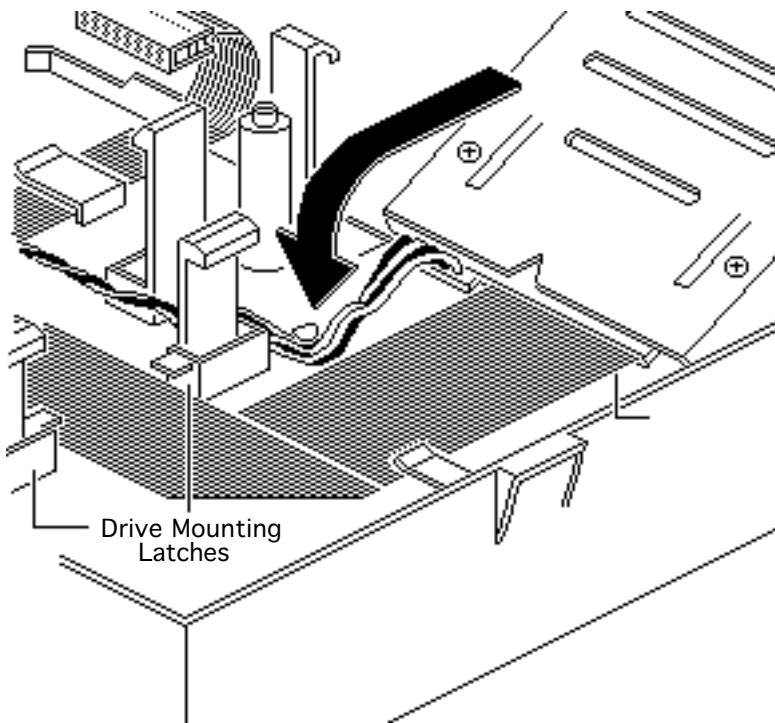

- 4 Lower the hard drive and push down on the drive until it snaps beneath the mounting latches.





- 5 Remove the SCSI terminator from connector J8.
- 6 Connect the hard drive data cable to connector J8 and the hard drive power cable to connector J14.

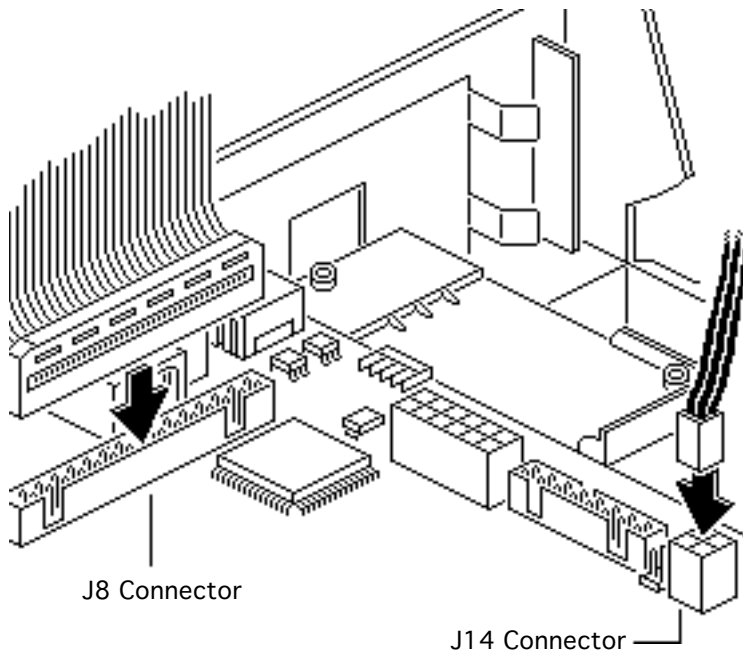



NuBus Expansion Cards

Before you begin, remove the following:

- Cover
- Release mechanism
- Subassembly

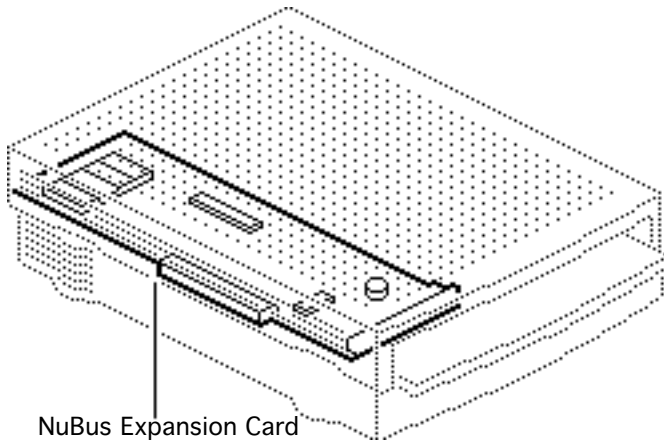



Caution: The PowerBook Duo Dock contains CMOS devices that are very susceptible to ESD damage. Review the ESD precautions in Bulletins/Safety.

Note: Install this card only on the original Duo Dock; it is unnecessary on the Duo Dock II, which already supports Ethernet.



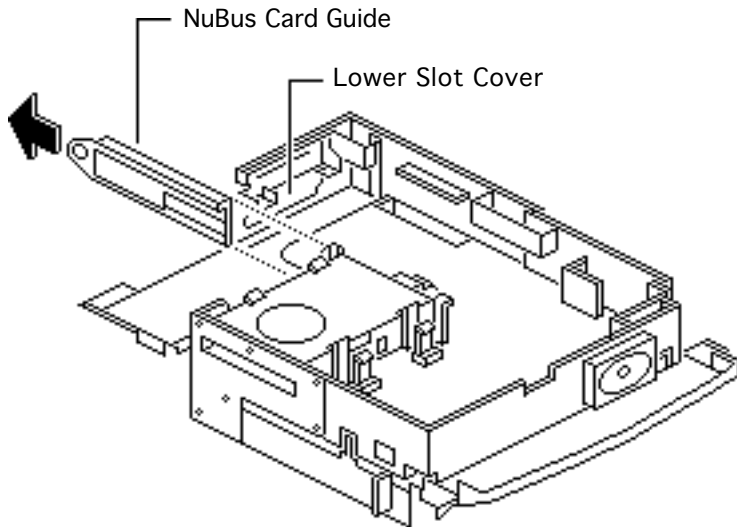

- 1 Turn over the subassembly and place it on the workbench pad.
- 2 Pull out the plastic NuBus card guide.
- 3 Remove the lower NuBus slot cover from the subassembly.



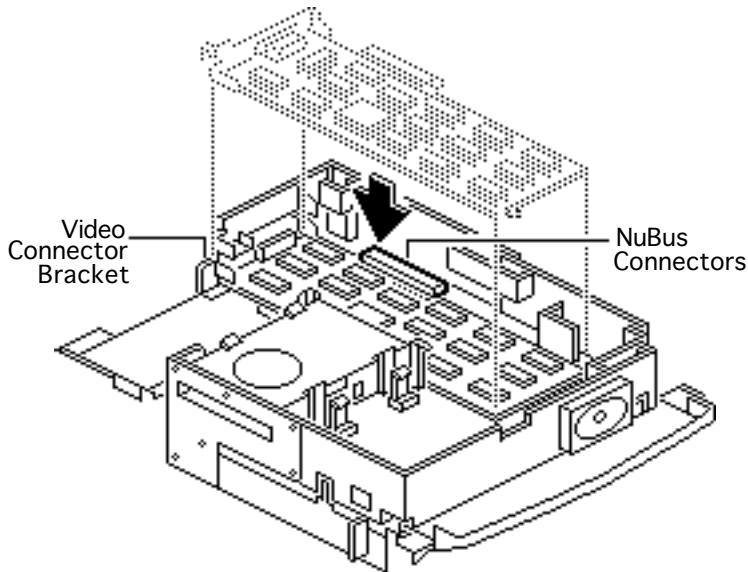

Note: Install the first NuBus card in the lower slot (which is the upper slot when the dock is upright). That way you won't have to remove this card if you install a second NuBus card later.

- 4 Position the NuBus card in the lower slot and hook the video connector bracket onto the chassis.
- 5 Press together the NuBus connectors.



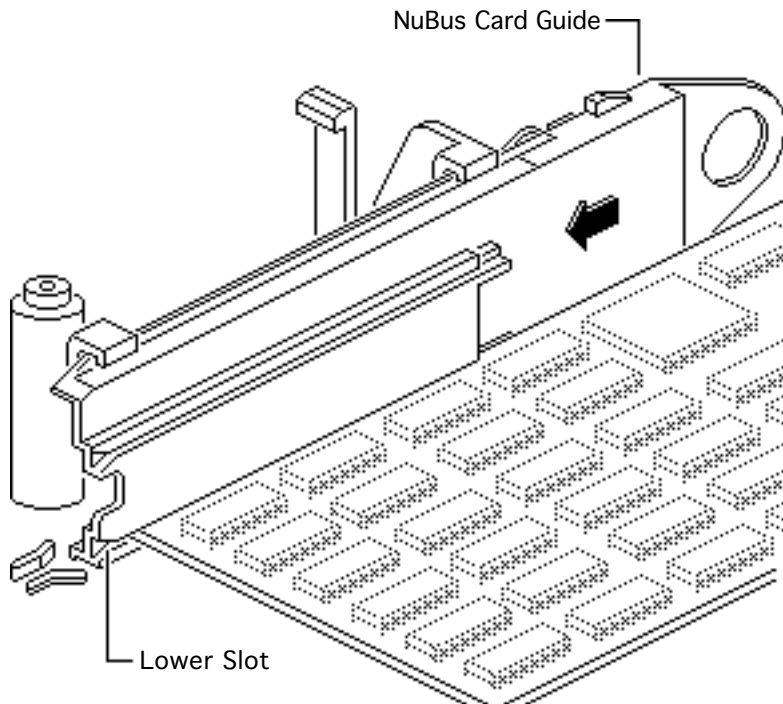

- 6 Align the lower slot in the NuBus card guide with the edge of the NuBus card. Replace the card guide on the subassembly.





Duo Dock II Upgrade

Before you begin, remove the following:

- Cover
- Release mechanism
- Subassembly
- Modem interface card (if installed)

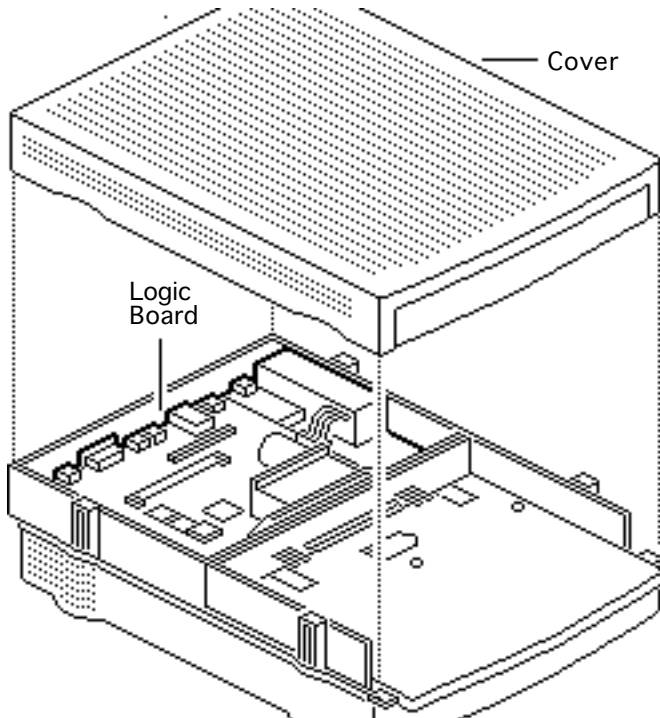



Caution: The Macintosh Duo Dock contains CMOS devices that are very susceptible to ESD damage. Review the ESD precautions in Bulletins/ Safety.

Note: Upgrade the Duo Dock to a Duo Dock II by adding a new logic board and cover. These parts are available individually, not as a kit.





- 1 Install the Duo Dock II logic board and cover (see “Logic Board” and “Cover”).





Exploded View

PowerBook Duo Dock





PowerBook Duo Dock Exploded View

