



Apple Two-Page Mono Monitor





Basics

Two-Page Monochrome Monitor





Monitor Distortion

Overview

All large-screen monitors are susceptible to distortions caused by environmental conditions. These distortions are usually not visible on monitors with smaller screens.

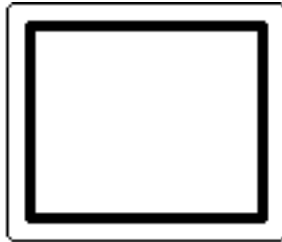

Ideal Raster

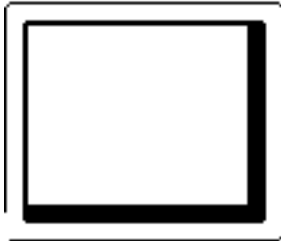

Raster Shifted Up
and Left

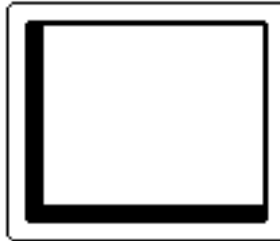

Raster Shifted Right





Important: Even monitors set to factory specifications may appear distorted when set up in a new environment.

Common environmentally-caused distortions are shown on this and the following cards. Always check first for environmental causes before attempting to repair or adjust a monitor with a distorted raster.



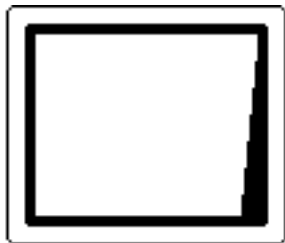

Right Edge Not Straight

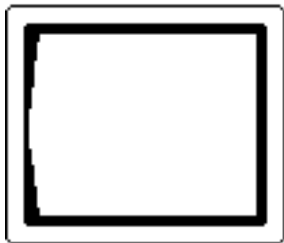

Left Side Bowed Out



Right Side Bowed In

Environmental Influences

The following environmental conditions may distort the raster of a Two-Page Monochrome Monitor:

- Proximity to metal objects, such as metal desks, file cabinets, and bookshelves. Metal objects affect the earth's magnetic field. Earth magnetism usually distorts only the edges of the screen.





- Fluorescent lights, other monitors, or electronic appliances such as coffee makers and copy machines. These objects cause dynamic raster distortion, that is, movement or jitter of the image.





Troubleshooting

Important: Module swapping cannot fix a monitor with environmental distortion problems, and adjusting a monitor with such problems alters the factory settings.

Note: If the monitor has shifted up/down or right/left only, adjust it using the centering controls. If you then move the monitor, you may need to readjust the centering controls.

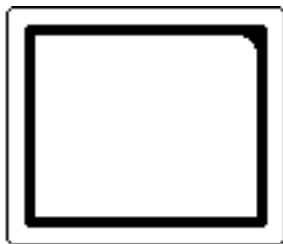

Upper-Right Corner Rounded

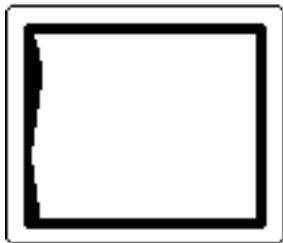

Left Edge S-Shaped



Raster Tilted Right





Before adjusting a monitor with a distorted raster, try the following:

- Swivel or move the monitor, or
- Remove the monitor from the building and recheck it in another location.

If the display changes (for better or worse) when you move it to another location, the environment is the source of the problem. Relocate the monitor or remove the distortion-causing object.





If the display does not change when you move the monitor to another location, continue troubleshooting the problem (refer to Troubleshooting/Symptom Charts).





Specifications

Apple Two-Page Monochrome
Monitor





Characteristics

Picture Tube

21-in. diagonal screen (20-in. viewable image)
Phosphor EIA Type P4 (white)
Flat, square, high-contrast, antiglare surface

Screen Resolution

1,152 x 870 lines; 77 dpi
Displays up to 16 grays with 512K of video RAM

Scan Rates

Vertical refresh rate: 75 Hz
Horizontal scan rate: 68.7 kHz
Dot clock: 100 MHz





**Active Video
Display Area**

15 in. by 11.3 in.
(381 mm by 287 mm)

Input Signal

Video: analog; RS-343 standard





Controls

User Controls

Rear panel: power switch

Right side: brightness and contrast controls





Physical and Electrical

Power Supply

Universal power supply

Voltage: 90–270 VAC, self-configuring

Frequency: 47–63 Hz

Power: 95 W maximum

Size and Weight

Height: 15.7 in. (399 mm)—add 3.2 in. (81 mm) for integrated stand

Width: 19.5 in. (495 mm)

Depth: 17.4 in. (442 mm)

Weight: 55 lb. (25 kg)

Monitor Stand

Integrated, tilt-and-swivel stand





Operating Environment

Temperature

50°F–95°F (10°C–35°C)

Humidity

90% maximum, noncondensing

Altitude

10,000 ft. (3,048 m) maximum





Troubleshooting

Apple Two-Page Monochrome Monitor





General

The Symptom Charts included in this chapter will help you diagnose specific symptoms related to your product. Because cures are listed on the charts in the order of most likely solution, try the first cure first. Verify whether or not the product continues to exhibit the symptom. If the symptom persists, try the next cure. (Note: If you have replaced a module, reinstall the original module before you proceed to the next cure.)

If you are not sure what the problem is, or if the Symptom Charts do not resolve the problem, refer to the Flowchart for the product family.

For additional assistance, contact Apple Technical Support.





Symptom Charts

No Raster

No raster, LED off

- 1 Check AC power cord connections.
- 2 Check internal power connectors.
- 3 Replace blown fuse.
- 4 Replace power supply.
- 5 Replace on/off switch filter assembly.
- 6 Replace deflection board.

No raster, LED on

- 1 Adjust brightness and contrast knobs.
- 2 Verify that video card in computer is working properly.
- 3 Check power supply and deflection board connections.
- 4 Check CRT socket connectors.
- 5 Replace video board.
- 6 Replace deflection board.
- 7 Replace CRT and yoke assembly.





Geometry

Raster size too short, tall, narrow, or wide	<ol style="list-style-type: none">1 Adjust horizontal-size and vertical-size controls.2 Replace deflection board.3 Replace CRT and yoke assembly.
Raster not centered	<ol style="list-style-type: none">1 Verify that distortion is not due to environmental conditions. Move monitor to another location.2 Adjust horizontal-shift and vertical-shift controls.3 Replace video board.
Bad vertical linearity	<ol style="list-style-type: none">1 Adjust vertical linearity control.2 Replace deflection board.
Bad horizontal linearity	<ol style="list-style-type: none">1 Adjust horizontal linearity control.2 Replace deflection board.





Synchronization

Single horizontal or vertical line appears on screen

- 1 Check yoke connectors.
- 2 Check CRT socket connectors.
- 3 Replace deflection board.
- 4 Replace CRT and yoke assembly.

Picture breaks into diagonal lines

- 1 Connect another monitor to computer. Switch on monitor to verify that computer produces video signal.
- 2 Check connections between video board and deflection board.
- 3 Replace deflection board.
- 4 Replace video board.

Picture rolls vertically

- 1 Verify that video card in computer is working properly.
- 2 Check connections between video board and deflection board.
- 3 Replace deflection board.
- 4 Replace video board.





Video

Picture is too dark or too bright

- 1 Adjust contrast and brightness knobs.
- 2 Verify that video card in computer is working properly.
- 3 Check connection between contrast/brightness assembly and video board.
- 4 Perform video adjustments.
- 5 Replace video board.
- 6 Replace contrast/brightness assembly.
- 7 Replace CRT and yoke assembly.

Contrast/brightness unadjustable

- 1 Check connection between contrast/brightness assembly and video board.
- 2 Replace contrast/brightness assembly.
- 3 Replace video board.
- 4 Replace deflection board.
- 5 Replace CRT and yoke assembly.





(Continued)

Out of focus

- 1 Check CRT socket connectors.
- 2 Check connections between video board and deflection board.
- 3 Perform focus adjustment.
- 4 Check screen brightness with a light meter. If reading is “10” or higher, perform the cutoff and screen luminance adjustments.
- 5 Replace video board.
- 6 Replace deflection board.
- 7 Replace CRT and yoke assembly.





Miscellaneous

Picture jitters or flashes

- 1 Check all grounding cable connections.
- 2 Confirm that adjacent computer equipment is properly grounded. Move electrical devices away from the monitor and temporarily shut off all fluorescent lights.
- 3 Check connections between video board and deflection board.
- 4 Replace deflection board.

At a resolution of 1152x870, jitter or a wavy image appears on right side, left side, or entire screen

Note: This symptom occurs with Power Macintosh 9600 computers using an Apple/IMS video card with any display set at 1152x870 screen resolution. The computer and the display are working properly. However, video cards with serial numbers lower than Fx705xxx should be replaced. Apple's service stock has been inspected and upgraded, so replacement video boards should not exhibit this symptom.

Check the serial number on the video card. If it is lower than Fx705xxx, replace the video card with a new one (Apple service part number 661-1409).

Black spots on screen (burnt phosphors)

Replace CRT.





Monitor Stand

Monitor stand does not swivel

- 1 Verify that “Front” indicator on tilt/swivel mechanism aligns with “Front” indicator on base of monitor stand.
- 2 Verify that snap lock assembly on bottom of monitor stand is in place.

Monitor stand does not tilt

- 1 Verify that plastic plug is in snap lock assembly.
- 2 Verify that snap lock assembly on bottom of monitor stand is in place.





Take Apart

Apple Two-Page Monochrome
Monitor





Swivel Stand

No preliminary steps are required before you begin this procedure.

Note: Remove the tilt-swivel stand before you remove the CRT.

- 1 Tilt the monitor onto its left side.
- 2 Slide the monitor stand forward toward the bezel.

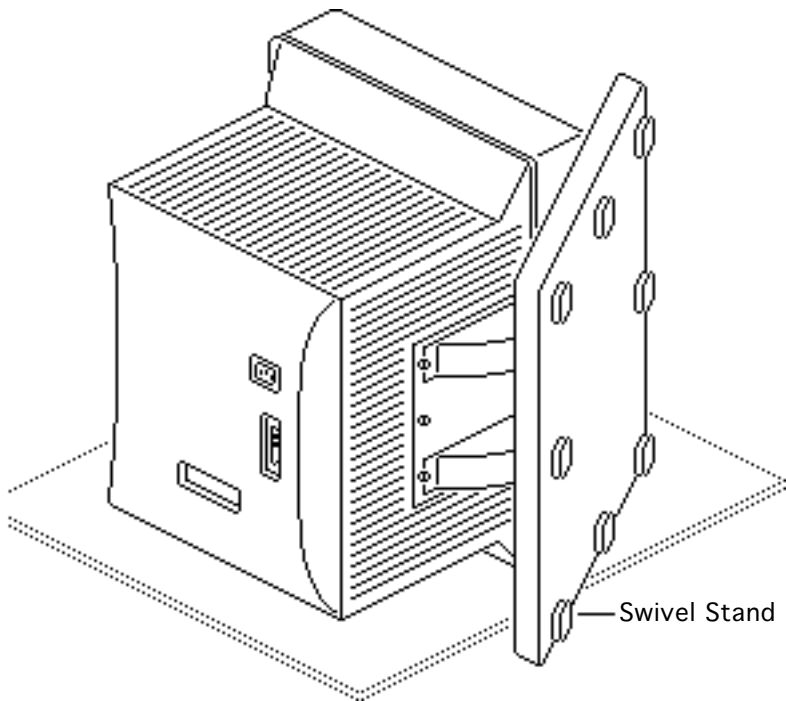

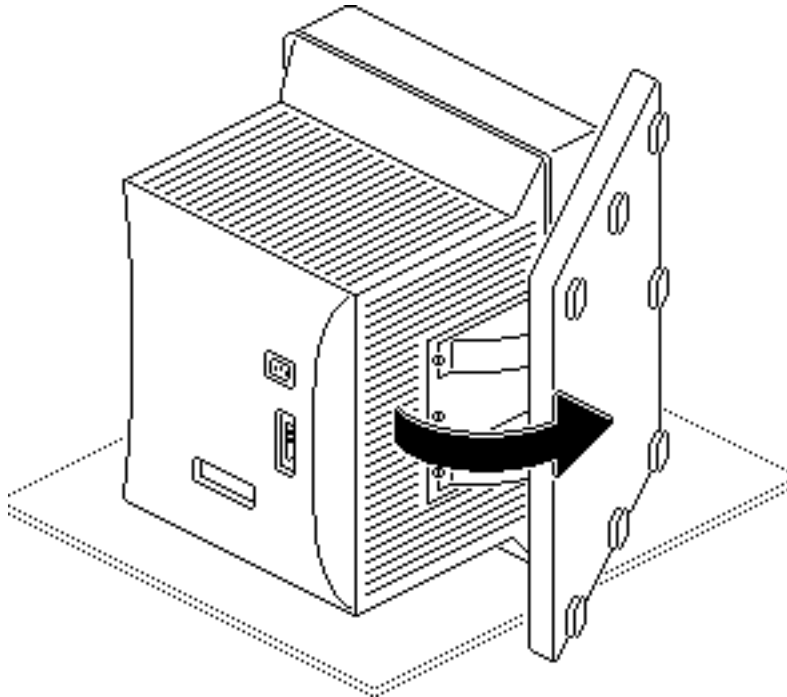

- 3 With one hand, slightly lift up the monitor and rotate the base of the stand until you can reach the three screws that secure the stand to the chassis.



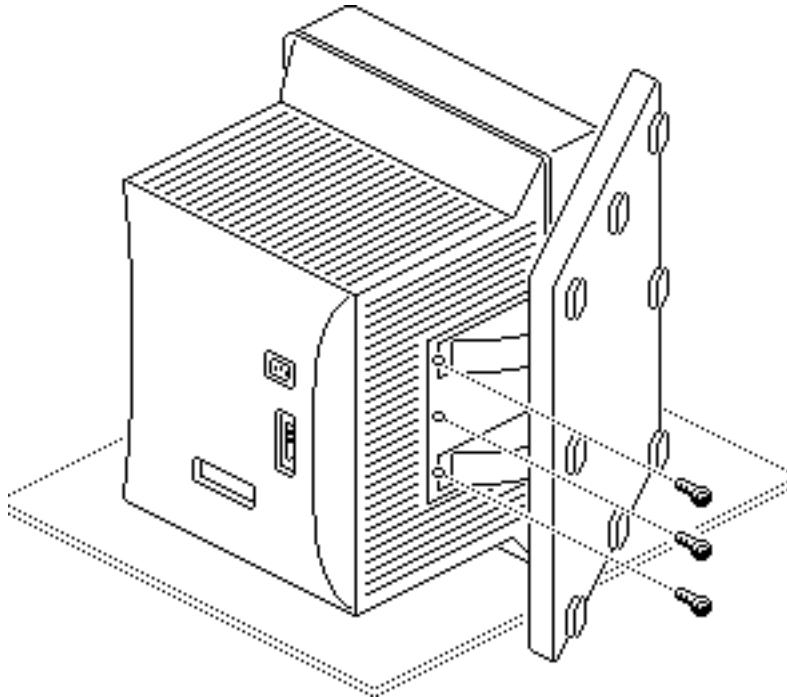

- 4 Remove the three mounting screws.
- 5 Slide the monitor stand back and remove it from the chassis.



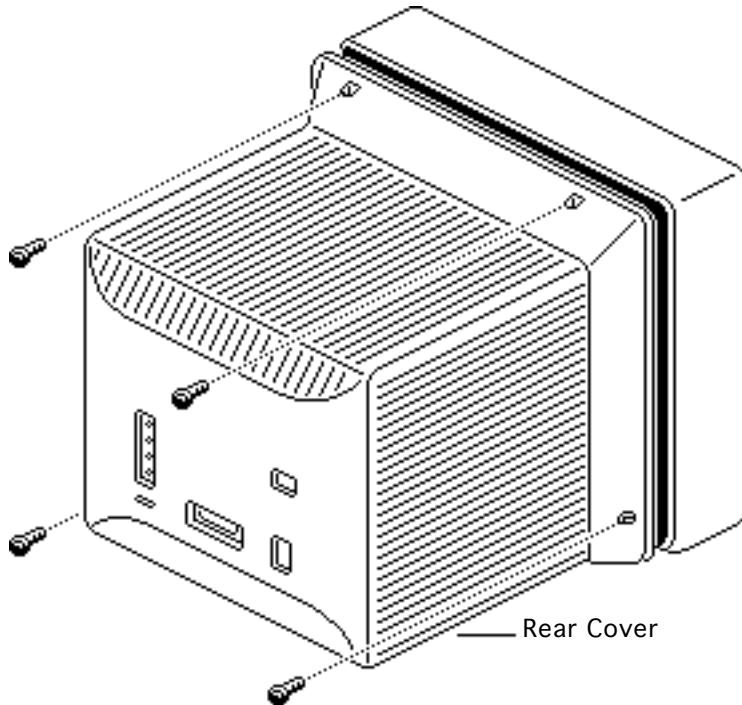

Rear Cover

No preliminary steps are required before you begin this procedure.

⚠ Warning: This product contains high voltage and a high-vacuum picture tube. To prevent serious injury, review CRT safety in Bulletins/Safety.

- 1 Remove the four cover mounting screws.
- 2 Pull the rear cover off the bezel.



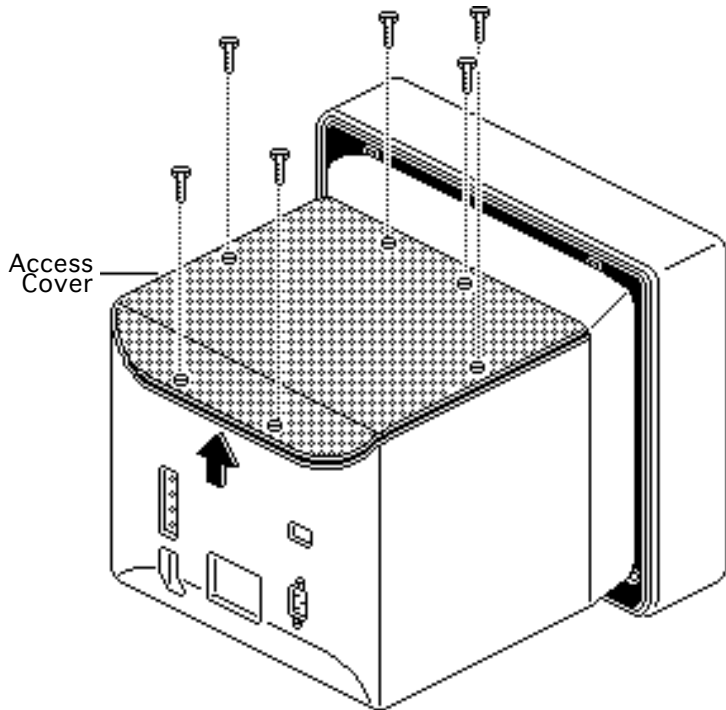

Access Cover

Before you begin, remove the rear cover.

⚠ Warning: This product contains high voltage and a high-vacuum picture tube. To prevent serious injury, review CRT safety in Bulletins/Safety.

- 1 Remove the six mounting screws and lockwashers that hold the access cover in place.
- 2 Lift the access cover off the chassis.





Video Board

Before you begin, do the following:

- Remove the rear cover
- Remove the access cover
- Discharge the CRT

⚠ Warning: This product contains high voltage and a high-vacuum picture tube. To prevent serious injury, review CRT safety in Bulletins/Safety.

Warning: Never use a grounding wriststrap until after discharging the CRT.

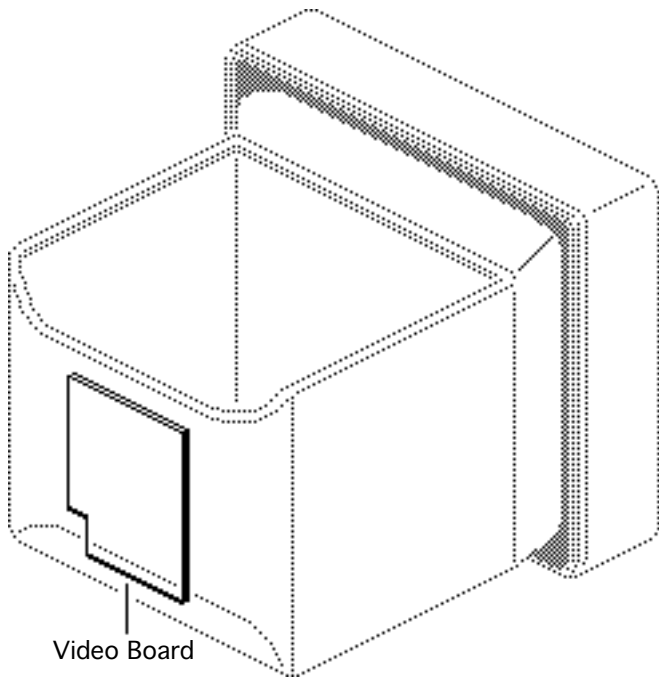



Disconnect the following cable connectors from the video board:

- 13-wire (white) cable from J601
- 11-wire (white) cable from J602
- 6-wire (white) cable from J603
- 2-wire (red/orange) cable from J604

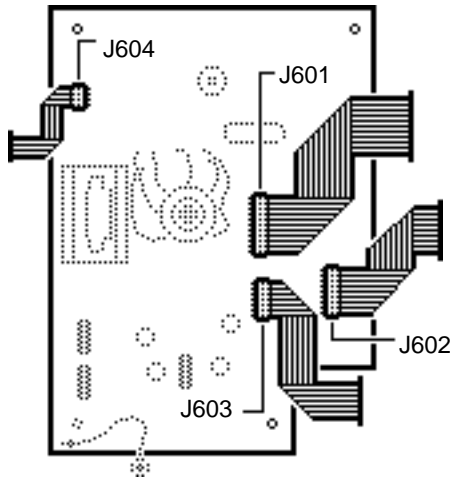



Caution: Do not remove the connectors by pulling on the connector cables. If the connectors are difficult to disconnect, slip a jeweler's screwdriver between the two halves of the connector and carefully pry the halves apart.



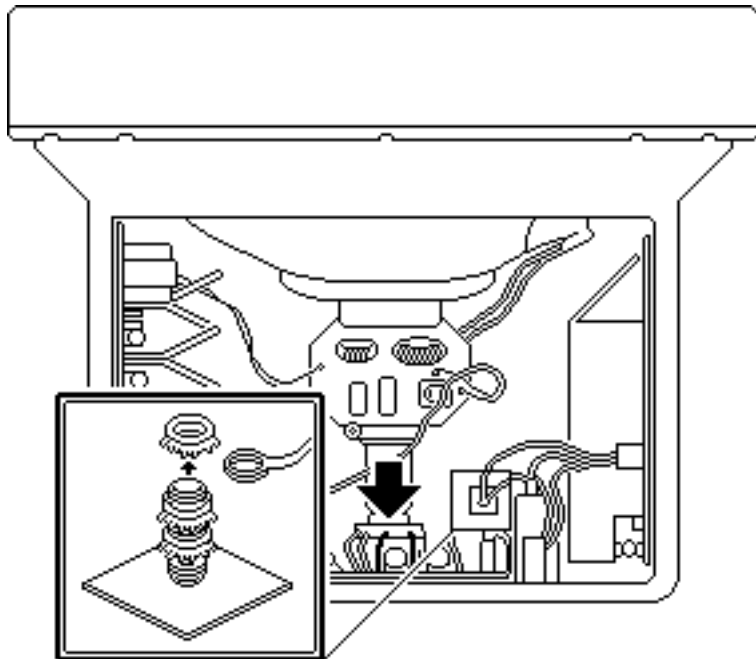

- 1 Remove the hex nut, washer, and green grounding wire from the metal post on the floor of the monitor.
- 2 Pull the CRT socket off the neck of the CRT.



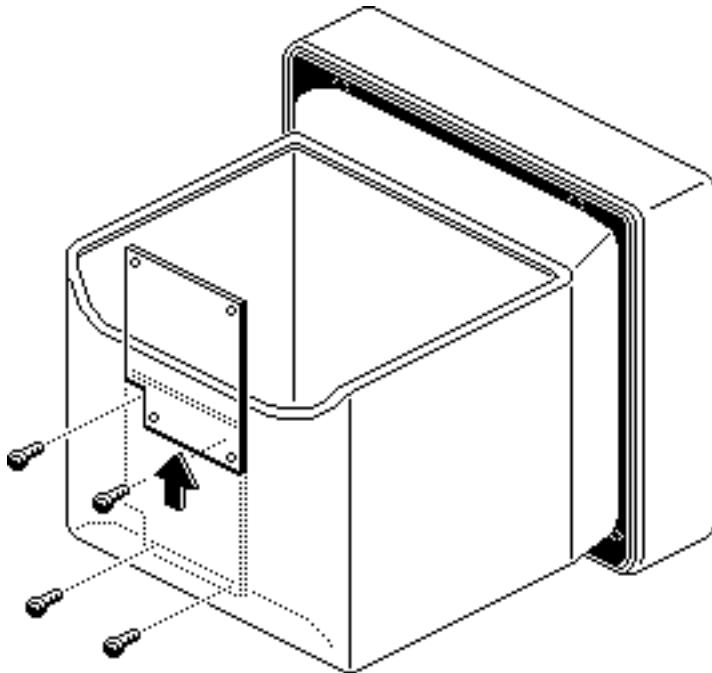

- 3 Remove the four screws that secure the video board to the chassis.
- 4 Carefully lift the video board up and out of the chassis.





Deflection Board

Before you begin, do the following:

- Remove the rear cover
- Remove the access cover
- Discharge the CRT
- Remove the anode cap

⚠ Warning: This product contains high voltage and a high-vacuum picture tube. To prevent serious injury, review CRT safety in Bulletins/Safety.



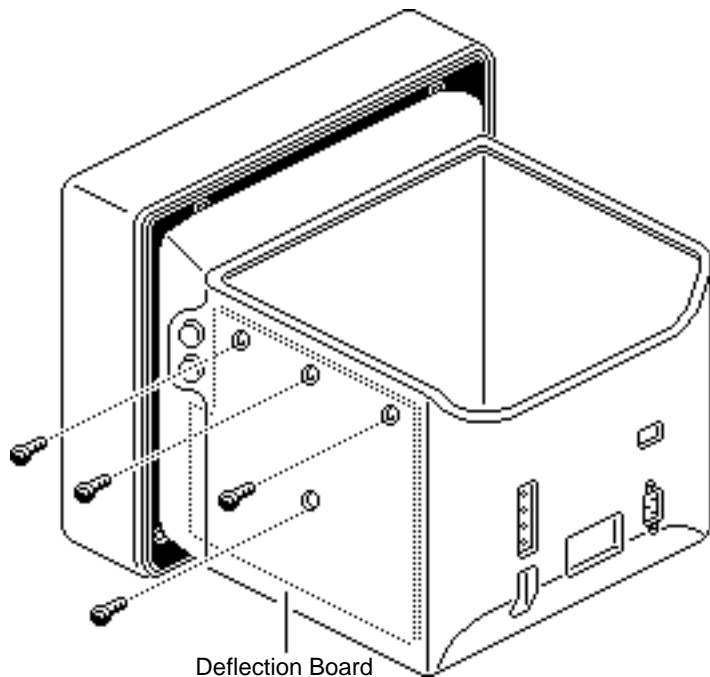

- 1 Remove the four screws that secure the deflection board to the chassis.



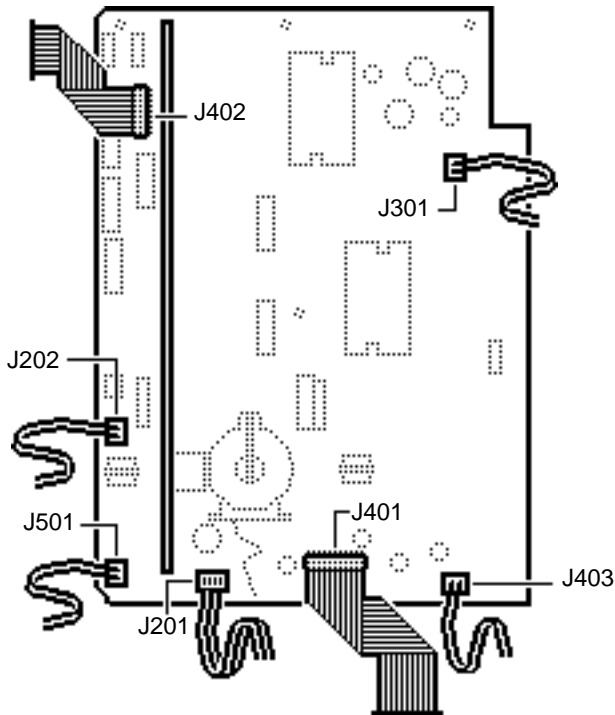

- 2 Disconnect the following cable connectors from the deflection board:
- 11-wire (white) from J402
 - 3-wire (red/blue) from J202
 - 2-wire (red/orange) from J501
 - 5-wire (rd/blk/or/yel) from J201
 - 13-wire (white) from J401
 - 2-wire (gray) from J403
 - 2-wire (yellow/black) from J301





Caution: Do not remove the connectors by pulling on the connector cables. If the connectors are difficult to disconnect, slip a jeweler's screwdriver between the two halves of the connector and carefully pry the halves apart.



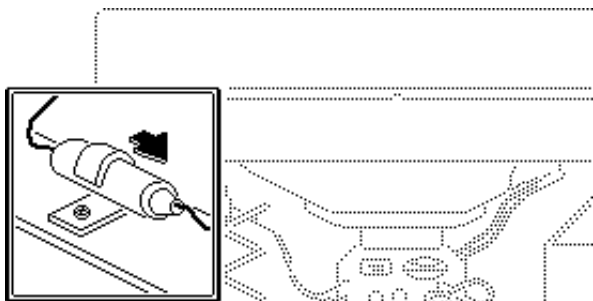

Cigar-shaped Resistor

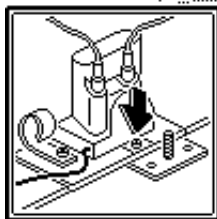

Box-shaped Resistor

- 3 Locate the bleeder resistor on the floor of the monitor.
- 4 If the resistor is cigar-shaped, slide the resistor sideways, pull up slightly on the plastic clip, and remove the resistor.
- 5 If the resistor is box-shaped, remove the screw that holds the resistor. Slide the resistor forward and release it from the metal bracket.



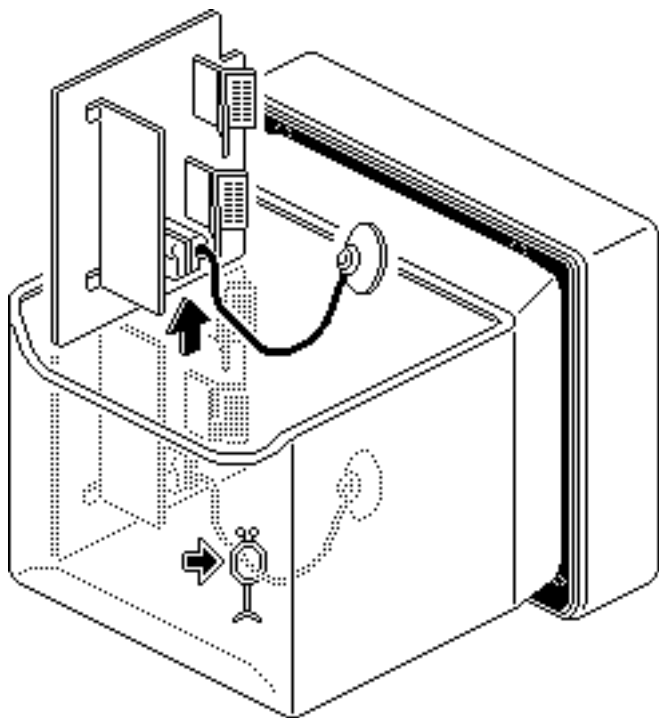

- 6 Remove the anode wire from the plastic cable clamp.
- 7 Lift the deflection board up and out of the chassis.





Power Supply

Before you begin, do the following:

- Remove the rear cover
- Remove the access cover
- Discharge the CRT

⚠ Warning: This product contains high voltage and a high-vacuum picture tube. To prevent serious injury, review CRT safety in Bulletins/Safety.





- 1 Remove the two screws that fasten the power supply to the chassis.

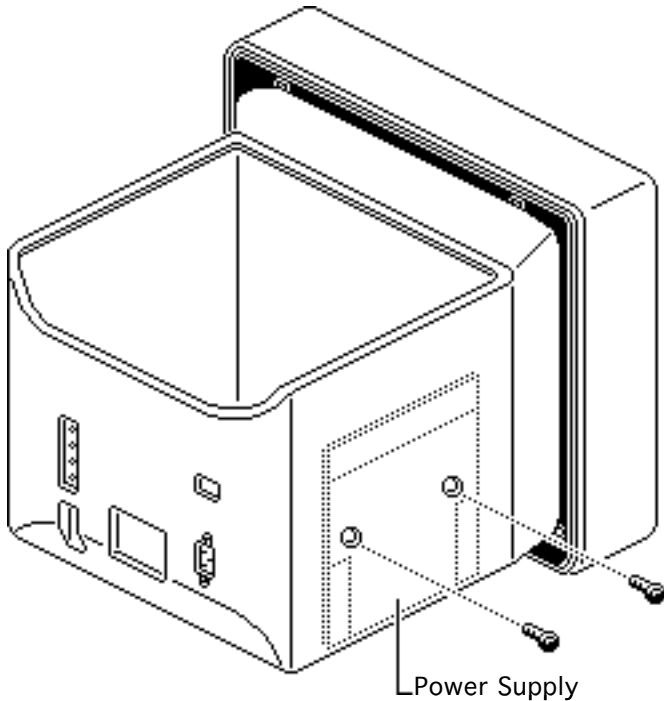

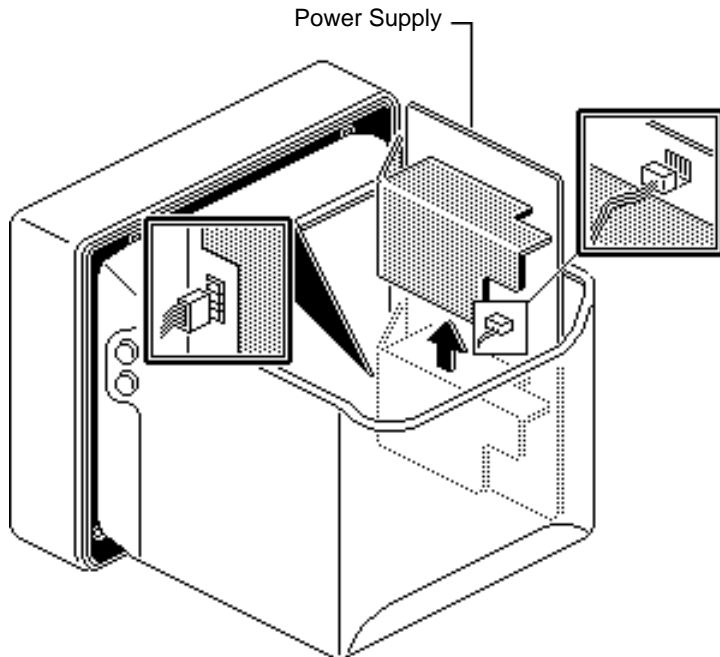

- 2 Disconnect the three-wire connector from the top of the power supply and the five-wire connector from the front of the power supply.
- 3 Carefully lift the power supply from the chassis.



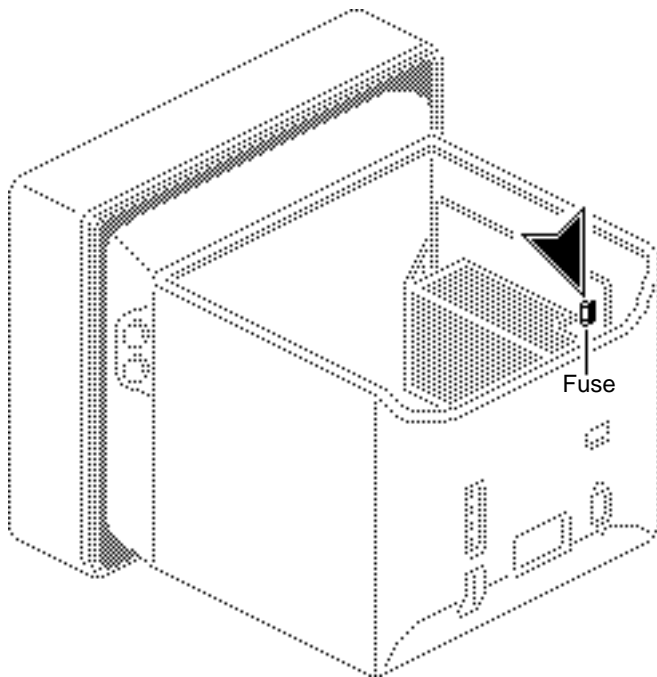

Fuse

Before you begin, do the following:

- Remove the rear cover
- Remove the access cover
- Discharge the CRT

⚠ Warning: This product contains high voltage and a high-vacuum picture tube. To prevent serious injury, review CRT safety in Bulletins/Safety.



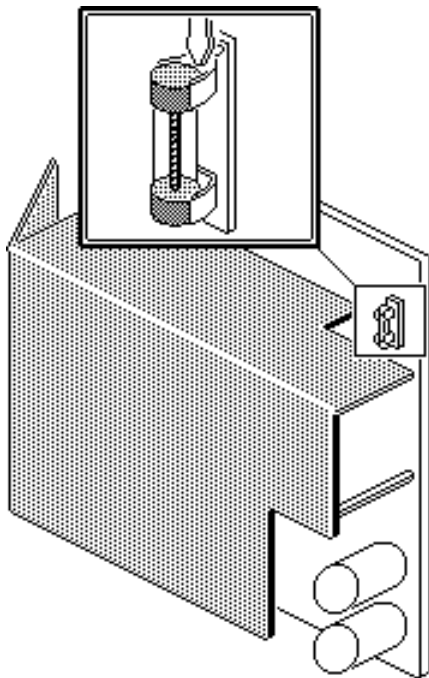

Note: Some units with serial numbers between 43661GXW and 44718HQX have 1.6 A for the fuse on the power supply board. This amperage is incorrect. The correct value is 2.5 A.

Using your fingers or a flat-blade screwdriver, gently pry up one end of the fuse and remove the fuse from the holder.





On/Off Switch

Before you begin, do the following:

- Remove the rear cover
- Remove the access cover
- Discharge the CRT

⚠ Warning: This product contains high voltage and a high-vacuum picture tube. To prevent serious injury, review CRT safety in Bulletins/Safety.

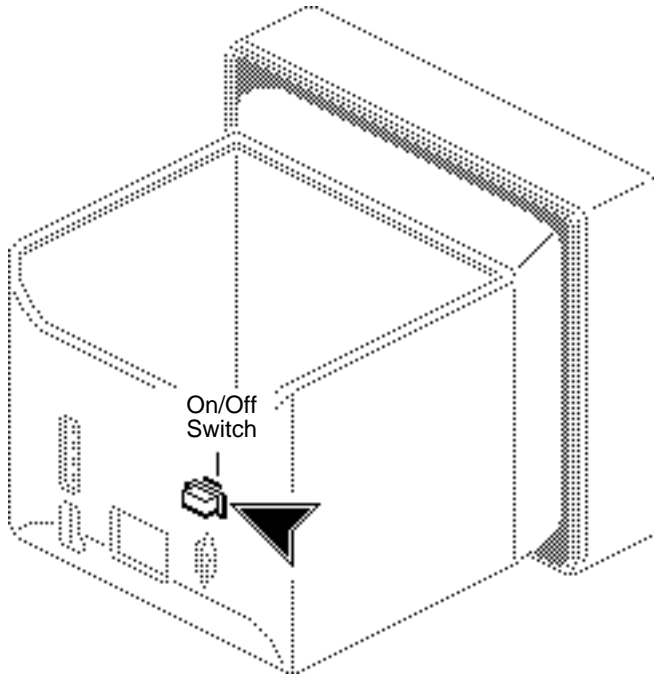

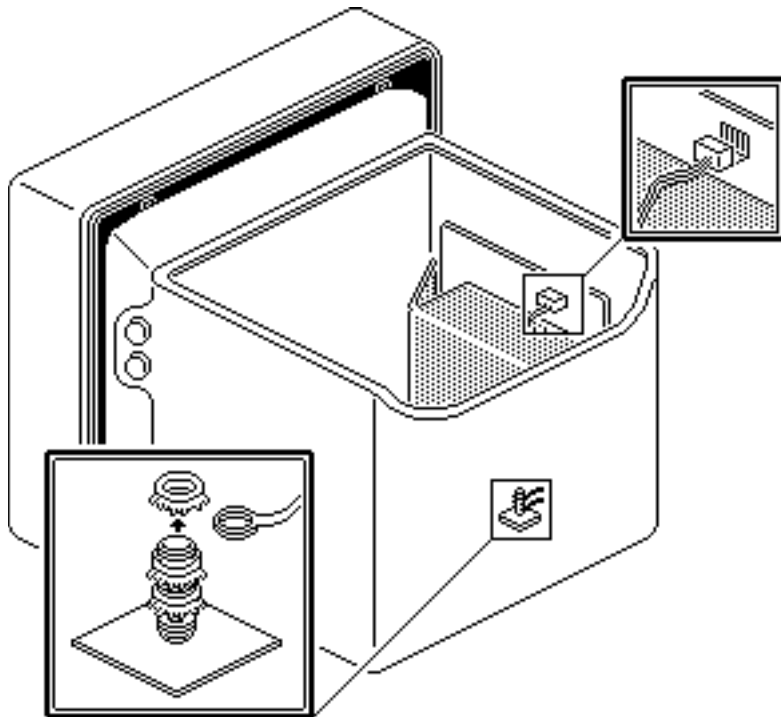

- 1 Remove the three hex nuts, the washers, and the three grounding wires from the metal post on the floor of the monitor.
- 2 Disconnect the 3-wire connector from the top of the power supply.



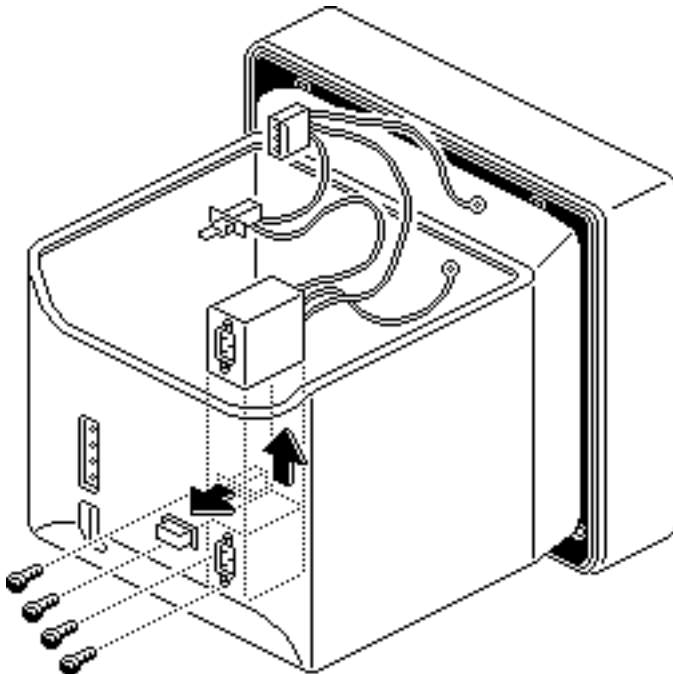

- 3 Pull the plastic knob off the on/off switch.
- 4 Remove the two screws that secure the on/off switch to the chassis.
- 5 Remove the two screws that secure the A/C power socket to the chassis.
- 6 Lift out the on/off switch assembly.





Contrast/ Brightness Assembly

Before you begin, do the following:

- Remove the rear cover
- Remove the access cover
- Discharge the CRT

⚠ Warning: This product contains high voltage and a high-vacuum picture tube. To prevent serious injury, review CRT safety in Bulletins/Safety.

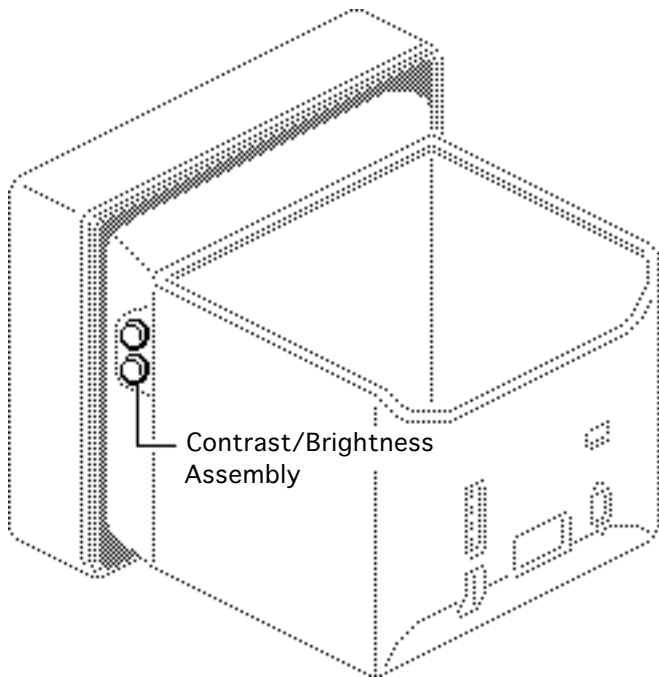

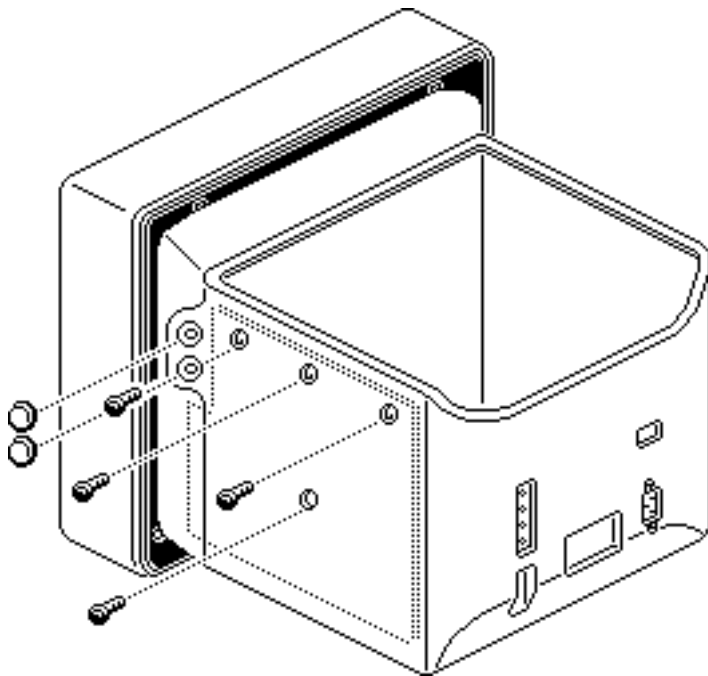

- 1 Pull off the contrast and brightness control knobs.
- 2 Remove the four screws that secure the deflection board to the chassis. Pull the logic board slightly away from the side of the chassis.





- 3 Disconnect the six-wire cable from connector J603 on the video board.

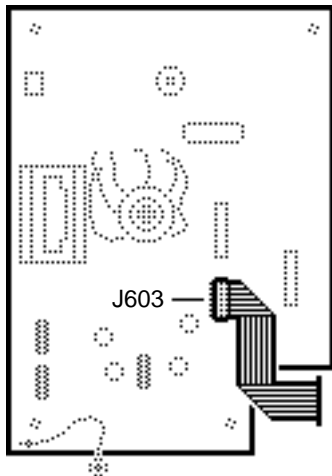



- 4 Remove the two hex nuts and pull the contrast-brightness assembly off the chassis.

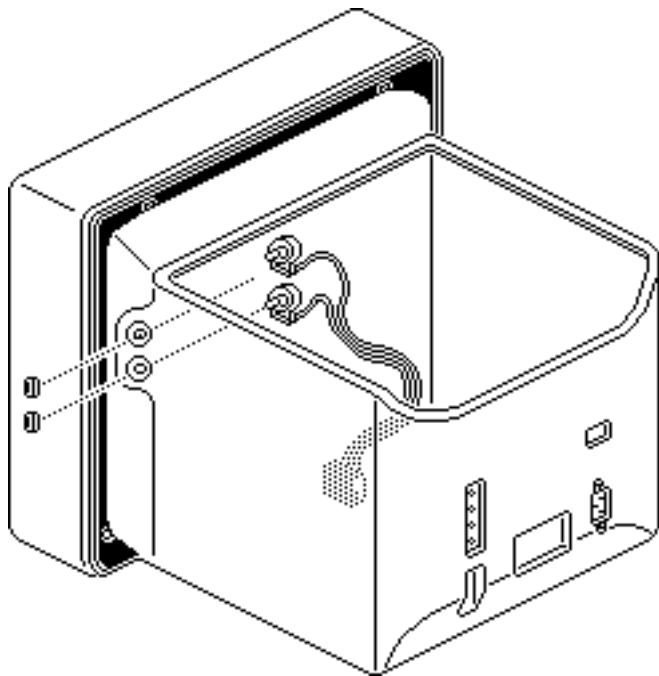



Bezel

Before you begin, do the following:

- Remove the rear cover
- Remove the access cover
- Discharge the CRT

⚠ Warning: This product contains high voltage and a high-vacuum picture tube. To prevent serious injury, review CRT safety in Bulletins/Safety.

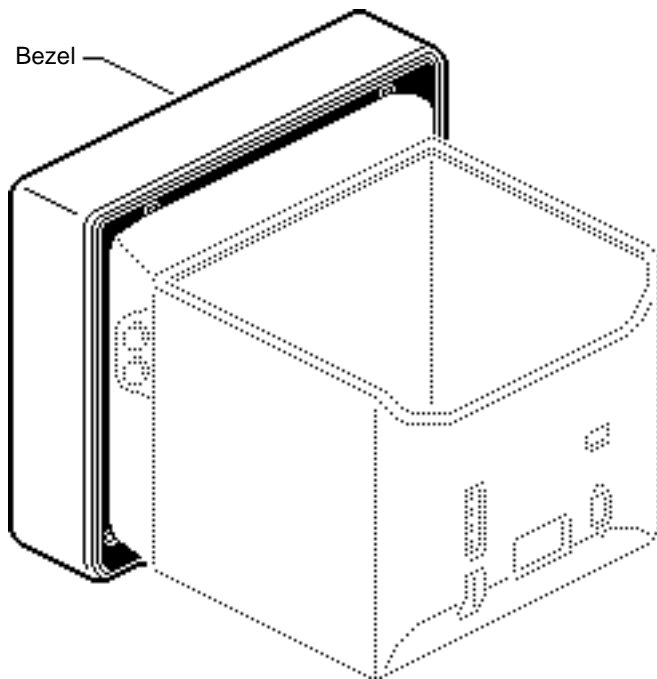

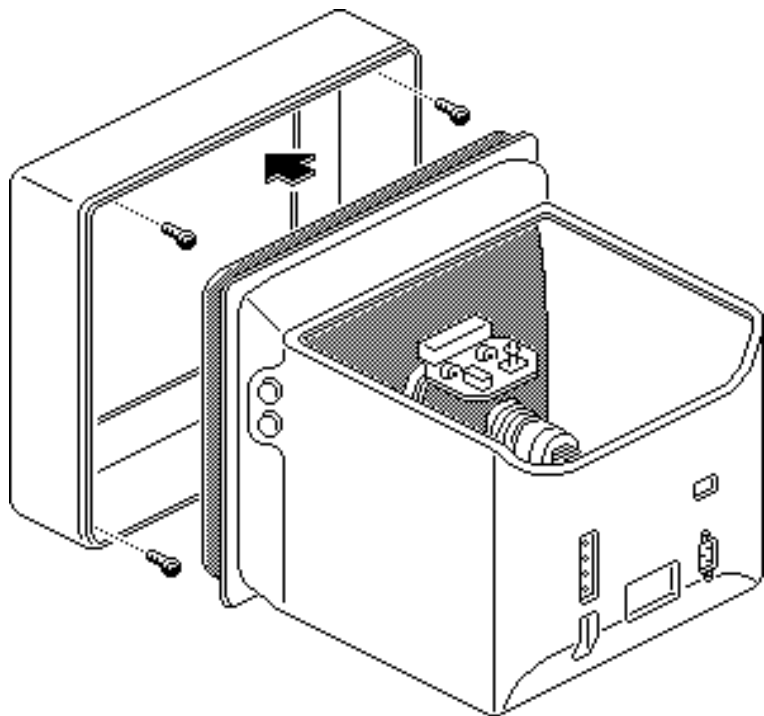

- 1 Remove the four hex nuts that secure the bezel to the chassis.
- 2 Pull the bezel off the chassis.



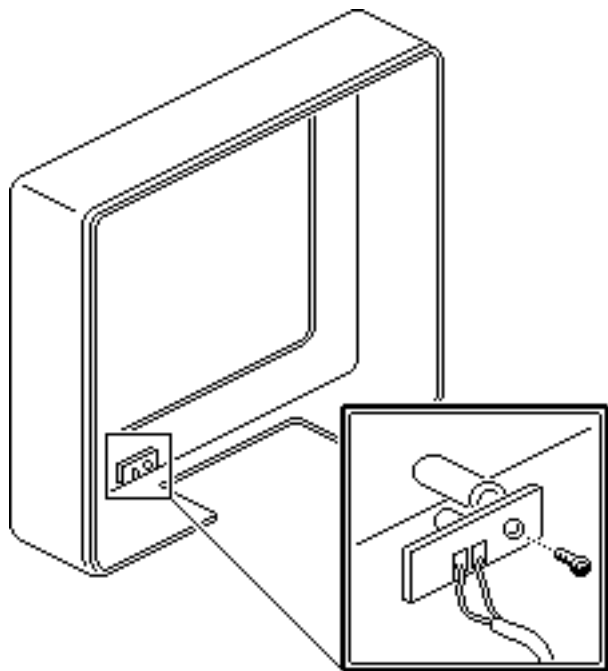

- 3 Remove the hex nut that secures the LED and the black paper baffle to the bezel.



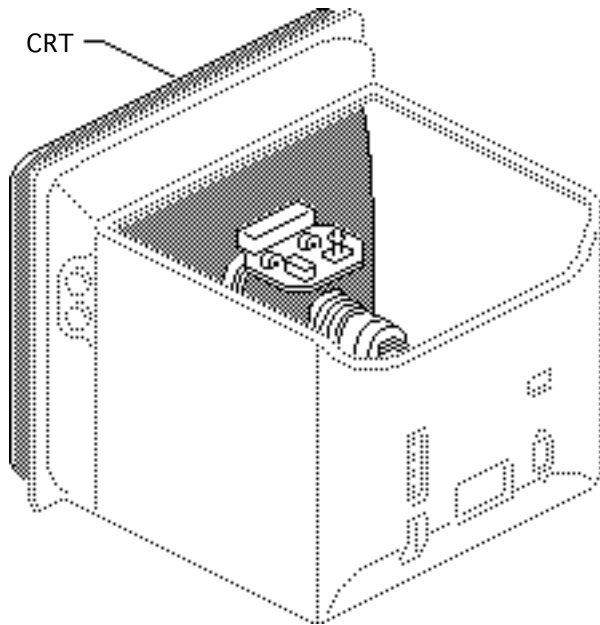

CRT

Before you begin, do the following:

- Remove the rear cover
- Remove the access cover
- Discharge the CRT
- Remove the anode cap
- Remove the bezel
- Remove the swivel stand

⚠ Warning: This product contains high voltage and a high-vacuum picture tube. To prevent serious injury, review CRT safety in Bulletins/Safety.



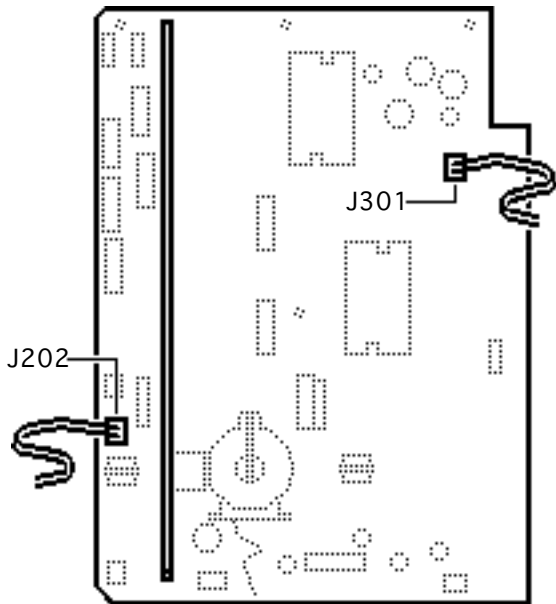

- 1 Disconnect the following cable connectors from the deflection board:
 - 3-wire (CRT neck) from J202
 - 2-wire (CRT neck) from J301





- 2 Pull the CRT socket off the neck of the CRT.

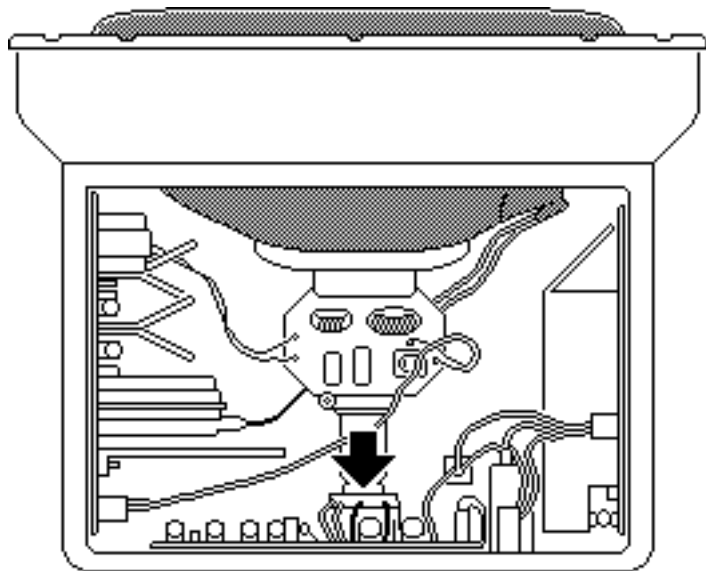

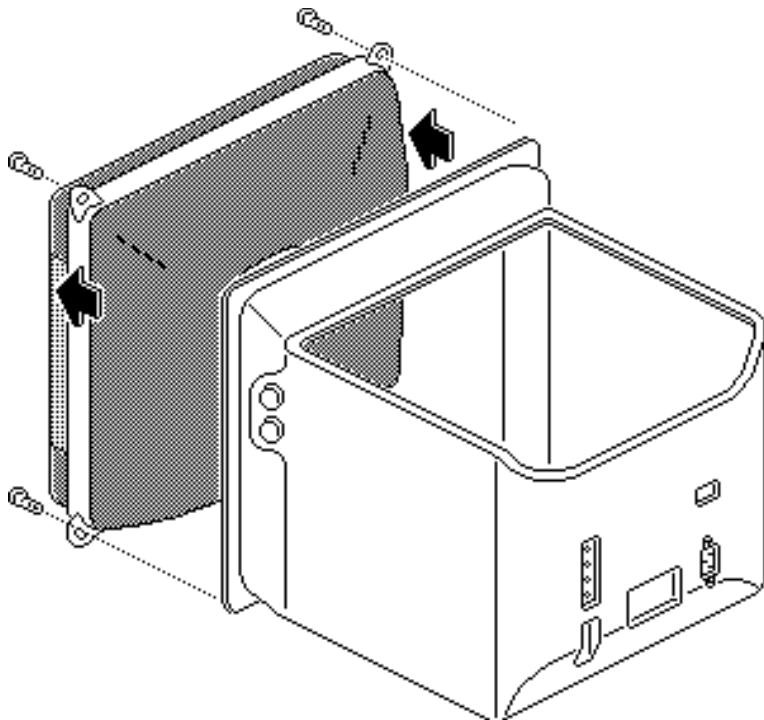

- 3 While supporting the CRT with one hand, remove the four screws and washers that secure the CRT to the chassis frame. Save the washers to use on the replacement CRT.

⚠ Warning: Do not handle the CRT by the neck!

- 4 Carefully grasp the sides of the CRT and lift the CRT out of the chassis.



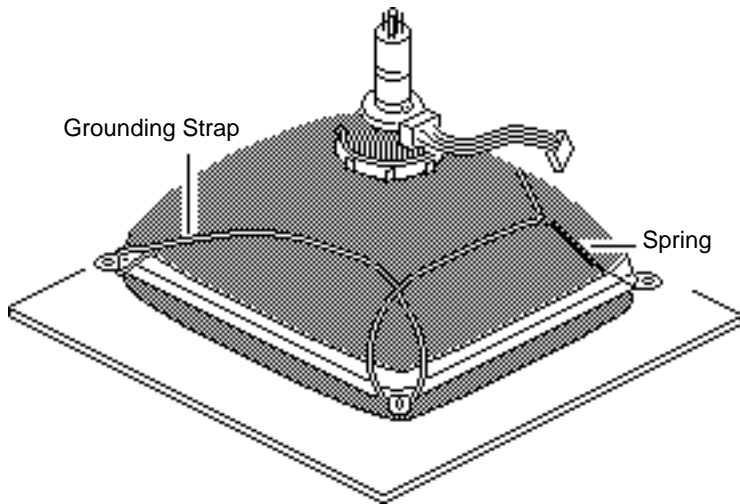

- 5 Place the CRT face-down on a soft, protective surface.
- 6 Remove the grounding strap and the spring. Save them to use on the replacement CRT.

⚠ Warning: If the CRT is cracked or broken, refer to the CRT disposal instructions in Bulletins/Safety.





LED Assembly

Before you begin, do the following:

- Remove the rear cover
- Remove the access cover
- Discharge the CRT
- Remove the anode cap
- Remove the bezel
- Remove the swivel stand
- Remove the CRT

⚠ Warning: This product contains high voltage and a high-vacuum picture tube. To prevent serious injury, review CRT safety in Bulletins/Safety.

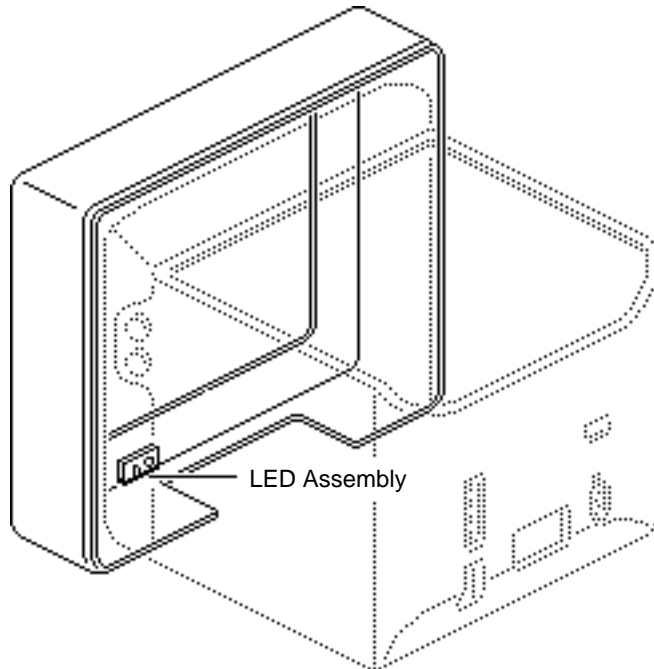

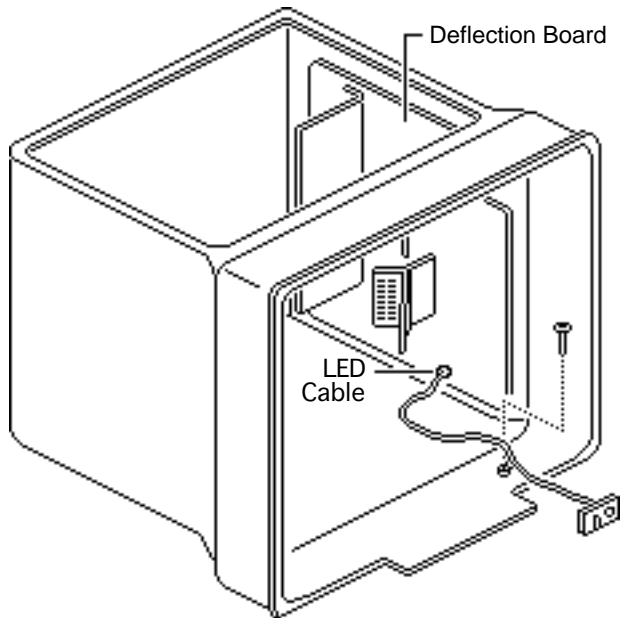

- 1 Disconnect the LED cable from the deflection board.
- 2 Remove the hex nut that secures the green grounding wire to the inside of the chassis. Lift out the LED assembly.





Adjustments

Apple Two-Page Monochrome
Monitor





Geometry

Before you begin, remove the following:

- Rear cover
- Access cover

⚠ Warning: This product contains high voltage and a high-vacuum picture tube. To prevent serious injury, review CRT safety in Bulletins/Safety.

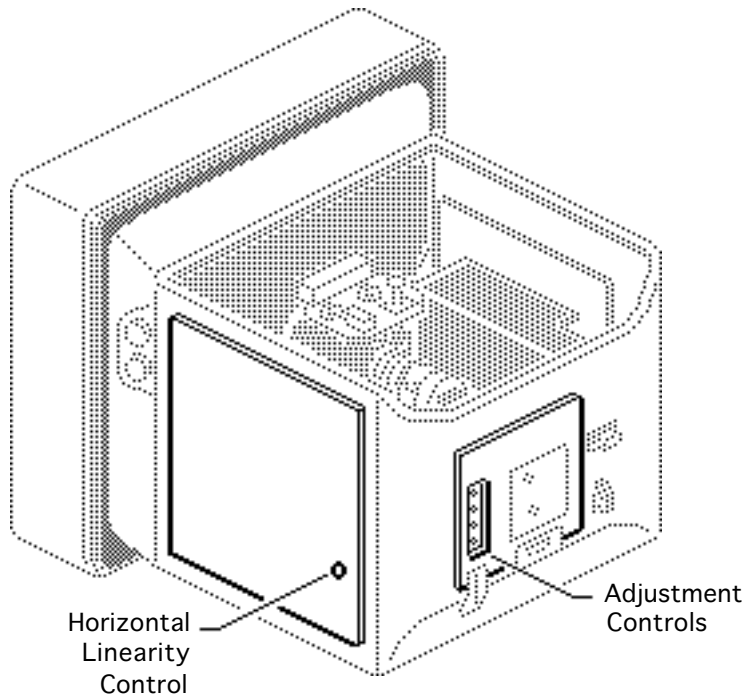



Warning: Because you must make the adjustments from the rear of the computer, position a mirror to view the computer screen. Do not reach around the computer to adjust the controls.

Note: Geometry adjustments should always be performed whenever you replace the CRT, deflection board, or video board.



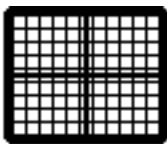
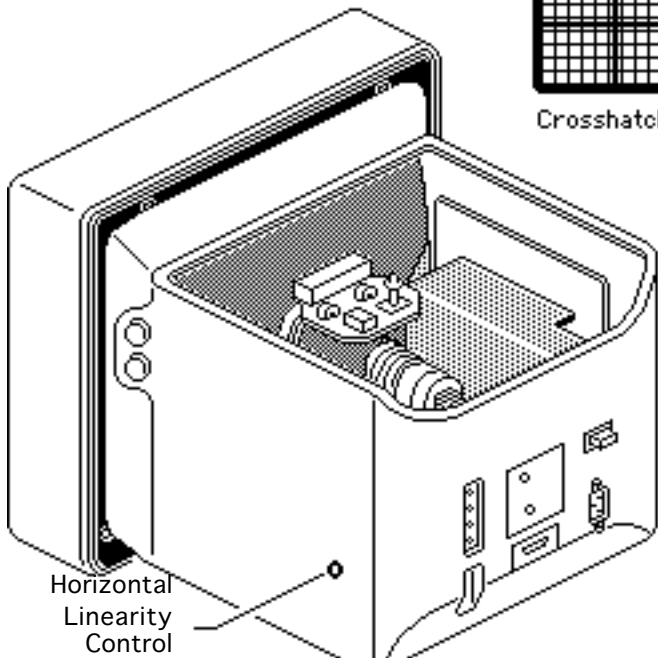

Crosshatch II

Horizontal Linearity

- 1 Use Display Service Utility to display the Crosshatch II (white background) test pattern.

Caution: The linearity adjustment tool is the only tool that can be used to adjust the Horizontal Linearity control! Use of any other tool may damage the adjustment control coil core or cause a short in the monitor's circuitry.



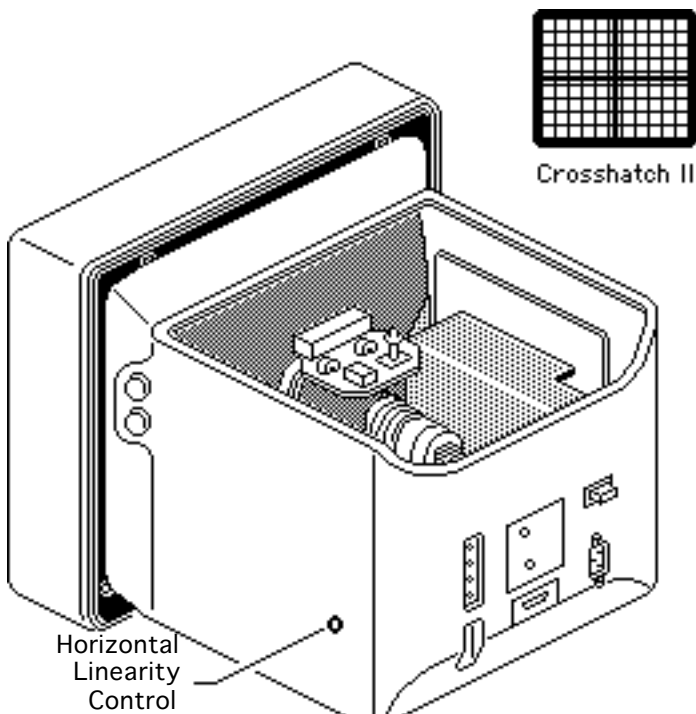

2 Using the linearity adjustment tool, adjust the horizontal linearity control until the raster is as wide as possible.

3 Using the linearity adjustment tool, slowly adjust the horizontal linearity control until the left and right halves of the raster are the same distance from the center of the screen.

- To measure the left half of the raster, place a flexible ruler against the screen





directly over the black horizontal line. Align the zero mark of the ruler with the left edge of the raster. Note the measurement at the point where the two black lines intersect.

- To measure the right half of the raster, align the zero mark of the ruler where the two black lines intersect. Note the measurement at the right edge of the raster.



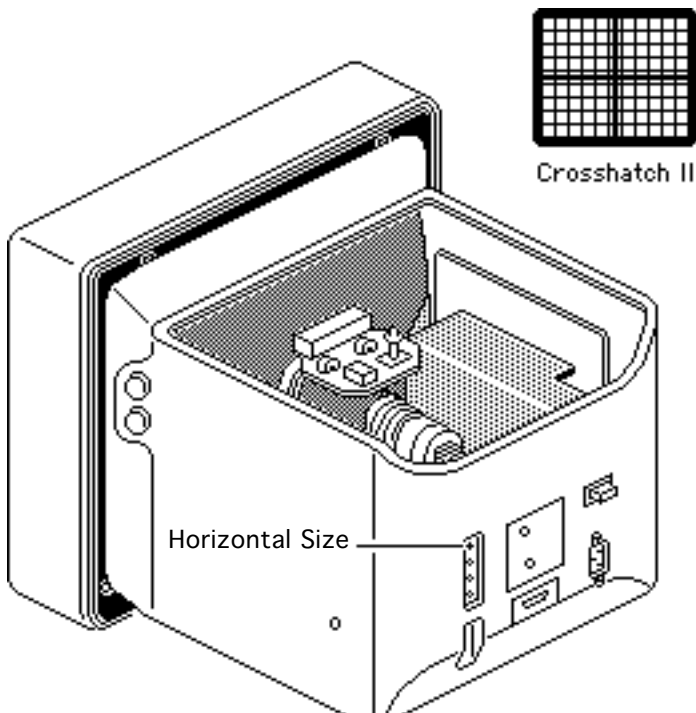

- 4 Using the plastic alignment tool, slowly adjust the horizontal size control until the raster is 15 inches ($\pm 1/8$ ") or 381 mm (± 3 mm) wide.
- 5 Verify that the left and right halves of the raster are still the same distance from the center of the screen. If necessary, adjust the horizontal linearity control.



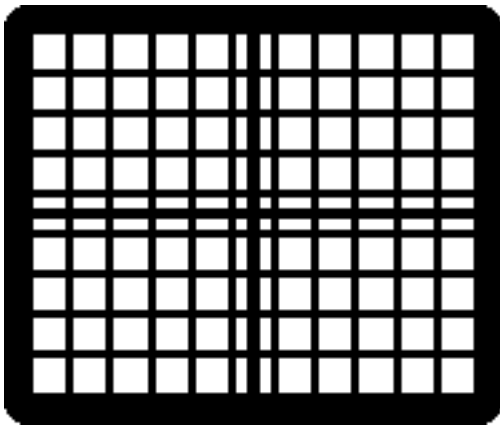

- 6 Verify that the boxes on both the left and right sides of the screen are the same size as the boxes in the center of the screen. If they are not the same size, perform the next step.

⚠ Warning: The monitor operates at extremely high voltages. To prevent electrical shock, use a plastic alignment tool to set the 3-position switch. Avoid touching the heatsink or any other





part of the monitor.

⚠ Warning: If you do not use a plastic alignment tool, turn off the power before reaching inside the chassis and adjusting the switch. Then turn on the power and view the monitor screen.



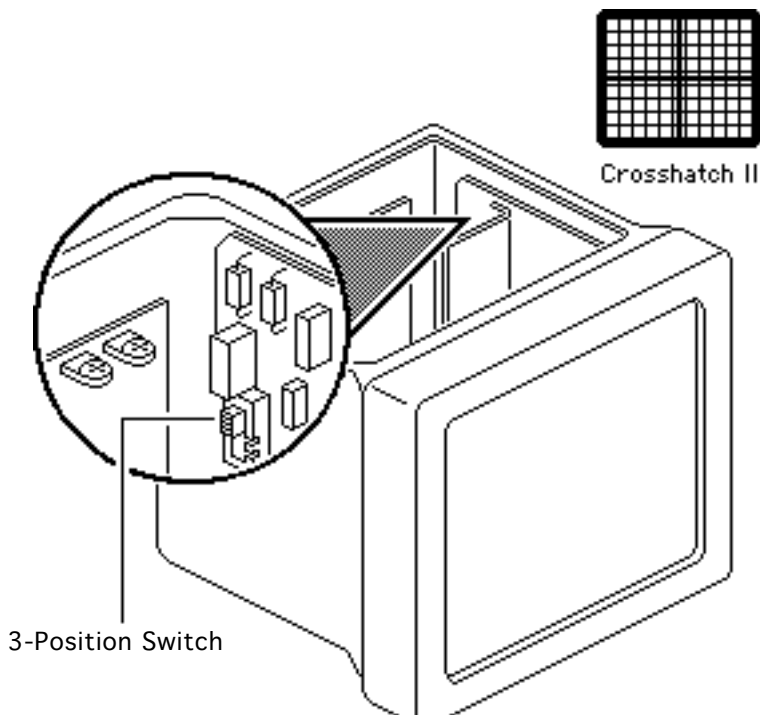

- 7 Using the plastic alignment tool, set the 3-position switch to the lowest of the three settings and recheck the relative size of the boxes. Repeat for all three positions of the switch and select the best position.



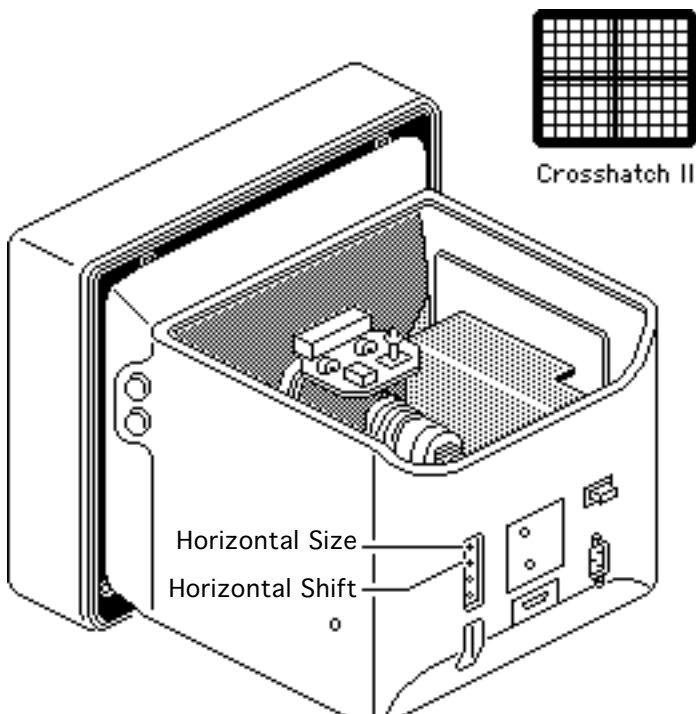

- 8 Using the plastic alignment tool, slowly adjust the horizontal size control until the raster is 15 inches ($\pm 1/8$ ") or 381 mm (± 3 mm) wide.
- 9 Verify that the raster is centered on the screen. If necessary, adjust the horizontal shift control.



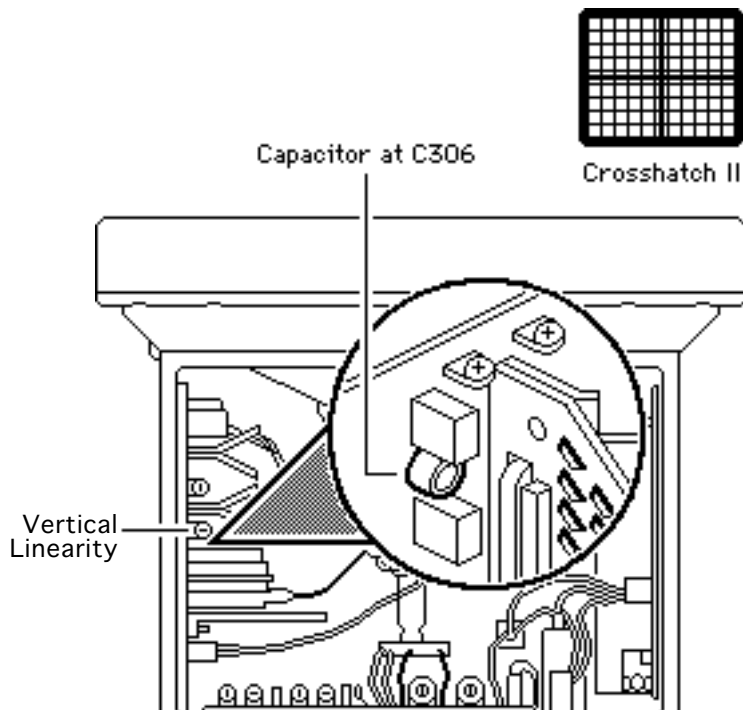

Vertical Linearity

- 1 Use Display Service Utility to display the Crosshatch I or Crosshatch II test pattern.
- 2 Using the plastic alignment tool, adjust the orange capacitor at C306 until the top two rows of boxes are the same height.



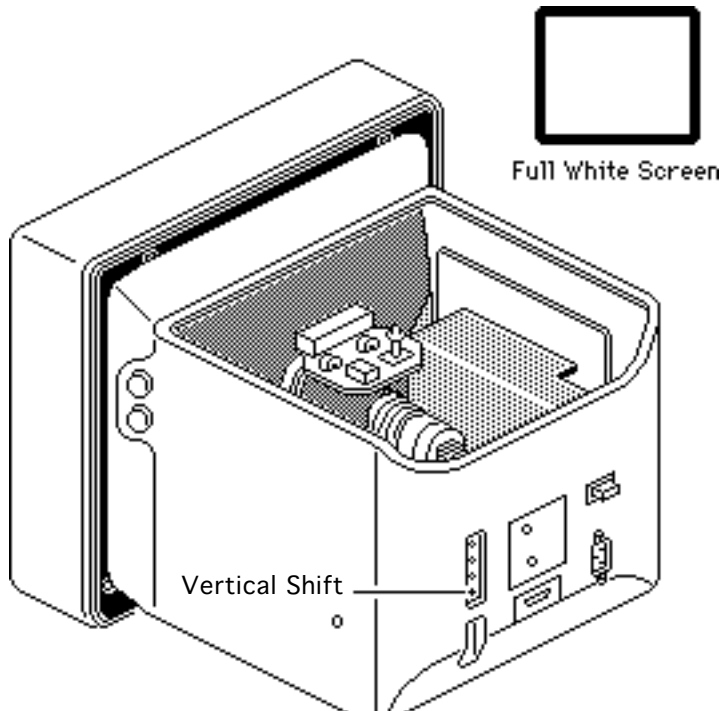

- 3 Using the plastic alignment tool, adjust the vertical linearity control until the top and bottom rows of boxes are the same height.
- 4 Use Display Service Utility to display the Full White Screen test pattern.
- 5 Using the plastic alignment tool, adjust the vertical shift control until the white raster is vertically centered.



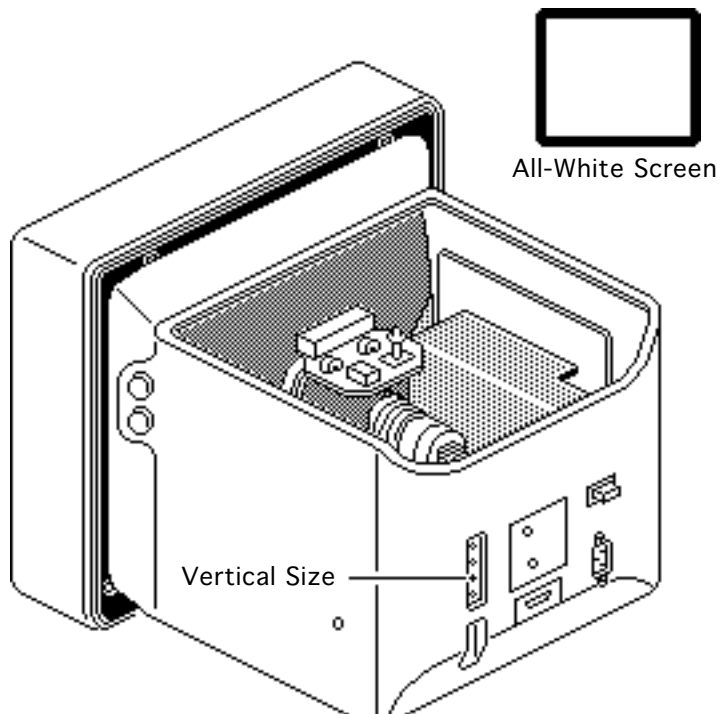

- 6 Use Display Service Utility to display the All-White Screen test pattern.
- 7 Using a plastic alignment tool, adjust the vertical size control until the white raster is $11 \frac{5}{16}$ inches ($\pm 1/8$ ") or 287.3 mm (± 3 mm) high.



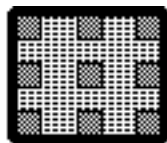

Focus

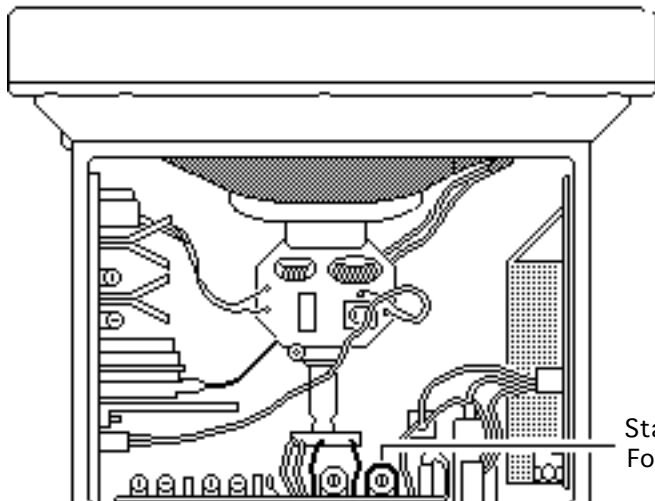

Static Focus

Focus

- 1 Use Display Service Utility to display the Focus test pattern.
- 2 Using a plastic screwdriver, adjust the static focus control for the best focus in the box at the center of the screen.



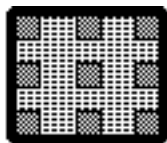

Focus

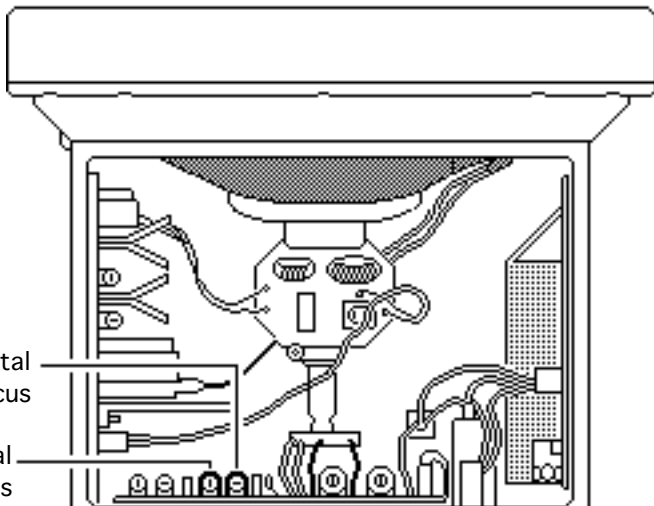

Horizontal
Focus

Vertical
Focus

- 3 Using a plastic screwdriver, adjust the horizontal focus control for the best focus in the box at the left and right sides of the screen.
- 4 Using a plastic screwdriver, adjust the vertical focus control for the best focus in the box at the top and bottom center of the screen.
- 5 Repeat the adjustments until you have attained the best focus possible.



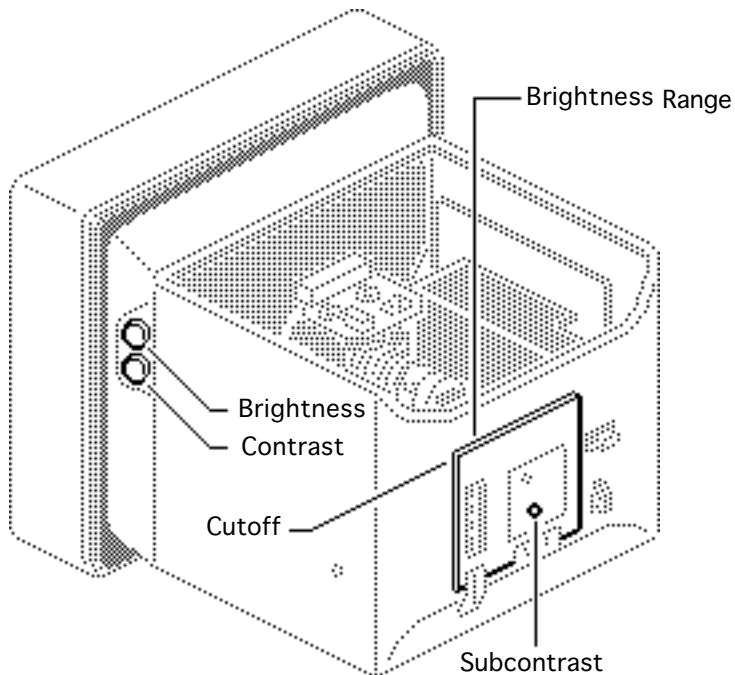

Video

Before you begin, remove the following:

- Rear cover
- Access cover

⚠ Warning: This product contains high voltage and a high-vacuum picture tube. To prevent serious injury, review CRT safety in Bulletins/Safety.





Warning: Because you must make adjustments from the rear of the computer, position a mirror to view the computer screen. Do not reach around the computer to adjust the controls.

Note: Video adjustments should always be performed whenever you replace the CRT, deflection board, or video board.



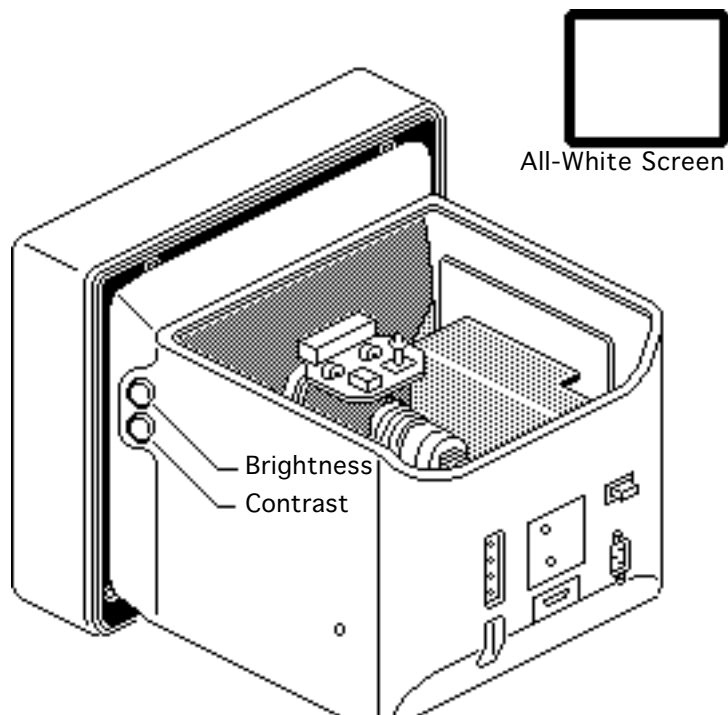

- 1 Switch off the power and remove the video cable from the back of the monitor.
- 2 Set the external (user) contrast knob to maximum (turn fully clockwise) and the brightness knob to the center (detent) position.





All-White Screen

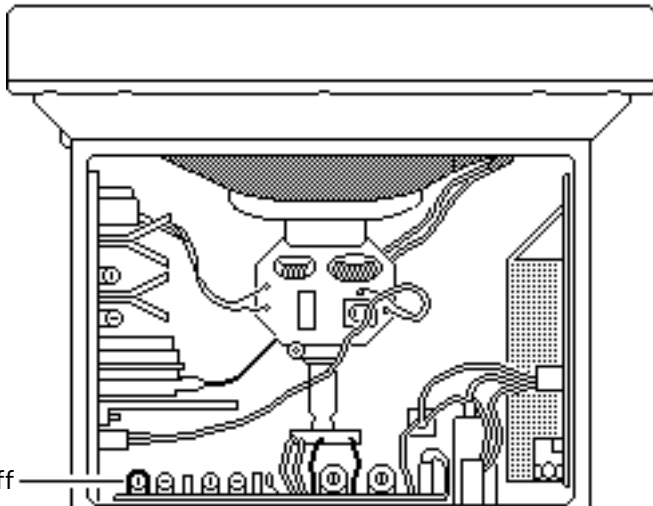

Cutoff

- 3 Using the plastic screwdriver, adjust the cutoff control to minimum (turn fully counterclockwise).
- 4 Switch on the power and wait 20 minutes for the monitor to warm up.
- 5 Use Display Service Utility to display the All-White Screen test pattern.





All-White Screen

Note: The Cutoff adjustment should be performed in a dimly lit room after the monitor has been on for at least 20 minutes.

- 6 Using the plastic screwdriver, turn the cutoff control clockwise until a white raster just appears, then turn counterclockwise until the raster just fades to black.
- 7 Switch off the power and reconnect the video cable.

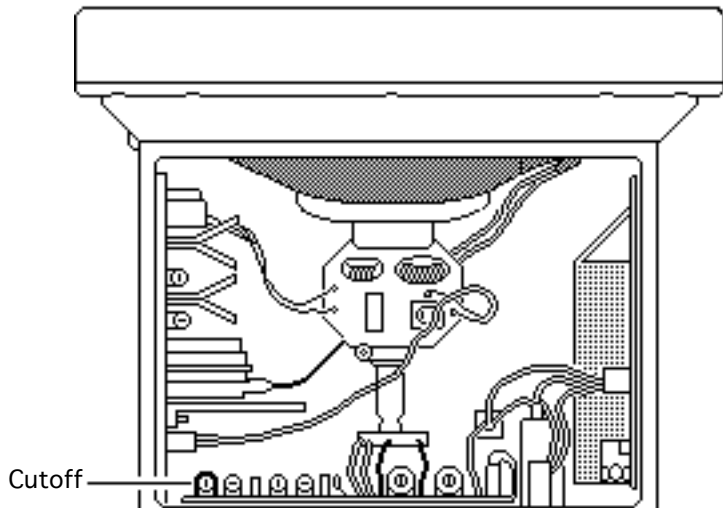



- 8 Switch on the power.

Note: If the power is turned off for more than a few seconds, you must wait for another 20 minutes for the monitor to warm up.



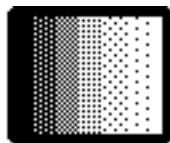

Gray Bars

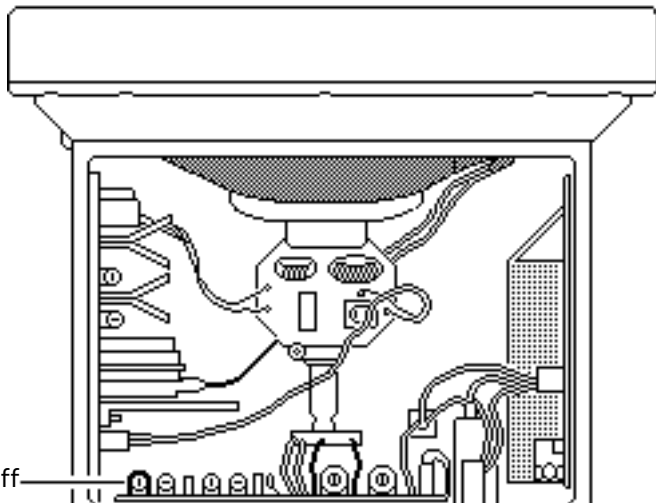

- 9 Use Display Service Utility to display the Gray Bars test pattern.
- 10 Using a plastic alignment tool, adjust the cutoff control until the leftmost bar (darkest) is black and the next bar is barely distinguishable from the black bar.

Cutoff



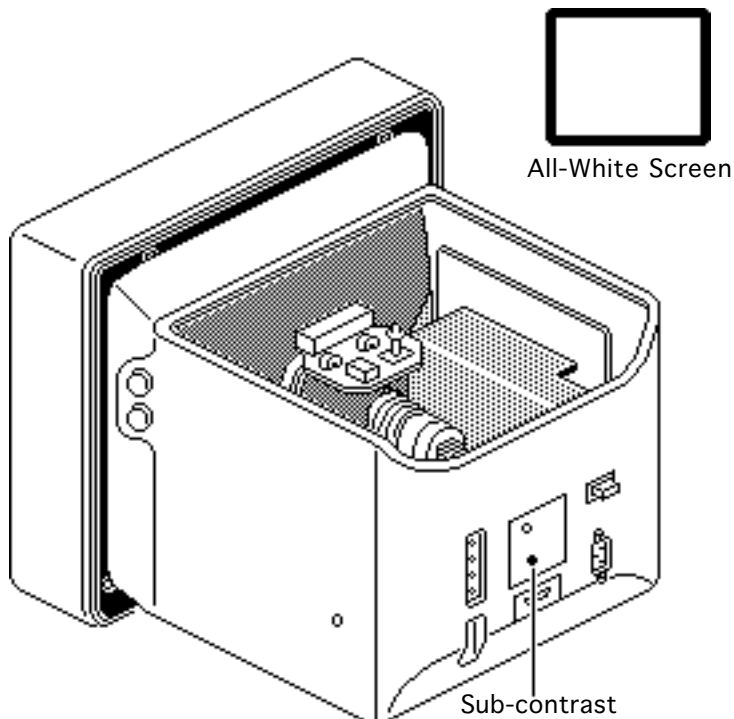

Important: Readings from light meters R77, L-248, and 246 differ. Please note which meter you are using before making adjustments. (See “Light Meter Setup.”)

- 11 Using Display Service Utility, display the All-White Screen test pattern.





- 12 Using the light meter and a two-inch plastic screwdriver, adjust the sub-contrast control until you get 31 foot lamberts (± 3 foot lamberts), which on the light meter is
- Model R77: 23 on the bottom scale
 - Model L-248: middle of the 10 scale
 - Model 246: 23 on the red scale





All-White Screen

Important: Over time, light meter tolerances can vary. If you doubt your meter's accuracy, verify the readings with a known-good light meter or photometer.

- 13 Set the external (user) brightness knob to maximum (turn fully clockwise).

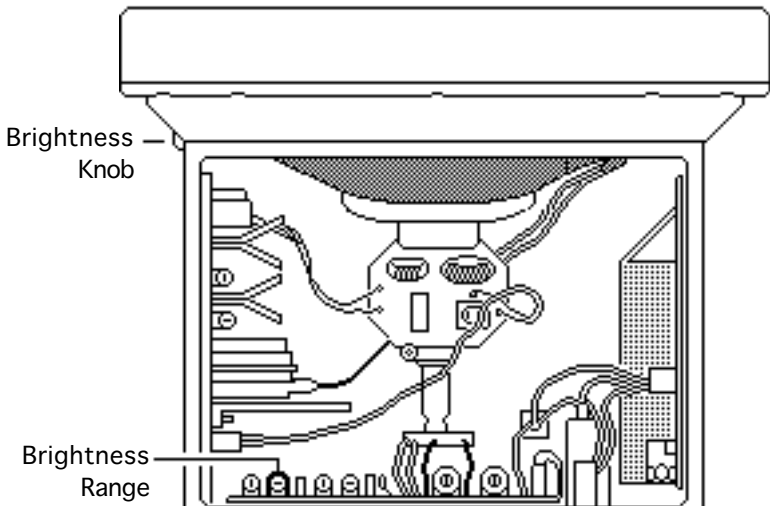



- 14 Using the plastic screwdriver, adjust the brightness range control until you get 31 foot lamberts (± 3 foot lamberts), which on the light meter is
 - Model R77: 23 on the bottom scale
 - Model L-248: middle of the 10 scale
 - Model 246: 23 on the red scale
- 15 Reset the brightness knob to the center (detent) position.





Light Meter Setup

This topic covers setup for three light meter models: R77, L-248, and 246. Model R77 (Apple part number 076-0310) is the newest model available.

Model R77

The R77 light meter is capable of reading luminance from 10 to 1,000 footcandles (fc).

Before you begin, remove the 10X multiplier plate



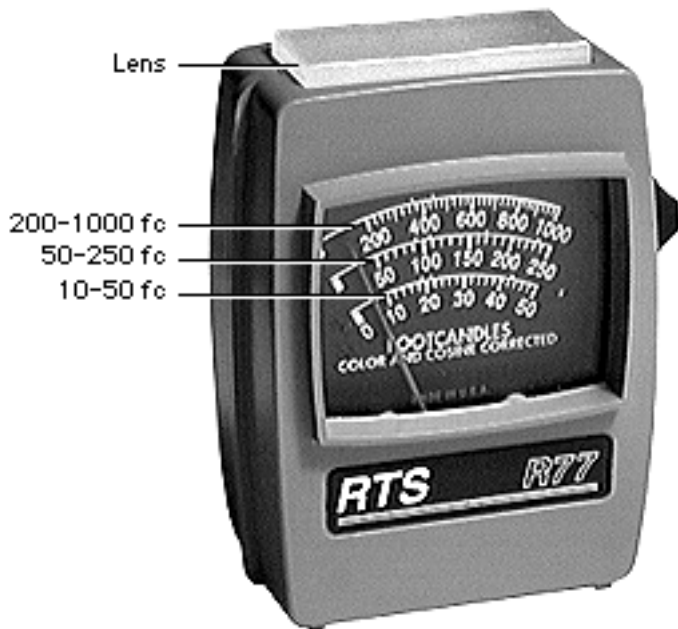

from the lens.

Three scales are shown on the light meter:

- 200-1000 fc
- 50-250 fc
- 10-50 fc

Because display screen luminance typically ranges from 10 to 50 fc, take readings from the bottom scale only.



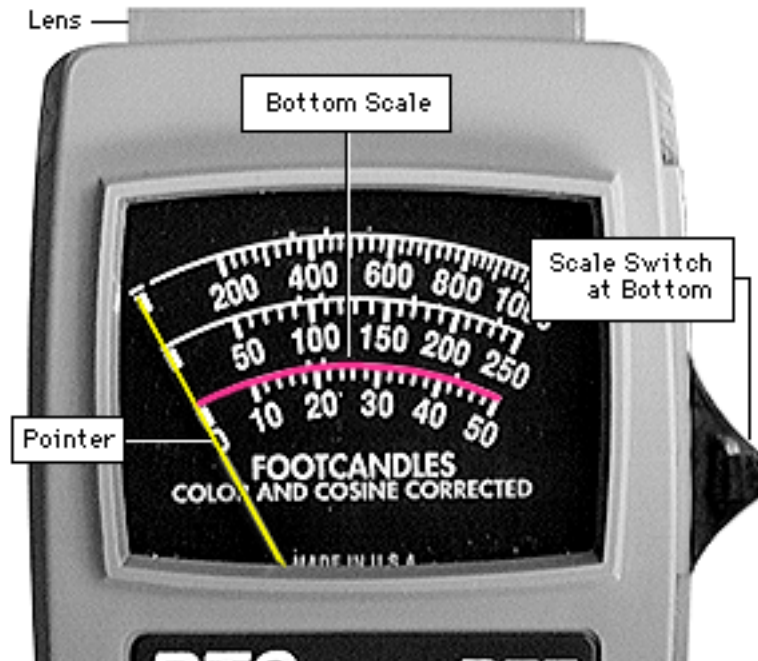

To measure a display screen's luminance,

- 1 Set the scale switch to the bottom position (to set up the 10-50 fc scale).
- 2 Place the lens against the middle of the screen and read the bottom scale.

Note: When the light meter is not in use, slide the scale switch to its top position, and store the meter in its protective case.

Important: If you suspect the light meter is giving false



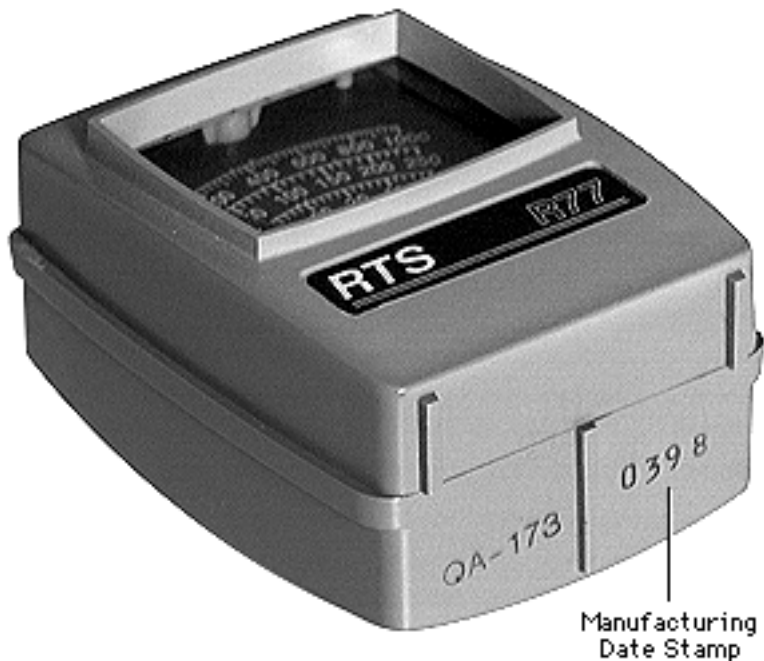

readings, verify the readings with a known-good light meter or photometer. Also check the age of the R77 light meter by its four-digit manufacturing date stamp (such as 0398 for March 1998).

Caution: Dropping the meter can permanently damage its accuracy. A shock-damaged meter might read incorrectly or its pointer may not drop to zero.



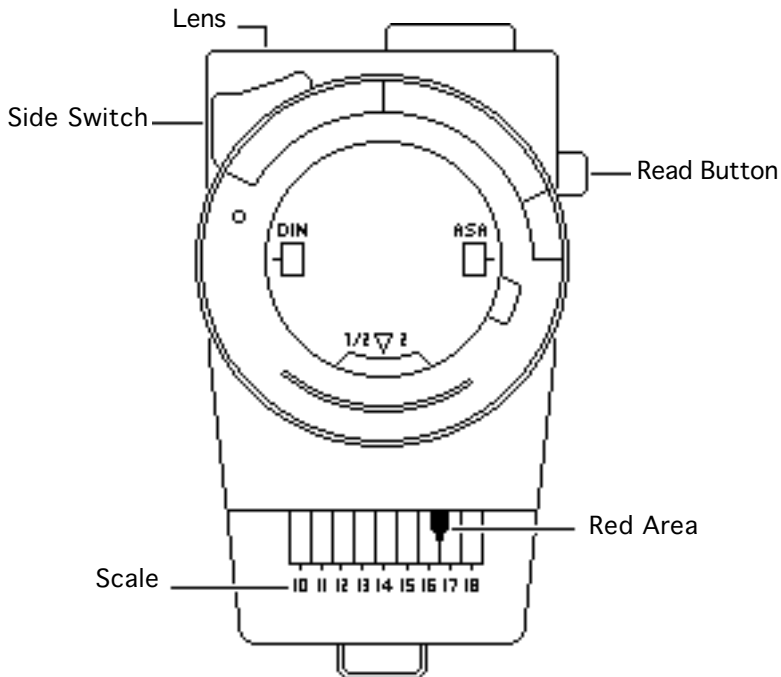

Model L-248

- 1 Press the red button on the back of the light meter. If the reading is out of the red area, replace the battery.
- 2 Move the side switch to its upper position so that the scale reads 10 through 18.
- 3 Uncover the lens of the meter.
- 4 Place the lens against the middle of the screen and press the read button to read the scale.



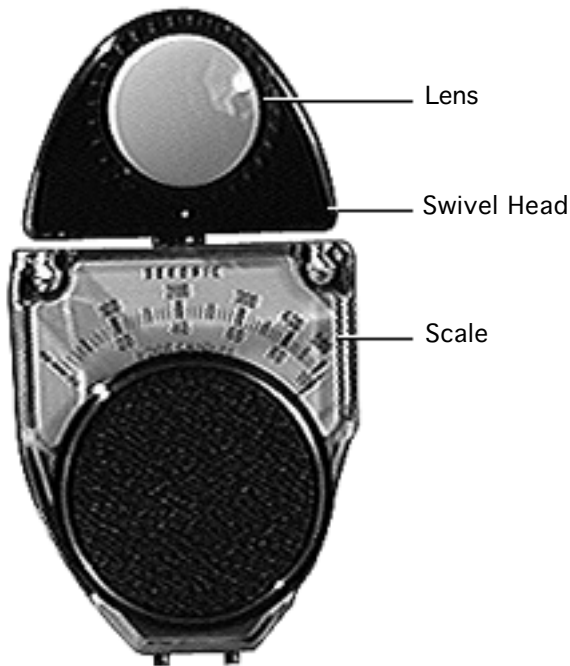

Model 246

- 1 Remove the metal slide, if installed, from the top of the light meter.
- 2 Install the white lens with the red dot.
- 3 Rotate the swivel head so the lens of the meter faces the monitor.
- 4 Place the lens against the middle of the screen and read the scale.





Exploded View

Apple Two-Page Monochrome
Monitor



