

PCG-FX290/FX290K

SERVICE MANUAL

US Model
Canadian Model

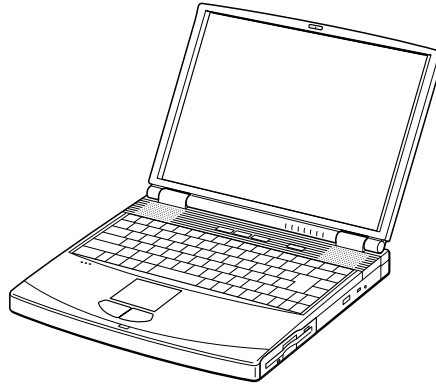

Illust : PCG-FX290K



Confidential

NOTEBOOK COMPUTER

SONY®

Information in this document is subject to change without notice.

Sony and VAIO are trademarks of Sony. Intel logo and Intel Inside logo are registered trademarks of Intel Corporation. Pentium MMX is a trademark of Intel Corporation. Microsoft, MS-DOS, Windows, the Windows 95 and Windows 98 logo are trademarks of Microsoft Corporation.

All other trademarks are trademarks or registered trademarks of their respective owners. Other trademarks and trade names may be used in this document to refer to the entities claiming the marks and names or their products. Sony Corporation disclaims any proprietary interest in trademarks and trade names other than its own.

Caution Markings for Lithium/Ion Battery - The following or similar texts shall be provided on battery pack of equipment or in both the operating and the service instructions.

CAUTION: Danger of explosion if battery is incorrectly replaced. Replace only with the same or equivalent type recommended by the manufacturer. Discard used batteries according to the manufacturer's instructions.

CAUTION: The battery pack used in this device may present a fire or chemical burn hazard if mistreated. Do not disassemble, heat above 100°C (212°F) or incinerate.

Dispose of used battery promptly.
Keep away from children.

CAUTION: Changing the back up battery.

- Overcharging, short circuiting, reverse charging, mutilation or incineration of the cells must be avoided to prevent one or more of the following occurrences; release of toxic materials, release of hydrogen and/or oxygen gas, rise in surface temperature.
- If a cell has leaked or vented, it should be replaced immediately while avoiding to touch it without any protection.

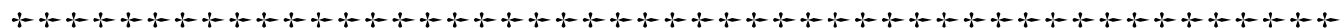

Service and Inspection Precautions

1. Obey precautionary markings and instructions

Labels and stamps on the cabinet, chassis, and components identify areas requiring special precautions. Be sure to observe these precautions, as well as all precautions listed in the operating manual and other associated documents.

2. Use designated parts only

The set's components possess important safety characteristics, such as noncombustibility and the ability to tolerate large voltages. Be sure that replacement parts possess the same safety characteristics as the originals. Also remember that the Δ mark, which appears in circuit diagrams and parts lists, denotes components that have particularly important safety functions; be extra sure to use only the designated components.

3. Always follow the original design when mounting parts and routing wires

The original layout includes various safety features, such as inclusion of insulating materials (tubes and tape) and the mounting of parts above the printer board. In addition, internal wiring has been routed and clamped so as to keep it away from hot or high-voltage parts. When mounting parts or routing wires, therefore, be sure to duplicate the original layout.

4. Inspect after completing service

After servicing, inspect to make sure that all screws, components, and wiring have been returned to their original condition. Also check the area around the repair location to ensure that repair work has caused no damage, and confirm safety.

5. When replacing chip components...

Never reuse components. Also remember that the negative side of tantalum capacitors is easily damaged by heat.

6. When handling flexible print boards...

- The temperature of the soldering-iron tip should be about 270C.
- Do not apply the tip more than three times to the same pattern.
- Handle patterns with care; never apply force.

Caution: Remember that hard disk drives are easily damaged by vibration. Always handle with care.

ATTENTION AU COMPOSANT AYANT RAPPORT À LA SÉCURITÉ!

LES COMPOSANTS IDENTIFÉS PAR UNE MARQUE Δ SUR LES DIAGRAMMES SCHÉMATIQUES ET LA LISTE DES PIÈCES SONT CRITIQUES POUR LA SÉCURITÉ DE FONCTIONNEMENT. NE REMPLACER CES COMPOSANTS QUE PAR DES PIÈSES SONY DONT LES NUMÉROS SONT DONNÉS DANS CE MANUEL OU DANS LES SUPPLÉMENTS PUBLIÉS PAR SONY.

TABLE OF CONTENTS

<u>Section</u>	<u>Title</u>	<u>Page</u>
CHAPTER 1. REMOVAL		
1-1.	Flowchart	1-1
1-2.	Main Electrical Parts Location Diagram	1-1
1-3.	Removal	1-2
1.	Hinge Cover	1-2
2.	Keyboard Unit, Palm Rest Assy, Hood Keyboard Assy, Touch Pad, CNX-125 Board, Palm Rest Plate, Bracket Pad	1-2
3.	Display Assy, Combination Drive (CD-RW/DVD-ROM)	1-3
4.	HDD Assy, DC Fan	1-3
5.	Latch Detector, PWS-13 Board	1-4
6.	PC Card Connector, Modem card, MBX-49 Board, Lithium Battery, I/O Bracket	1-4
7.	Speaker Unit, SWX-73 Board	1-5
8.	SO-DIMM	1-5
9.	Modem Card	1-6
10.	LCD Section – Made by SA –	1-7
1.	Bezel Housing Assy, LCD Unit	1-7
2.	Inverter Assy, LCD Harness, FPC, Display Housing Assy	1-8
1-4.	Replacing the CPU	1-9
1.	Removing the CPU	1-9
2.	Installing the CPU	1-9
1-5.	DIP Switch Setting of the MBX-49 Board	1-10
	(to 1-10)	
CHAPTER 2. SELF DIAGNOSTICS		
	(to 2-1)	
CHAPTER 3. BLOCK DIAGRAM		
	(to 3-2)	
CHAPTER 4. FRAME HARNESS DIAGRAM		
	(to 4-2)	
CHAPTER 5. EXPLODED VIEWS AND PARTS LIST		
5-1.	Main Section	5-1
5-1.	Main Section	5-2
5-2.	LCD Section – Made by SA –	5-5
	(to 5-6)	

- Abbreviations
- UC : US model / Canadian model

1-1. Flowchart

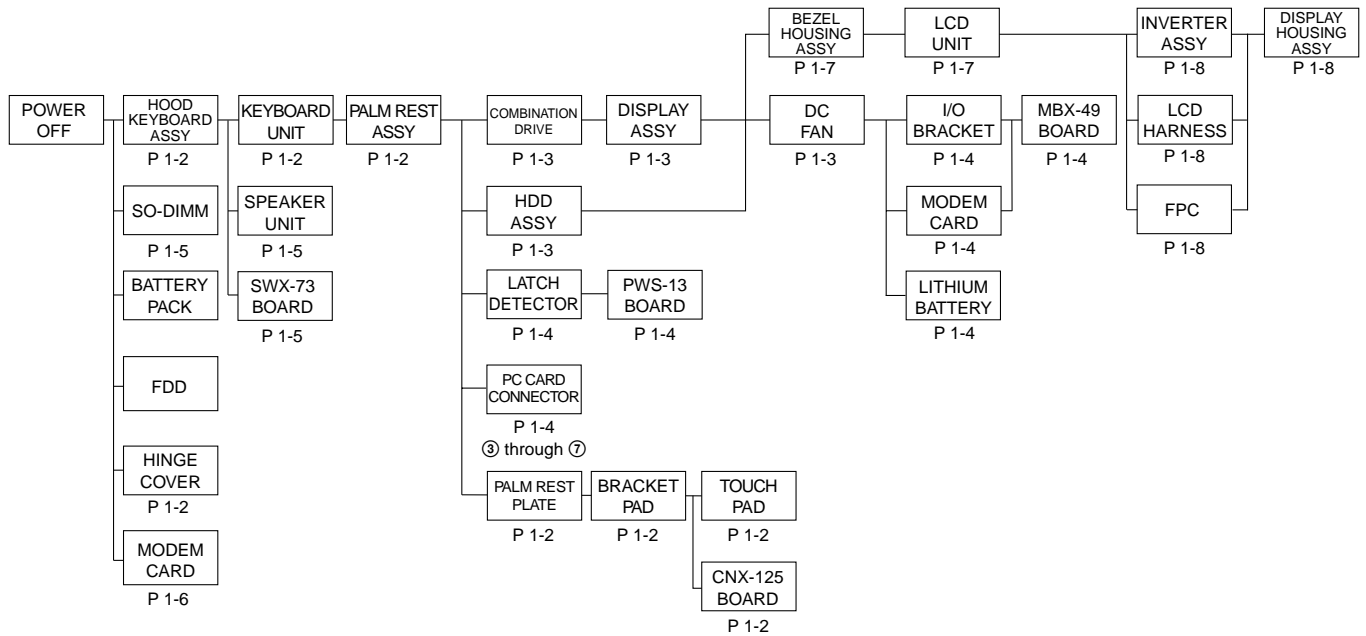

- P XX means pages that appears in this manual.
- Remember that hard disk drives are easily damaged by vibration. Always handle with care.

1-2. Main Electrical Parts Location Diagram

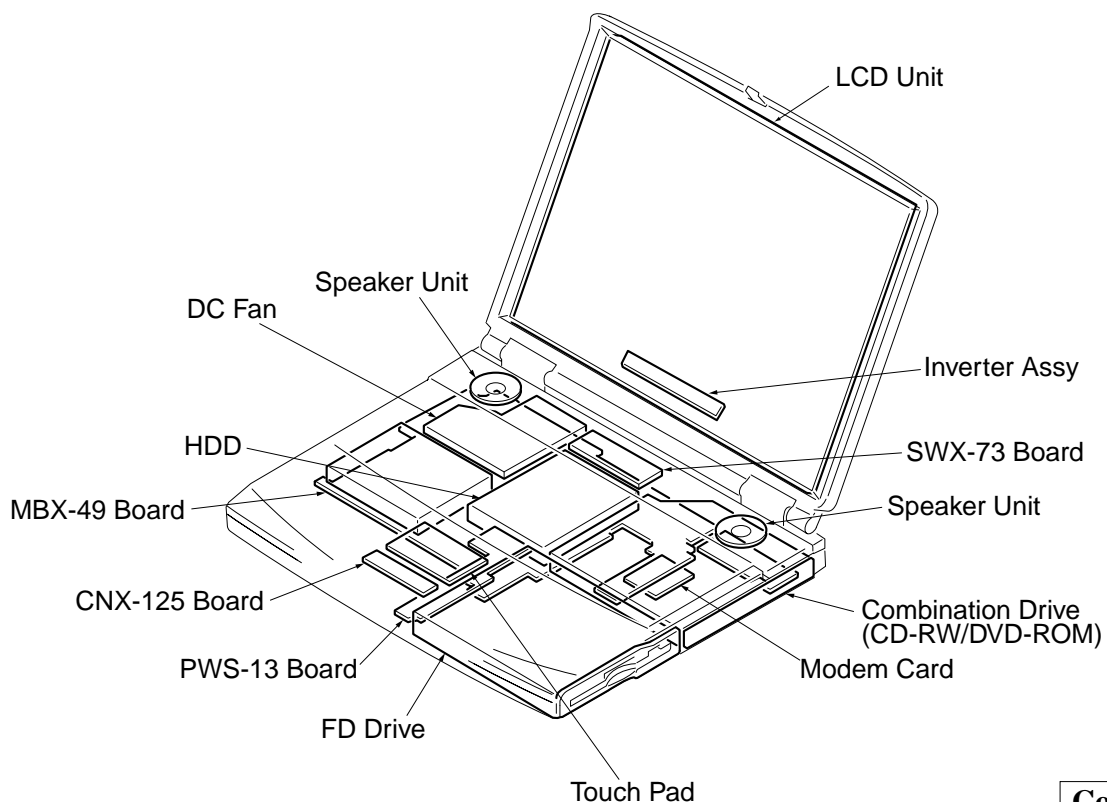

3. Display Assy, Combination Drive (CD-RW/DVD-ROM)

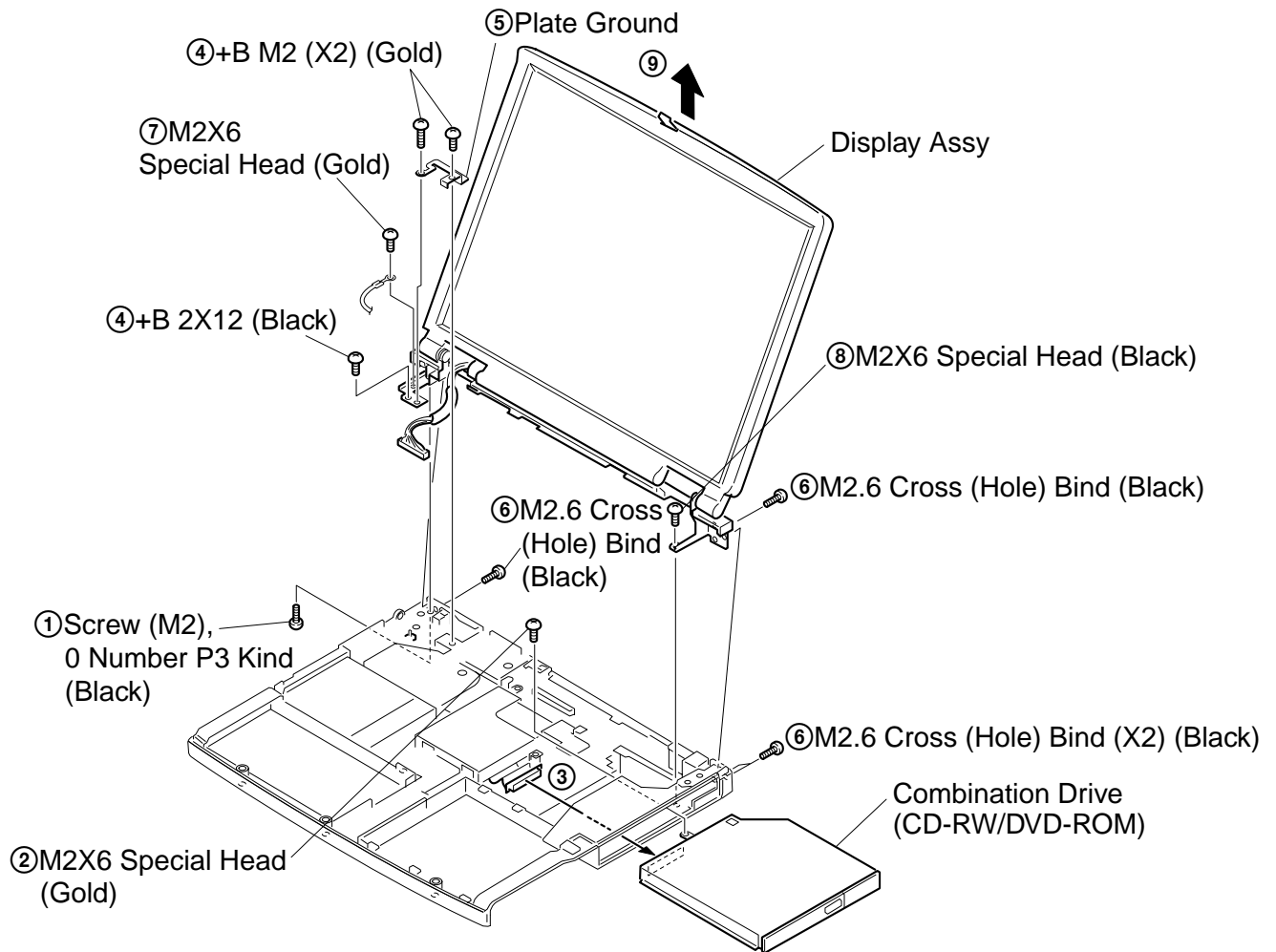

4. HDD Assy, DC Fan

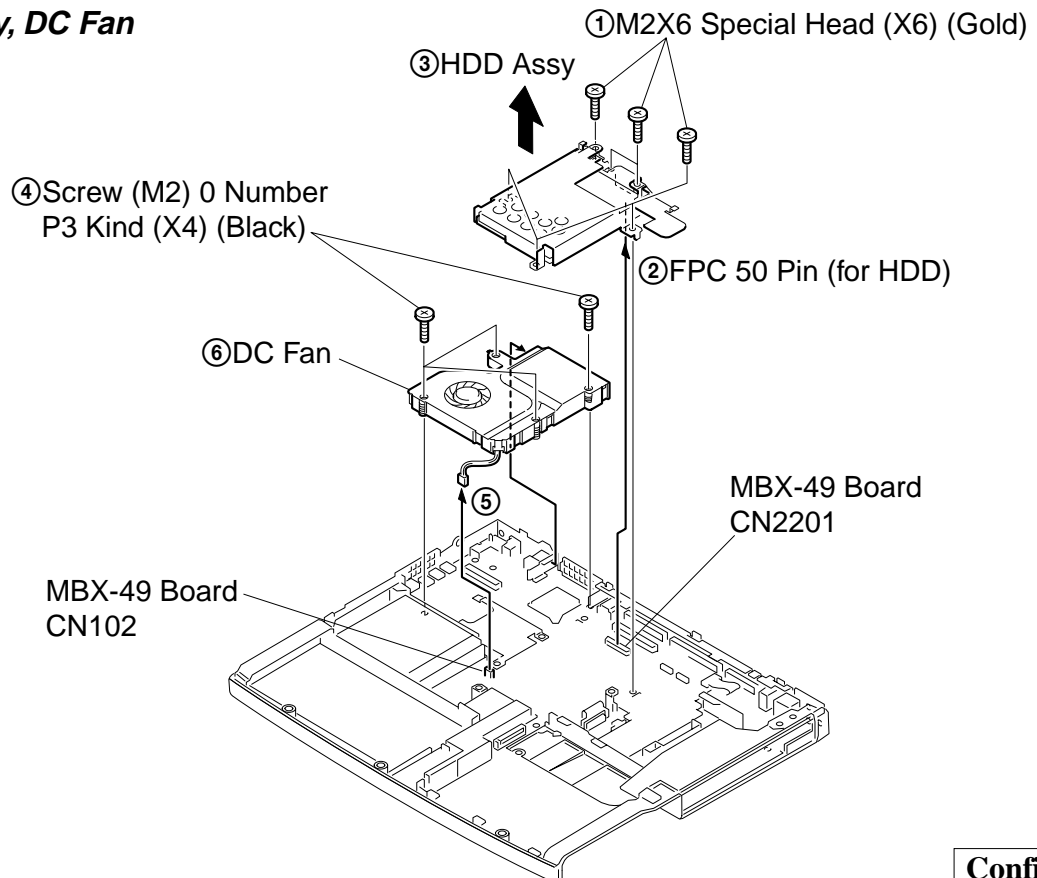

Confidential

5. Latch Detector, PWS-13 Board

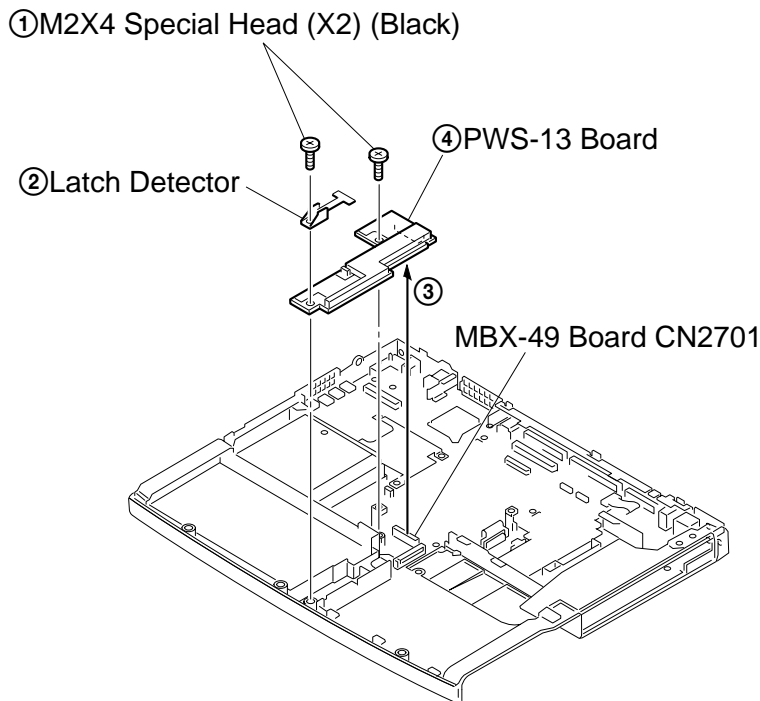

6. PC Card Connector, Modem Card, MBX-49 Board, Lithium Battery, I/O Bracket

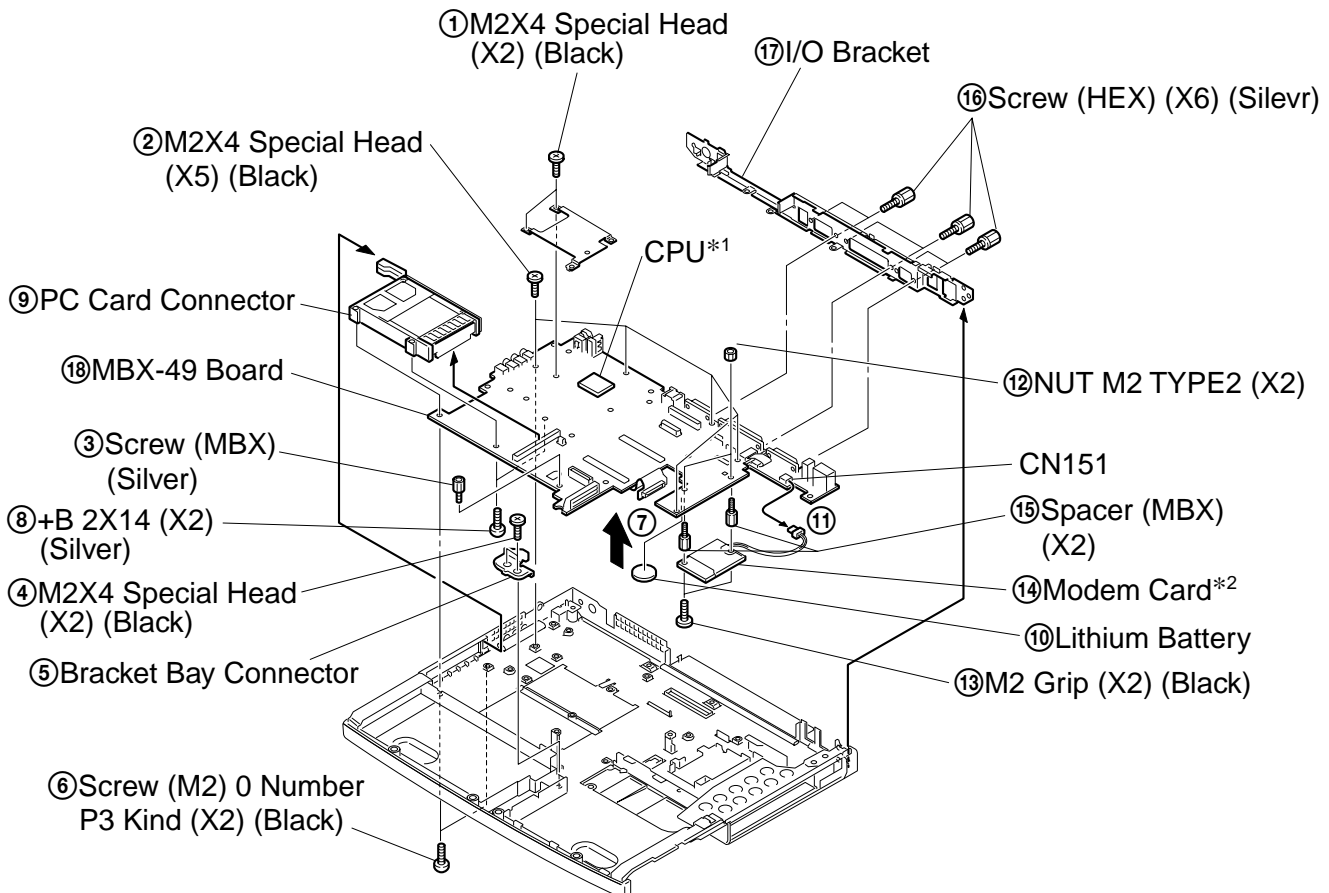

*1 When removing the CPU, refer to “ 1-4. Replacing the CPU ”.

*2 Modem card can be removed from the bottom.

Refer to the subsequent paragraph “ 9. Modem card ” for more details.

Confidential

7. Speaker Unit, SWX-73 Board

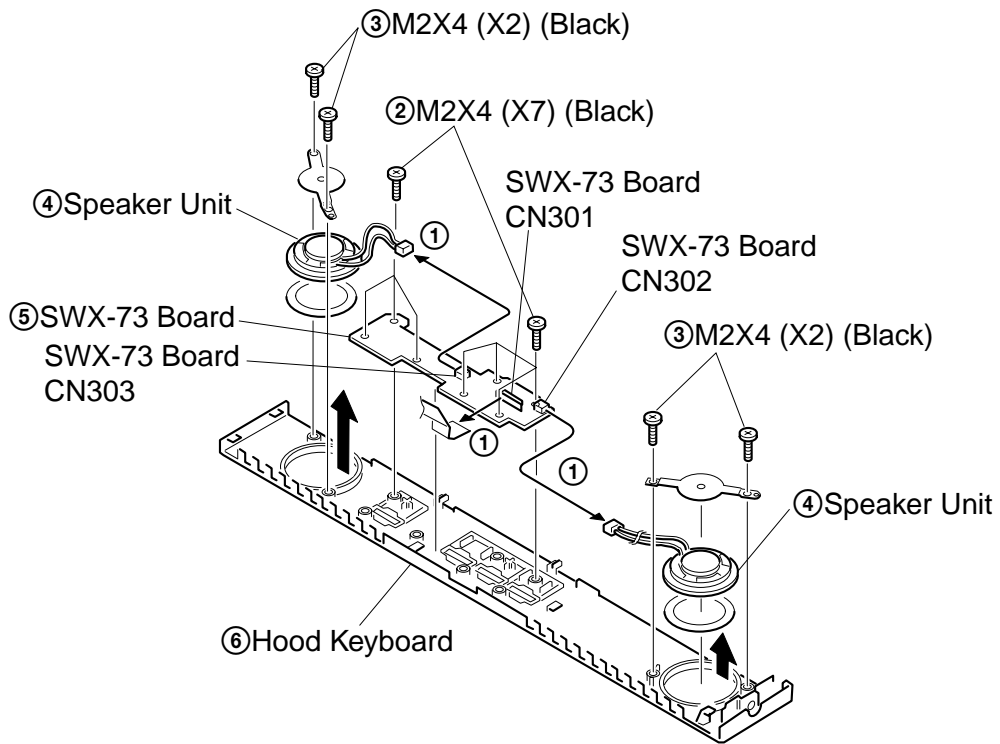

8. SO-DIMM

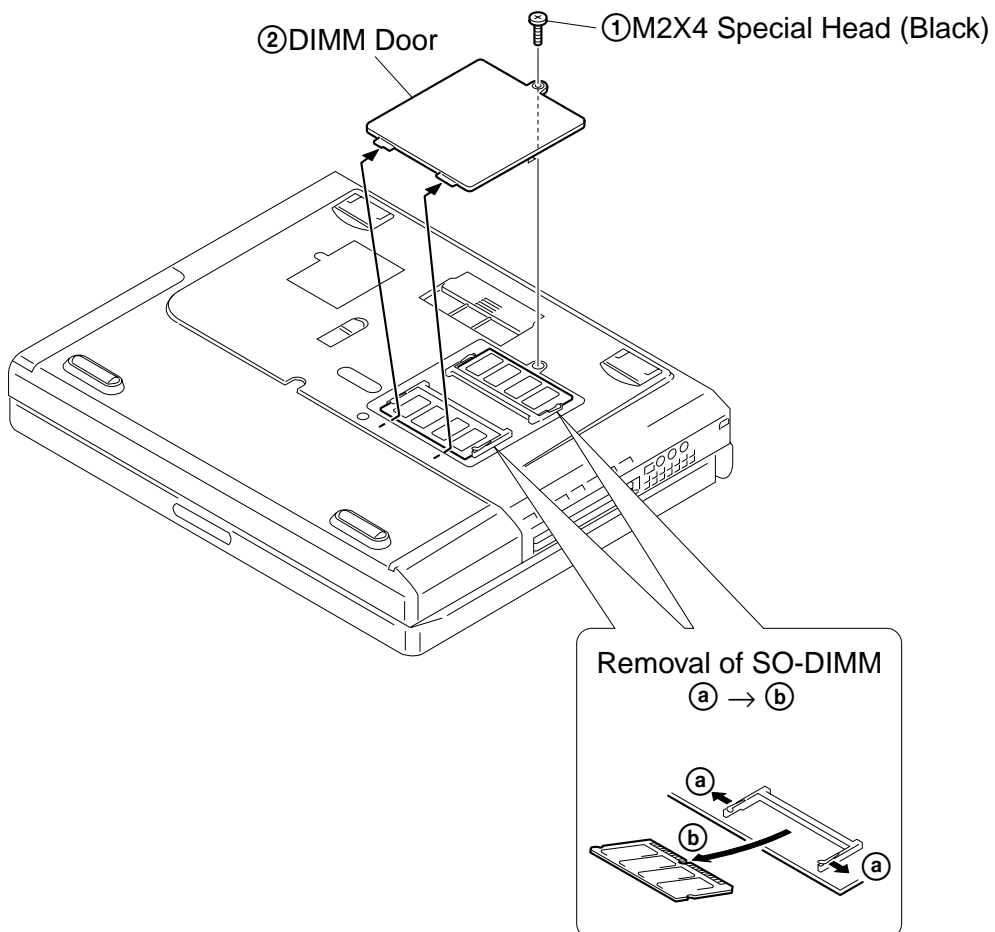

9. Modem Card

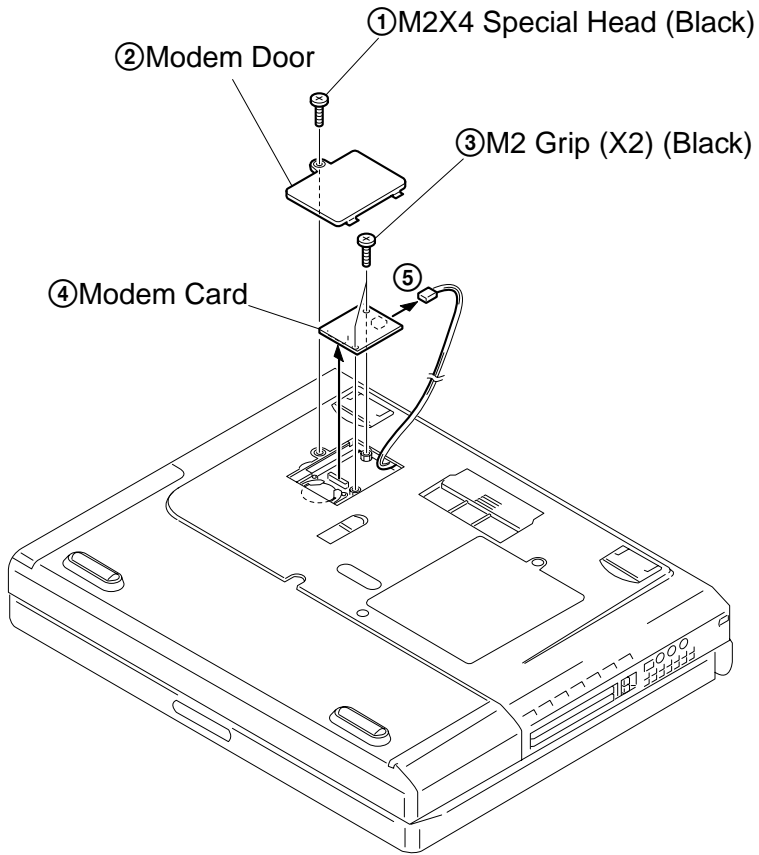

10. LCD Section – Made by SA –
1. Bezel Housing Assy, LCD Unit

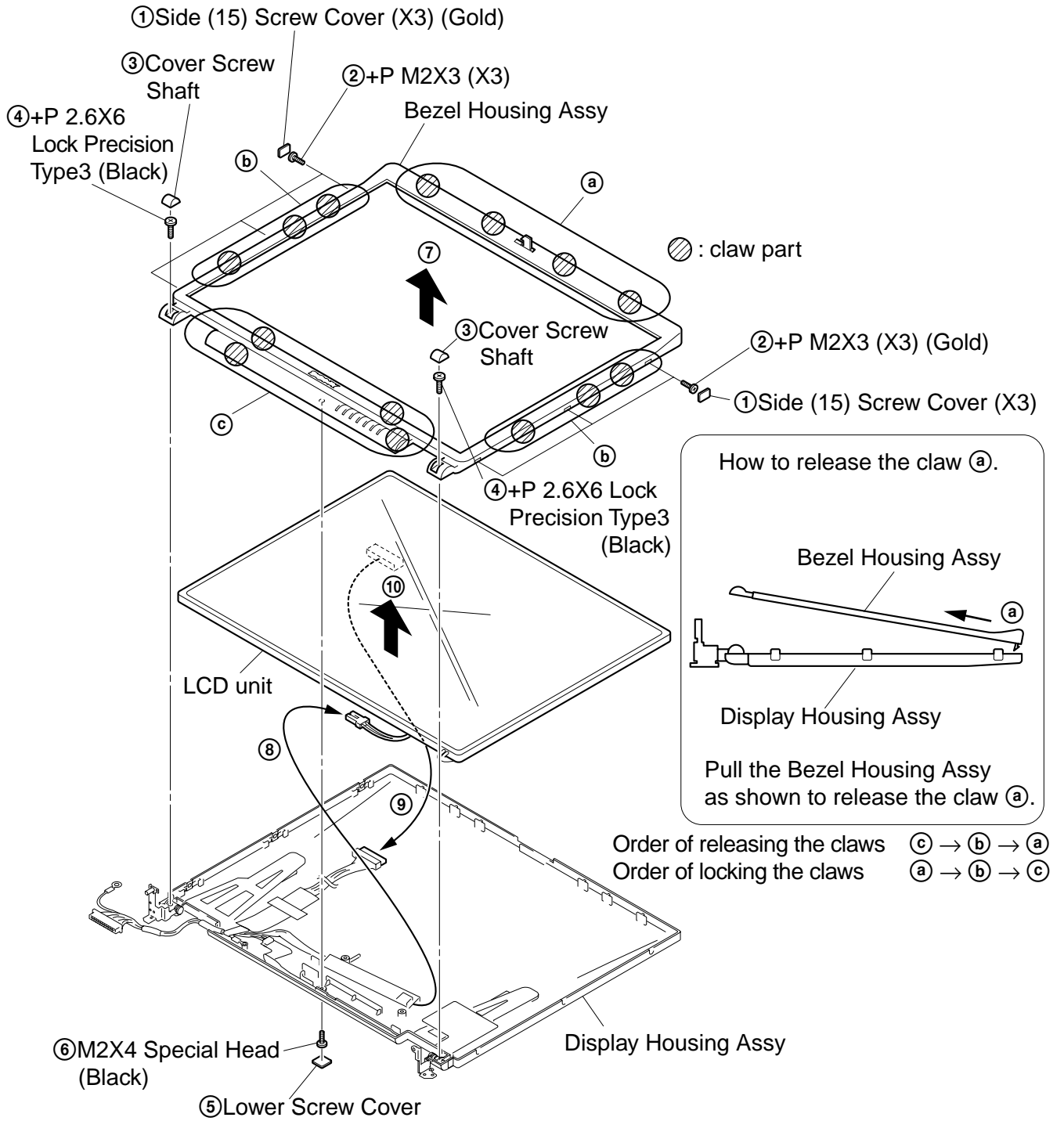

Confidential

2. Inverter Assy, LCD Harness, FPC, Display Housing Assy

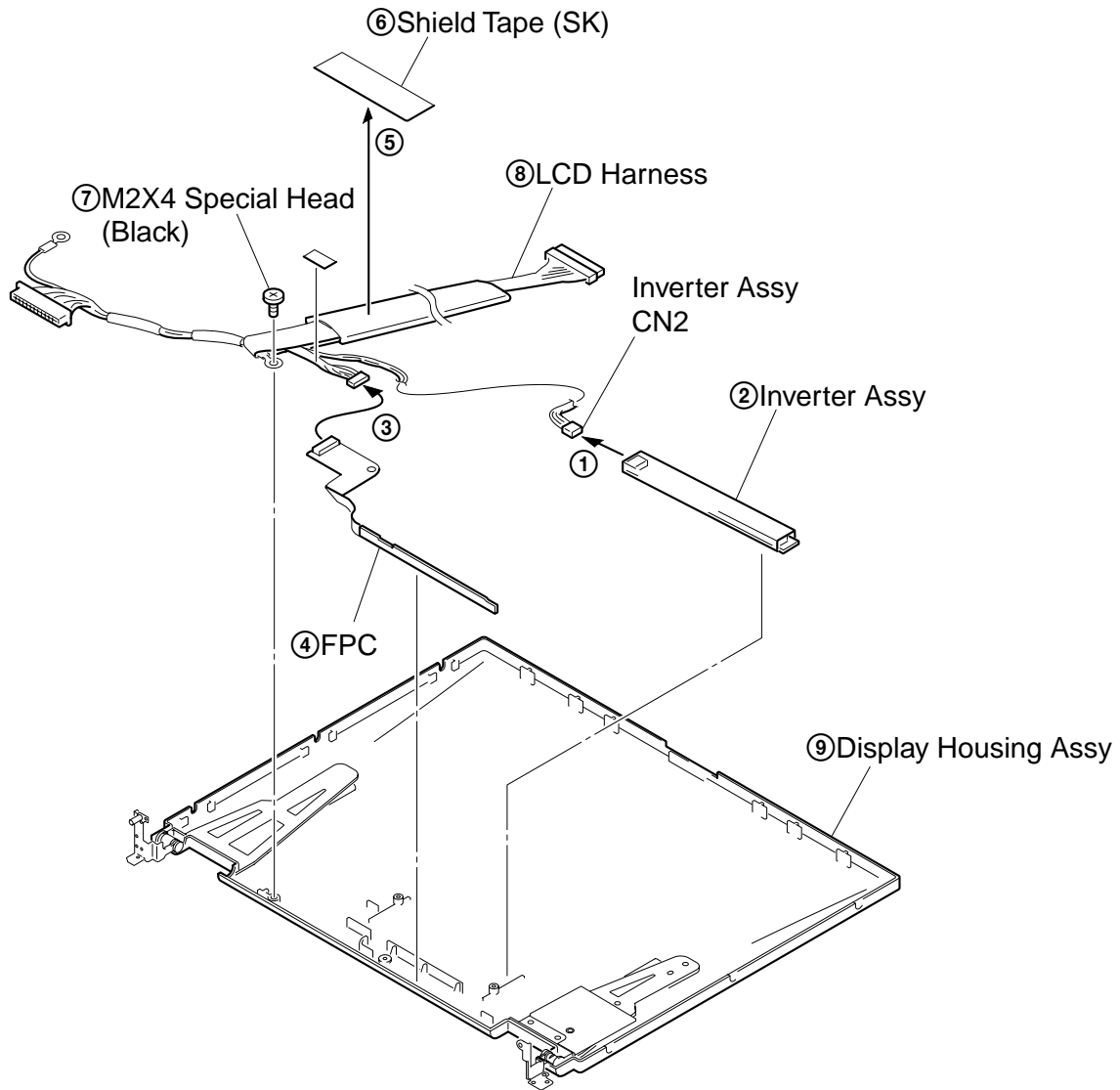

1-4.Replacing the CPU

1. Removing the CPU

- ① Insert a flat-blade screwdriver into the notch as shown in the illustration and rotate it so that the protrusion comes to the lock release position.
- ② Pull the CPU gently upward to lift it out of the CPU socket.

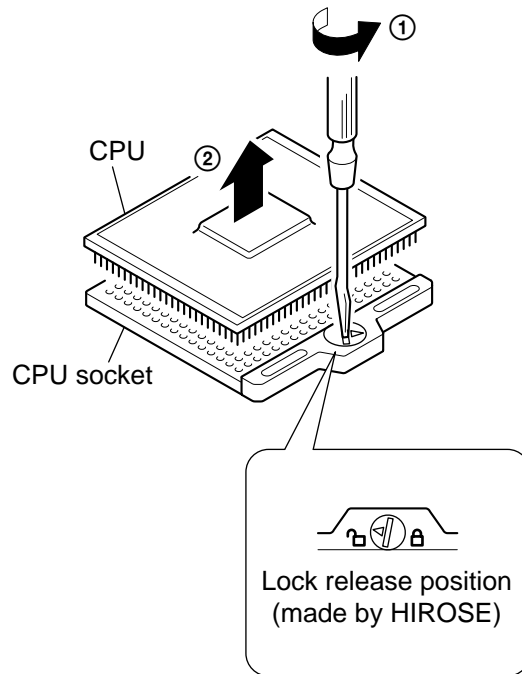

2. Installing the CPU

- ① Align the triangle reference mark of the CPU with that of the CPU socket and insert all the pins of the CPU to the corresponding holes of the CPU socket.
- ② Insert a flat-blade screwdriver into the notch as shown in the illustration and rotate it so that the protrusion comes to the lock position.

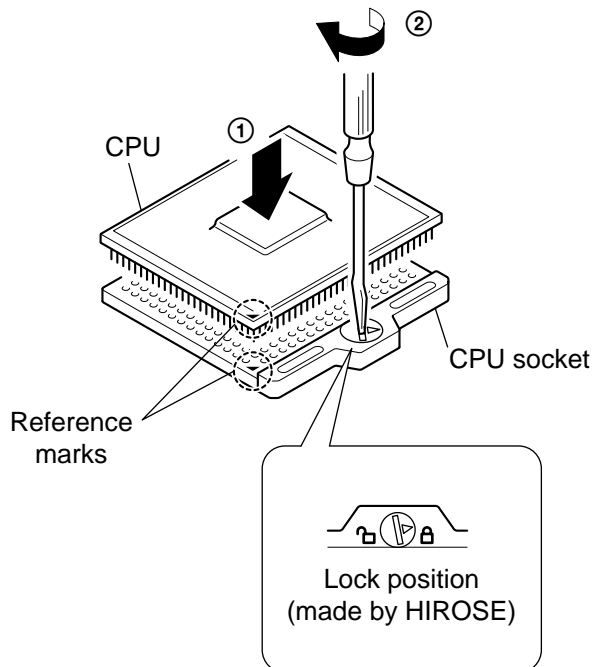

NOTE:

Rotate a flat-blade screwdriver to the lock position securely. If not, the operation of the CPU may become unstable.

1-5. DIP Switch Setting of the MBX-49 Board

The DIP switch on the MBX-49 board (main board) is set to match with the LCD that is used in this computer.

Part No.	DIP switch setting																		
1-476-576-11	<div data-bbox="507 465 778 613" style="text-align: center;"> </div> <p data-bbox="434 640 884 721">The upper position where ON indication is shown is the ON position . The lower position is the OFF position.</p> <table border="1" data-bbox="443 743 861 819"> <thead> <tr> <th>No.</th> <th>1</th> <th>2</th> <th>3</th> <th>4</th> <th>5</th> <th>6</th> <th>7</th> <th>8</th> </tr> </thead> <tbody> <tr> <td>ON/OFF</td> <td>1</td> <td>0</td> <td>0</td> <td>1</td> <td>0</td> <td>1</td> <td>1</td> <td>1</td> </tr> </tbody> </table> <p data-bbox="683 824 858 855" style="text-align: center;">0 : ON 1 : OFF</p>	No.	1	2	3	4	5	6	7	8	ON/OFF	1	0	0	1	0	1	1	1
No.	1	2	3	4	5	6	7	8											
ON/OFF	1	0	0	1	0	1	1	1											

CHAPTER 2.

SELF DIAGNOSTICS

ATTENTION

Please confirm “Self Diagnostics” method which will be informed you with distribution of “Self Diagnostics” software.

CHAPTER 4. FRAME HARNESS DIAGRAM

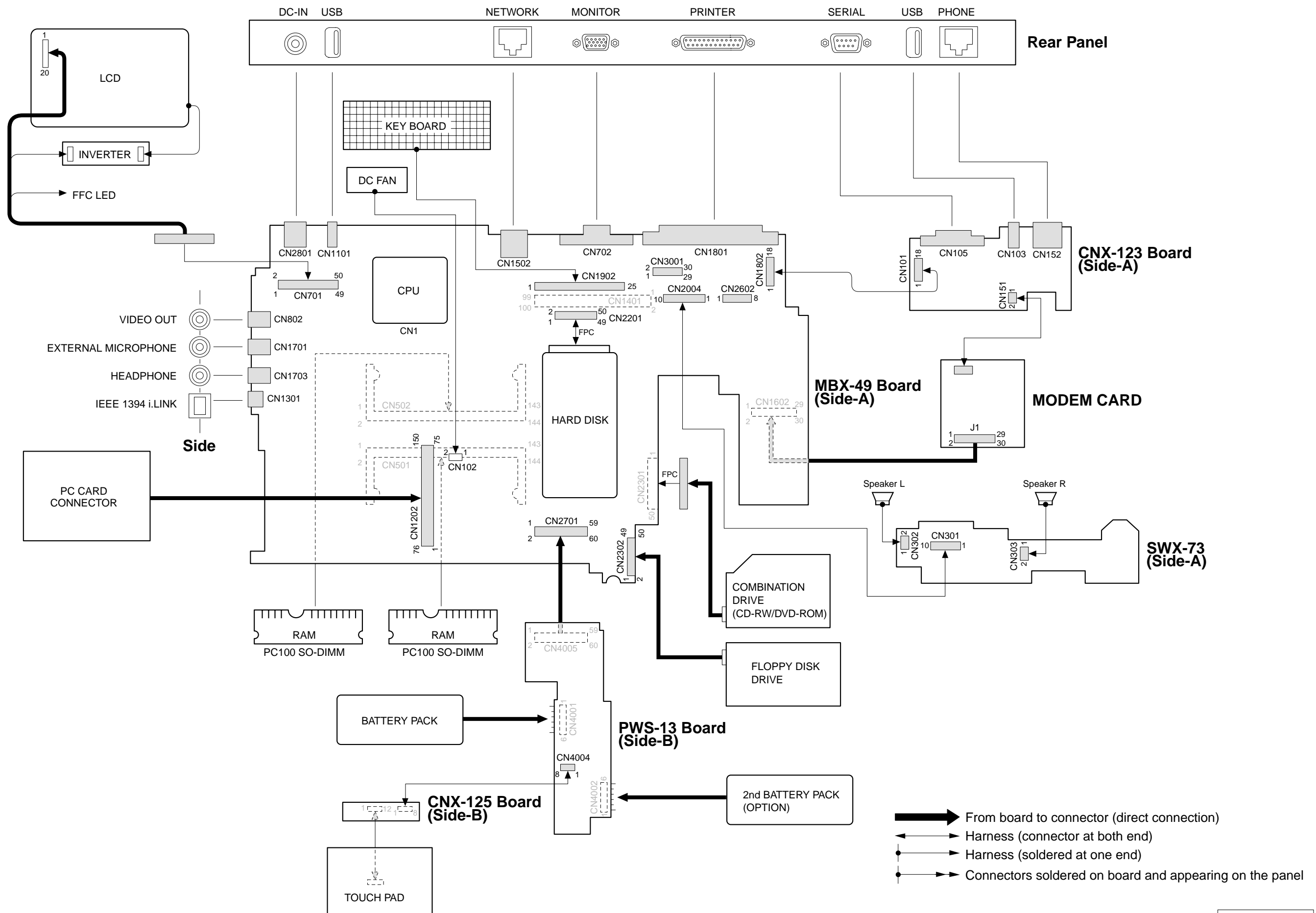

- From board to connector (direct connection)
- ↔** Harness (connector at both end)
- Harness (soldered at one end)
- ⋯→** Connectors soldered on board and appearing on the panel

EXPLODED VIEWS AND PARTS LIST

NOTE:

- The mechanical parts with no reference number in the exploded views are not supplied.
- Items marked “ * ” are not stocked since they are seldom required for routine service. Some delay should be anticipated when ordering these items.
- When two or more parts are shown in parallel, use the part described first as the main part.

The components identified by mark Δ or dotted line with mark Δ are critical for safety. Replace only with part number specified.

Les composants identifiés par une marque Δ sont critiques pour la sécurité. Ne les remplacer que par une pièce portant le numéro spécifié.

5-1. Main Section

Ref.No.	Part No.	Description	Ref.No.	Part No.	Description
1	X-4623-411-1	ASSY BOTTOM (AM)	139	A-8048-964-A	ASSY BAY FD (CZ)
3	4-640-837-22	DOOR BATTERY	147	8-759-835-93	IC KP80526GY001256 (PIII 1GHz)
* 8	4-651-706-01	HEATSINK BOTTOM	148	X-4623-561-2	ASSY LATCH DETECTOR
* 11	4-651-707-21	INSULATOR HEATSINK BOTTOM	* 152	4-651-871-01	HEAT SINK
12	1-763-658-11	FAN, DC (WITH HEAT SINK)	153	4-652-012-01	SHEET, ELECTRIC HEAT
15	4-643-832-21	DUMMY CARD	154	4-651-989-01	SPACER (MBX)
18	A-8066-543-A	COMPLETE PWB SWX-73 (PPK)	155	4-651-701-01	DOOR MODEM
19	X-4623-388-2	ASSY HOOD KEYBOARD Z	156	4-653-151-01	SPACER (KBF)
20	1-529-287-11	SPEAKER UNIT	157	4-653-466-01	CUSHION (HD-M)
21	3-718-233-01	NUT, PLATE	159	4-653-963-01	SHIELD (CNX)
22	1-790-639-22	FPC 50PIN (FOR HDD)	160	4-653-964-01	SPACER (B/P)
24	1-772-936-11	HDD (30.0GB)-DJSA230	161	4-654-019-01	GASKET (AV)
25	1-476-647-11	KEY BOARD UNIT (US)	162	4-654-047-01	SHIELD (AV)
26	X-4623-390-1	ASSY PALMREST	163	4-653-936-01	GASKET (HB/M)
27	1-772-529-72	PAD, TOUCH	164	4-654-320-41	SHEET (COIL), THERMAL
28	A-8066-540-A	COMPLETE PWB CNX-125	165	4-654-350-01	SHEET (CPU), THERMAL
* 29	4-651-699-01	BRACKET PAD	166	1-779-745-21	JACK, DC
* 30	4-651-708-22	BRACKET (HDD)	167	1-815-422-11	USB CONNECTOR (VERTICAL)
* 31	4-640-861-11	BRACKET CD-ROM R	168	1-695-514-21	JACK (SMALL TYPE) 1P
32	1-796-072-11	COMBO DRIVE (UJDA710)	169	1-815-221-21	CONNECTOR, USB (VERTICAL)
33	X-4623-442-1	ASSY DOOR DVD-RW PA (EXP)	170	4-653-962-01	SHIELD (USB)
* 34	4-640-860-12	BRACKET (CD-ROM L)	B1	4-641-726-41	SCREW (M2), SPECIAL HEAD
35	4-640-828-01	PLATE FDD	B3	4-644-899-01	SCREW (M2), 0 NUMBER P3 KIND
36	1-772-978-21	FDD UNIT	B4	4-639-112-01	SCREW M2X4
37	X-4623-528-1	ASSY BOTTOM FDD Z (TCY2)	B6	4-646-807-01	0 PLATE M2.5 (FDD)
38	4-651-713-01	DOOR I/O	B7	4-644-402-12	SCREW (MBX)
39	4-651-844-01	FOOT REAR	B8	4-641-726-11	SCREW (M2), SPECIAL HEAD
40	4-651-714-01	DOOR DOCKING CONNECTOR	B10	4-652-498-01	+B M2 (NOJI)
41	4-640-851-11	FOOT FRONT	B12	4-645-177-01	SCREW (M1.7X3.5)
46	A-8066-576-A	COMPLETE PWB PWS-13 (2ND)	B14	4-645-497-01	SCREW (M2.6), CROSS (HOLE) BIND
48	1-761-380-22	CARD, MODEM	B15	4-635-301-01	SCREW M3X4
52	1-790-640-11	FPC 50PIN (FOR CD-ROM)	B17	7-622-205-05	NUT M2 TYPE2
53	1-790-641-11	FPC 50PIN (FOR FDD)	B18	4-635-966-01	SCREW (HEX)
55	4-640-845-11	BUTTON BAY	B19	7-621-772-70	SCREW +B 2X14
56	4-644-349-01	LATCH BAY	B29	4-646-807-11	0 PLATE M2.5 (FDD)
* 57	4-640-854-01	SPRING BAY	B31	4-645-214-11	GRIP, M2
* 58	4-651-850-01	BRACKET BOTTOM	B32	7-621-772-68	SCREW +B 2X12
* 59	4-640-857-01	DOOR BATTERY SPRING	B33	4-642-852-21	+B M2
60	4-651-698-01	DISPLAY BASE			
63	4-651-928-01	COVER BATTERY CONNECTOR			
67	4-652-099-02	LABEL I/O			
68	4-641-629-01	INSULATOR FDD			
69	4-641-763-21	LABEL FD			
* 71	4-641-851-02	SPRING (FDD), PLATE			
* 72	4-651-709-01	BRACKET IO			
74	4-651-702-01	DOOR DIMM			
* 76	4-644-361-01	BRACKET SPK			
* 78	4-644-362-11	PLATE PALMREST			
81	8-749-019-00	IC HYM71V16M655AT6-P (PC-100 SO-DIMM (128MB CL2))			
84	1-960-827-21	HARNESS (2 PIN)			
88	A-8066-832-A	MBX49 (1G) ASSY (S)			
105	4-641-630-11	COVER BAY HOLE			
112	1-815-505-12	CONNECTOR, 2 SLOT CARD BUS			
123	1-790-711-21	FFC (PPK)			
124	1-757-767-11	FFC (TP-CNX)			
125	1-790-710-11	FFC (SWX-PWS)			
126	4-644-053-01	SPACER FDD			
* 128	4-653-452-01	PLATE, GROUND			
* 134	4-645-433-01	BRACKET BAY CONNECTOR			
136	4-644-357-01	CUSHION SPK			

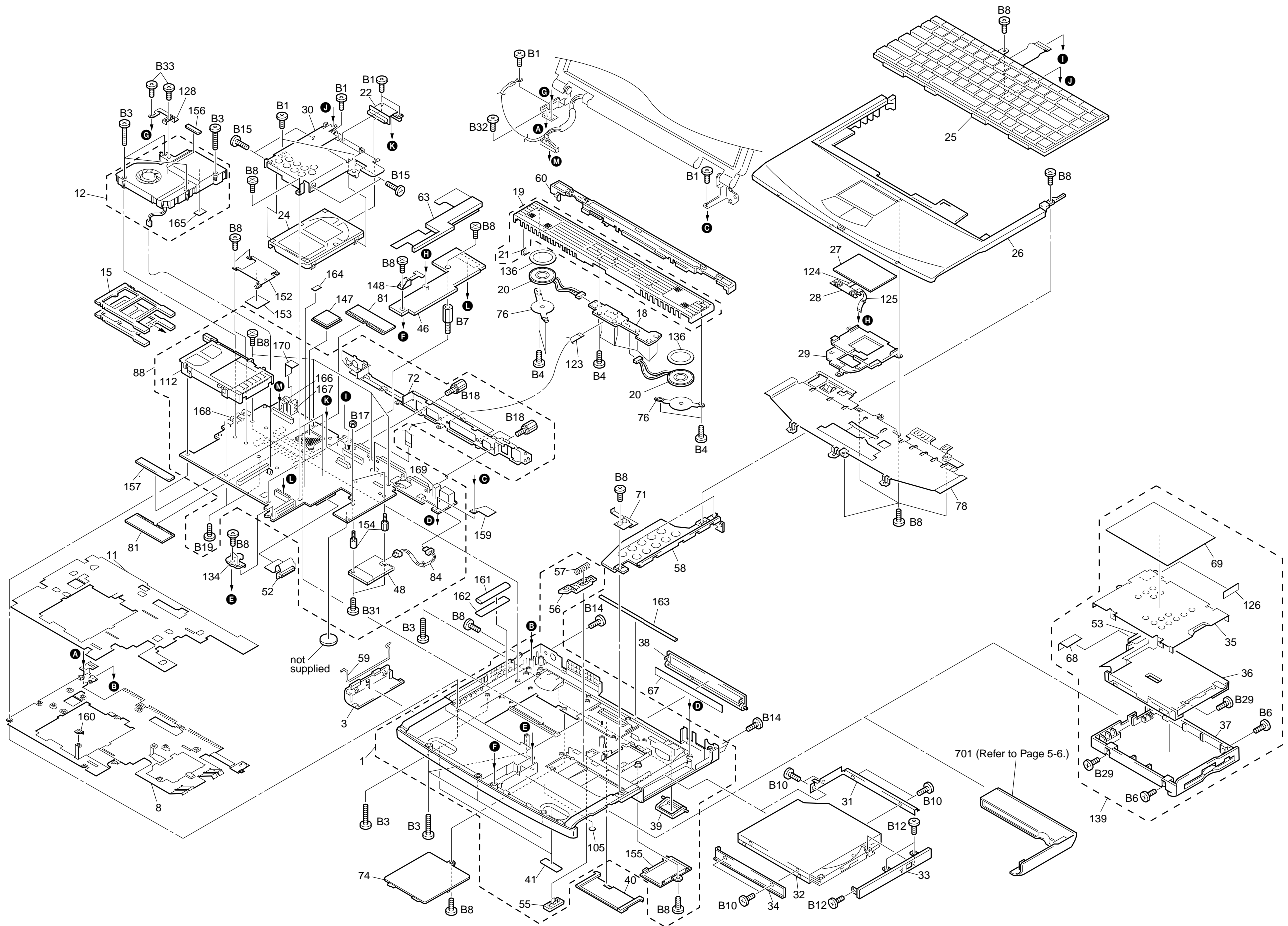

5-2. LCD Section – Made by SA –

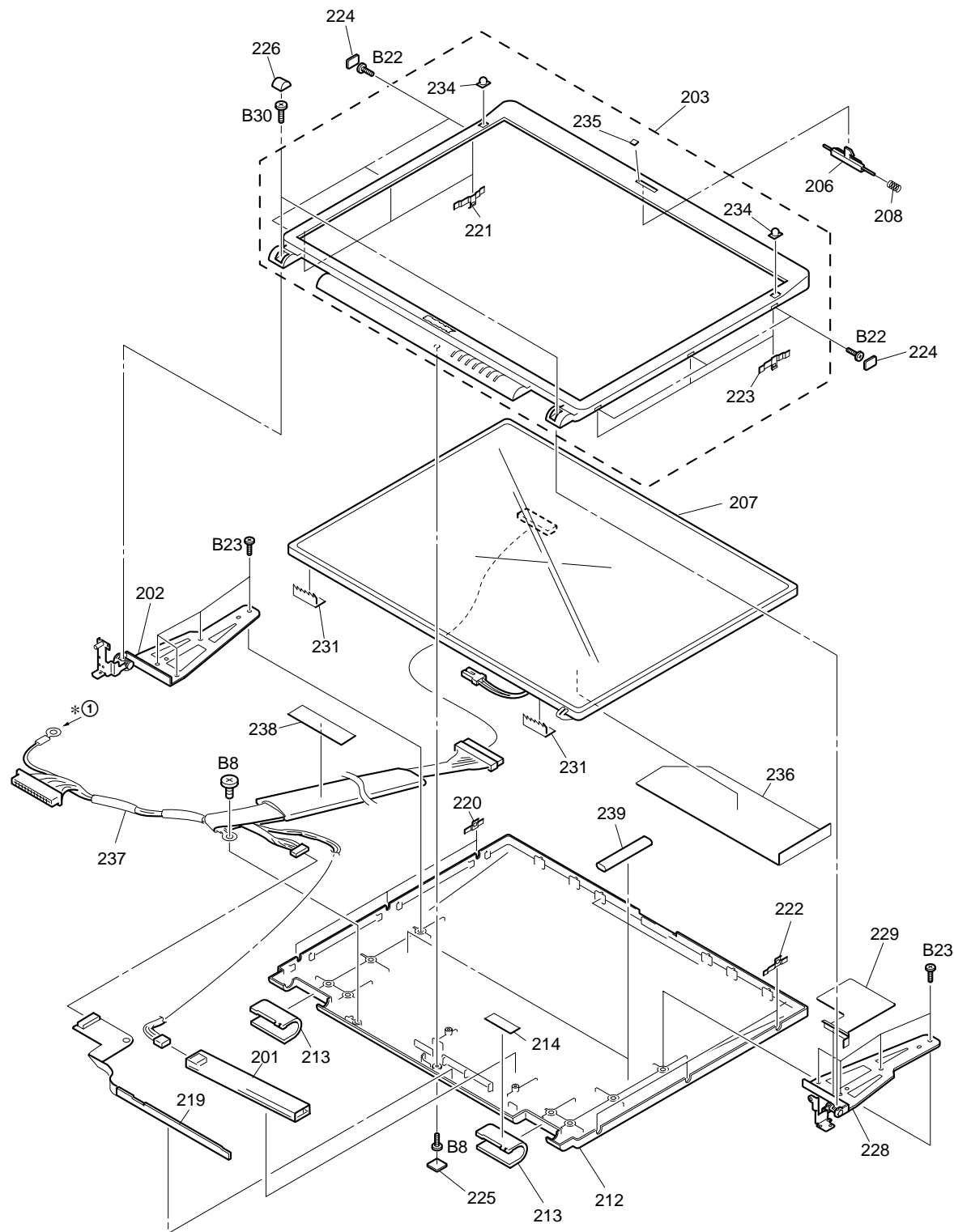

*① For the installation position, refer to page 5-3.

Ref.No.	Part No.	Description
201	1-476-316-11	INVERTER UNIT
202	X-4623-380-1	HINGE LEFT 15
203	X-4623-446-2	ASSY HOU, BEZEL 15SA-Z (EXP)
206	4-637-902-41	LATCH
207	1-476-576-11	LCD-UNIT (15.0 TFT-SXGA+)
208	4-637-903-01	SPRING LATCH
212	X-4623-415-1	ASSY HOU, DISPLAY 15SA-Z
213	4-642-762-41	COVER HINGE (15)
214	4-653-704-31	(FX290)...LABEL ID (U)
214	4-653-704-41	(FX290K)...LABEL ID (U)
219	1-757-604-11	PWB, FLEXIBLE PRINT (SINGLE)
220	4-642-755-01	BRACKET LCD (DL) 15
221	4-642-756-01	BRACKET LCD (BL) 15
222	4-642-757-01	BRACKET LCD (DR) 15
223	4-642-758-01	BRACKET LCD (BR) 15
224	4-646-217-11	COVER SCREW SIDE (15)
225	4-635-277-22	COVER SCREW LOWER
226	4-643-549-12	COVER SCREW SHAFT
228	X-4623-381-1	HINGE RIGHT 15
229	4-643-366-11	EDGE GUARD HINGE (15)
231	4-643-837-01	SHIELD (LCD)
234	4-635-276-22	COVER SCREW UPPER
235	4-642-760-12	CUSHION CENTER
236	4-646-216-01	SHIELD TAPE (LCD) L
237	1-961-017-21	HARNESS, LCD (SXGA+)
238	4-650-831-01	SHIELD TAPE (SK)
239	4-653-980-01	GASKET HINGE (15)
B8	4-641-726-11	SCREW (M2), SPECIAL HEAD
B22	4-642-761-01	+P M2X3 LOCK
B23	4-644-165-01	SCREW (M2.6X4), 0 PLATE P1 MAIN
B30	4-643-550-01	+P 2.6X6 LOCK PRECISION TYPE3

NOTE :

The dip switch on the MBX-49 board (Main board) is set to match with the LCD (1-476-576-11) that is used in this computer.

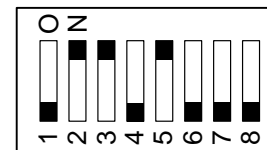

The upper position where ON indication is shown is the ON position . The lower position is the OFF position.

No.	1	2	3	4	5	6	7	8
ON/OFF	1	0	0	1	0	1	1	1

0 : ON 1: OFF

Ref.No.	Part No.	Description
ACCESSORIES *****		
701	A-8048-965-A	ASSY WEIGHT SAVER (Z) (Refer to Page 5-4.)
△ 702	1-476-342-12	ADAPTOR, AC
703	1-528-935-13	PACK, LITHIUM ION BATTERY
704	1-575-875-51	CORD, CONNECTION
△ 1-757-562-21		CORD, POWER
4-654-839-11		QUICK START, FX290, FX290K

701
Weight saver (1)

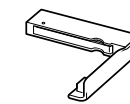

703
Battery pack (1)

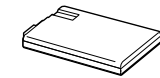

702
AC adaptor (1)

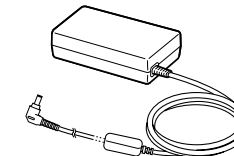

704
Video cable (1)

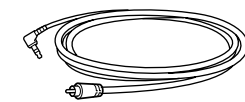

The components identified by mark △ or dotted line with mark △ are critical for safety. Replace only with part number specified.

Les composants identifiés par une marque △ sont critiques pour la sécurité. Ne les remplacer que par une pièce portant le numéro spécifié.



PCG-FX290/FX290K (UC)

This manual and the constituent data may not be replicated, copied nor reprinted in whole or in part without prior written authorization of Sony Corporation.