

18	346671600015	INSULATOR;PCMCIA,8175	1		
17	346671700006	INSULATOR;CD-ROM,M-B,8575	1		
16	346671700016	AL-FOIL;HDD,M/B,8575	1		
15	345671700004	GASKET;USB,8575	1		
14	345671700003	THERMAL PAD;SIS301,8575	1		
13	346671750002	INSULATOR;MINIPCI,ID3,8575A	1		
12	421668300005	WIRE ASSY;BIOS,BATTERY,HOPE	1		
11	411671750011	PWA;PWA-8575A,MOTHER R00 BD,T/U	1		
10	411671700006	PWA;PWA-8575,D/D BD R0A,T/U	1		
9	375120262008	NUT-HEX;M2.6, NCG	3		
8	375102030010	NUT-HEX;M2,2, NIW	2		
7	370102010606	SPC-SCREW;M2L6,K-HD(+0.2),NIB/NLK	6		
6	346671700001	INSULATOR;AL-FOIL,M/B BOTTOM,8575	1		
5	346671200036	INSULATOR,MDC,8170	1		
4	344600000824	IC CARD CON PART;68P,IC1ISA-BD-PEJR	1		
3	341668300008	STANDOFF;MDC MODEM,NLK,HOPE	2		
2	340671700006	HEATSINK ASSY;N/B,8575	1		
1	340671200014	SCREW ASSY;IC,82845,8170	3		
NO.	PART NO.	DESCRIPTION	Q'TY	VENDOR	REMARK

										DATE	18-Jul-02	MATERIAL	SEE NOTES	TREATMENT	REMARK
										UNIT	MM	SCALE	0.350	DRAWING NAME	PWA;PWA-8575A,MOTHER R00 BD
										DRAWN	DESIGNED	CHECKED	APPROVED	MATERIAL NO.	AD 411671750010 R00
										MITAC International Corp.					
ITEM	CONTENTS OF CHANGE	CHK	APV	MM/DD/YY	SHEET NO. 1 OF 1										

MODEL : 8575 A

Revision 01

Contexts

Title	Page
COVER SHEET & SCREW HOLE	1
System Block Diagram	2
Power Block Diagram	3
P4-CPU (1/2)	4
P4-CPU (2/2)	5
SIS650(1/3)	6
SIS650(2/3)	7
SIS650(3/3)	8
TV/LVDS ENCODER(SIS301LV)	9
LCD/VGA INTERFACE & LEDs	10
MAIN CLOCK & CLOCK BUFFER	11
DDR SODIMMs	12
DDR TERMINATION	13
SIS961(1/3)	14
SIS961(2/3)	15
SIS961(3/3)	16
IDE INETRFACE	17
PCI 1410 / PU2211	18
LAN PHY (ICS 1893) & MDC	19
AUDIO CODEC & AUDIO AMP	20
SUPER I/O, T/P & BUTTON	21
MICROCONTROLLER (H8)	22
BATTERY CONNECT AND +1.25V	23
2.5v_DDR / +1.8VS	24
CHARGER	25
CPU CORE	26
D/D CONNECTOR	27
MINI PCI SLOT	28
NEC UPD72872 IEEE1394	29
Revision	30

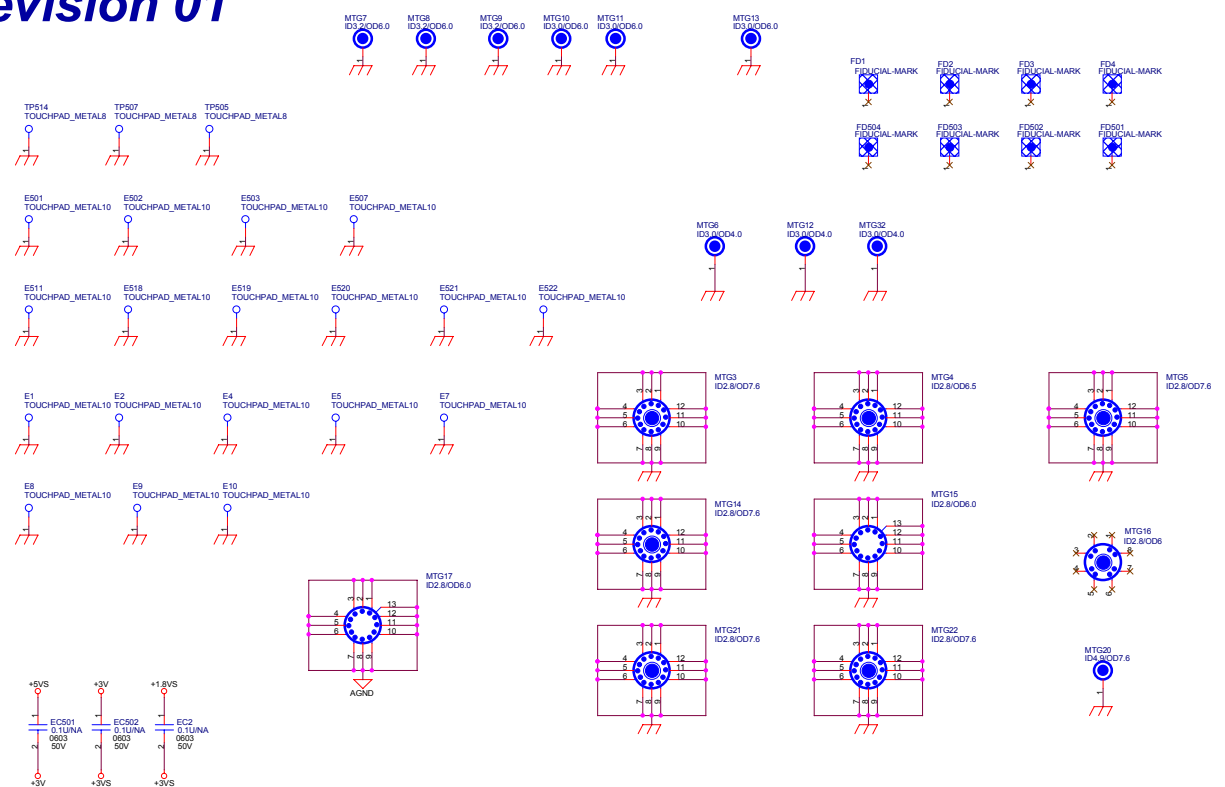

POWER STATES

STATE	VOTAGE	FULL ON	STR	STD	MEC-OFF	REMARK
-SUSB	-	HIGH	LOW	LOW	LOW	
-SUSC	-	HIGH	HIGH	LOW	LOW	
ADP	+19V	0	0	0	0	
BATTERY	+12V	0	0	0	0	
+VCC_RTC	+3.3V	0	0	0	0	
+VCC_CORE	+1.75V	0	0	X	X	
+1.8VS	+1.8V	0	X	X	X	
+1.8V	+1.8V	0	0	X	X	
+2.5V_DDR	+2.5V	0	0	X	X	
+3VS	+3.3V	0	X	X	X	
+3V	+3.3V	0	0	X	X	
+3VA	+3.3V	0	0	0	0	
+5VS	+5V	0	X	X	X	
+5V	+5V	0	0	X	X	
+5VA	+5V	0	0	0	0	
+12VS	+12V	0	X	X	X	
+12V	+12V	0	0	X	X	

IDSEL

IDSEL	CHIP
AD20	TI1410
AD22	1394 (UPD72872)

BUS MASTER

REQ/GNT	CHIP
-REQ0/-GNT0	TI1410
-REQ1/-GNT1	1394 (UPD72872)

PCIINT

PCIINT	CHIP
INTA#	SIS 650
INTB#	PCMCIA (TI1410)
INTC#	1394 (UPD72872)

DRAW	DESIGN	CHECK	ISSUED

8575 A System Block Diagram

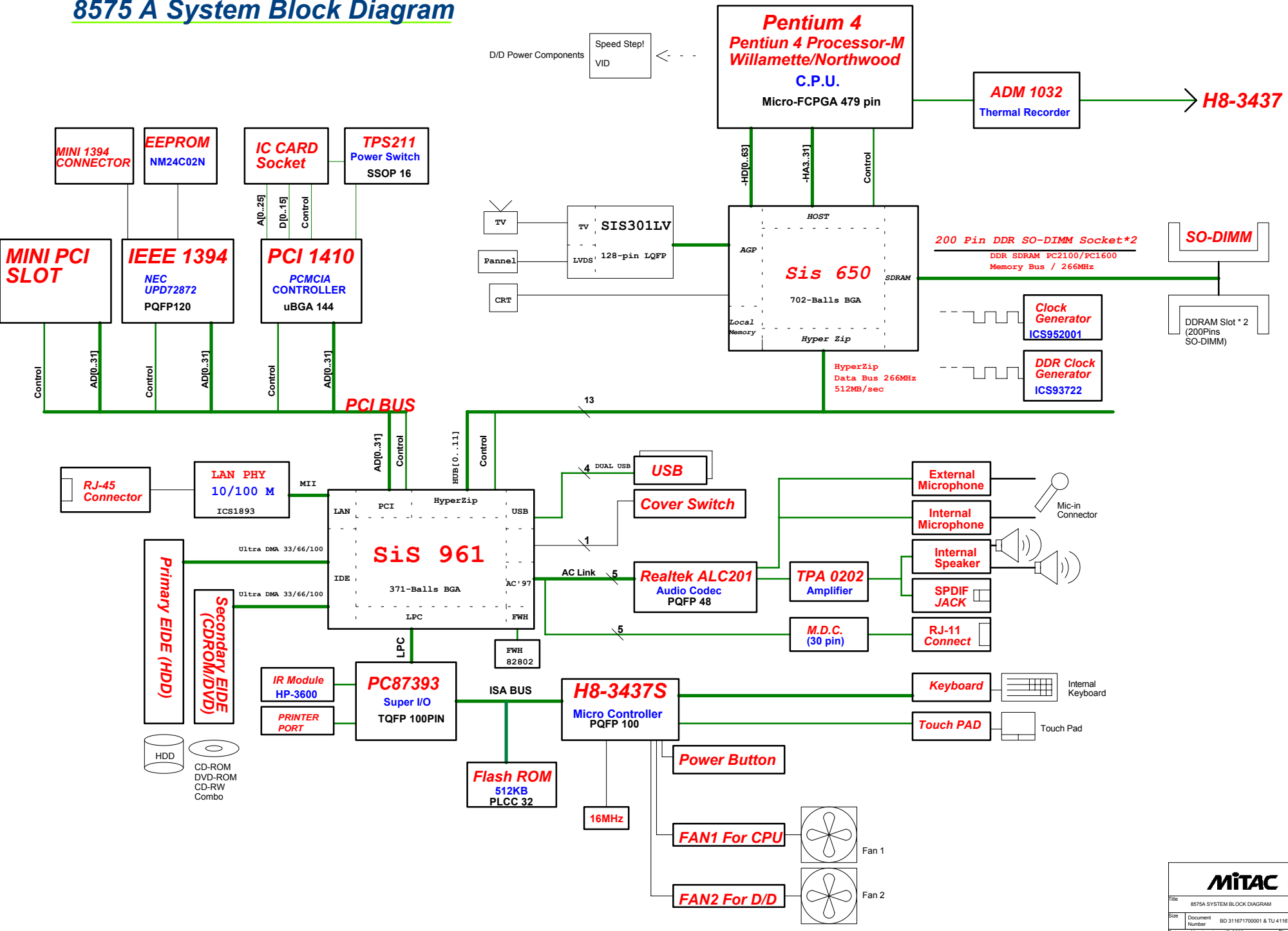

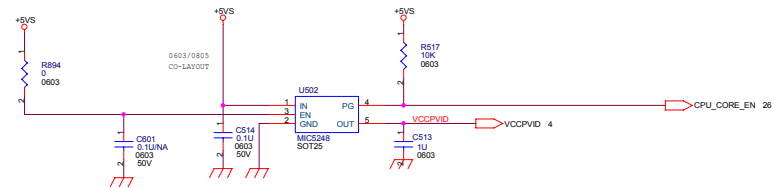
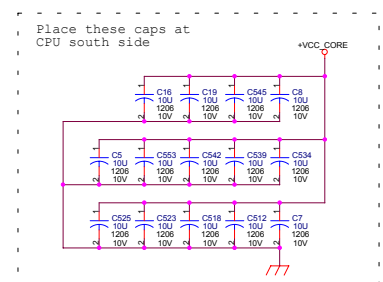
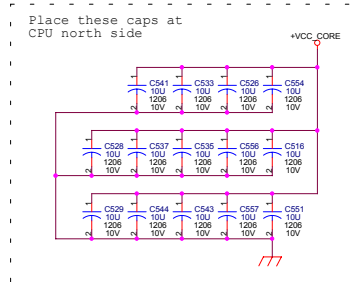
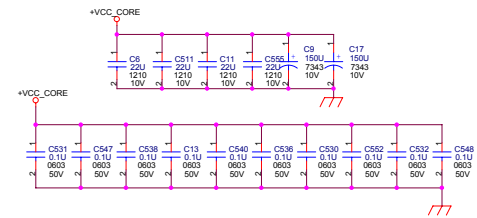
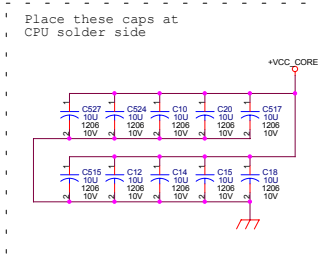
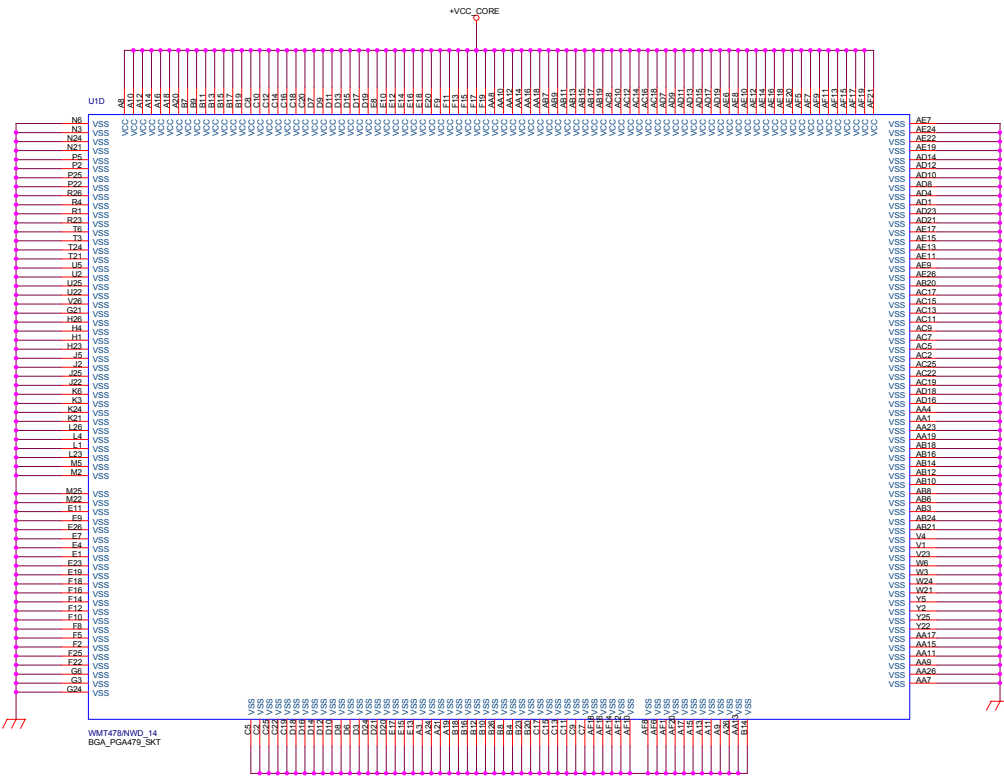

SIS650(2/3)

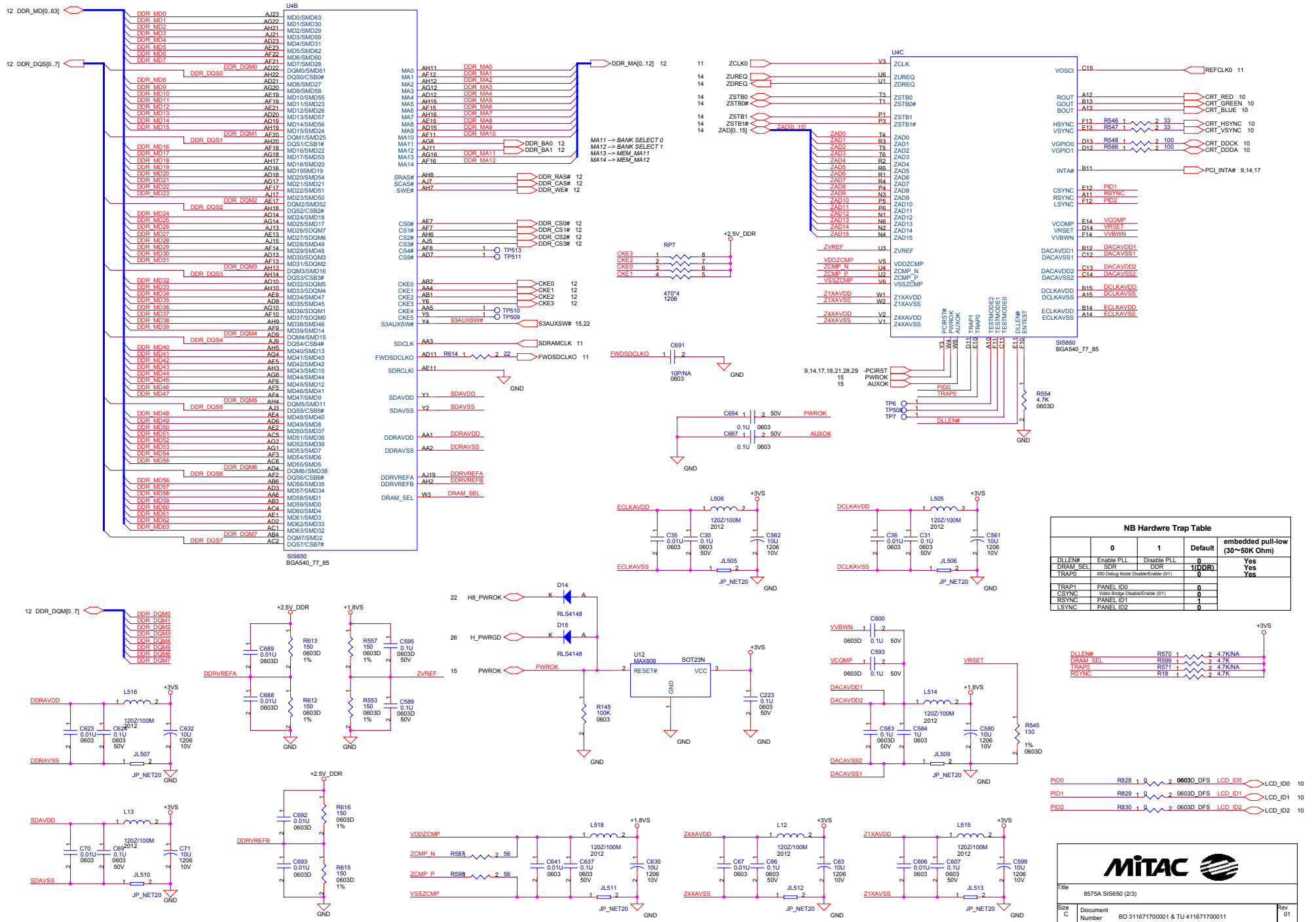

	0	1	Default	embedded pull-low (30~50K Ohm)
DILEN#	Enable PLL	Disable PLL	0	Yes
DRAM_SEL	SDR	DDR	1(DDR)	Yes
TRAP0	660 Debug Mode Disable/Enable (g1)		0	Yes
TRAP1	PANEL ID0		0	
CSYNC	Video Bridge Disable/Enable (D1)		0	
RSYNC	PANEL ID1		0	
LSYNC	PANEL ID2		0	

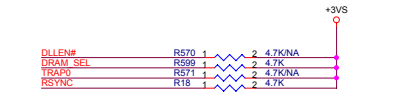

MITAC

Title: 8575A SIS650 (2/3)

Size: C

Document Number: BD 311671700001 & TU 411671700011

Date: Monday, June 17, 2002

Sheet: 7 of 30

SIS650(3/3)

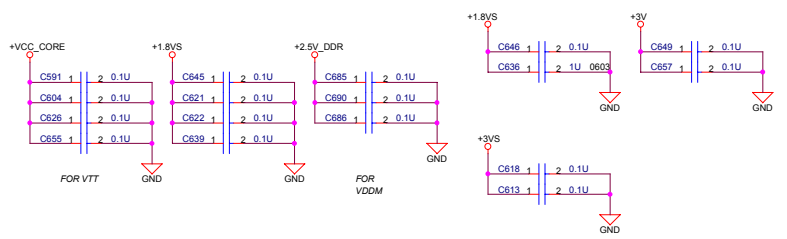
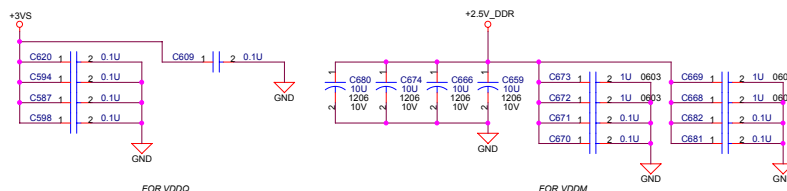
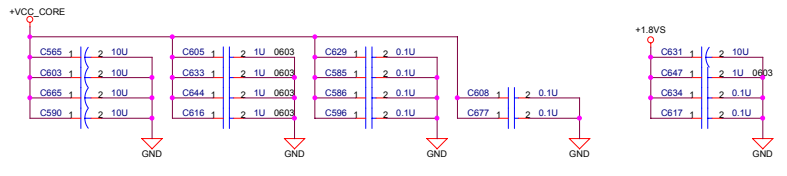
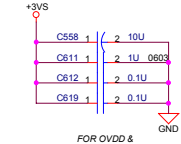
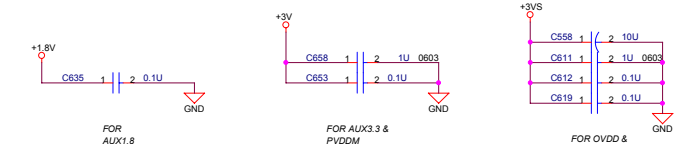
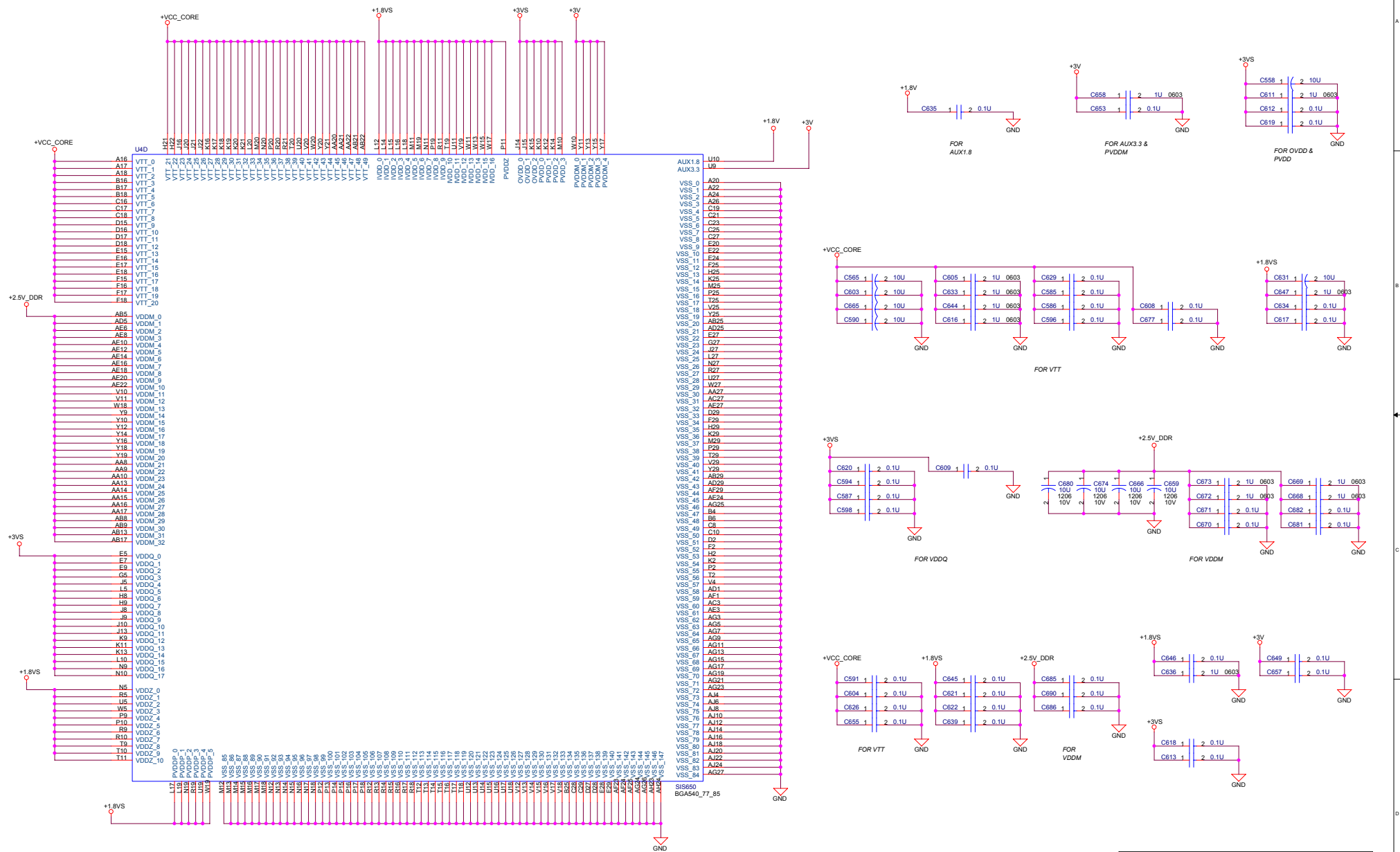

MITAC		
Title 8575A SIS650 (3/3)		
Size C	Document Number BD 311671700001 & TU 411671700011	Rev 01
Date: Monday, June 17, 2002	Sheet 8	of 30

SiS301LV/CH7019

Spread Range Selection

FS0	SR0	Spreading Range	Input Frequency	Modulation Rate
1	0	+/- 1.50%	10 MHz to 20 MHz	(Fin/10)*20.83 KHz
1	1	+/- 2.50%	10 MHz to 20 MHz	(Fin/10)*20.83 KHz
0	0	+/- 1.25%	20 MHz to 35 MHz	(Fin/10)*20.83 KHz
0	1	+/- 2.00%	20 MHz to 35 MHz	(Fin/10)*20.83 KHz

FS0 and SR0 HAVE
INTERNAL
PULL_UP 100K
Ohm

SiS301LV/ Chrontel CH7019

	SiS301LV	CH7019	
01	R40	NA	75 ohm
02	R51	NA	4.7K ohm
03	R55	NA	0 ohm
04	R59	0 ohm	NA
05	R60	0 ohm	10K ohm
06	R63	NA	10K ohm
07	R76	0 ohm	NA
08	R79	0 ohm	NA
09	R248	0 ohm	NA
10	R541	NA	0 ohm
11	R542	0 ohm	NA
12	R549	147 ohm	140 ohm
13	R550	6.04K ohm	2.4K ohm
14	R586	0 ohm	10K ohm
15	R588	NA	10K ohm
16	R589	0 ohm	NA
17	R597	0 ohm	NA
18	R598	NA	0 ohm
19	R600	0 ohm	NA
20	R602	0 ohm	NA
21	R603	0 ohm	NA
22	R834	NA	75 ohm
23	R835	2K ohm	NA
24	C32	NA	0.1u
25	C72	NA	0.1u
26	C307	0.1u	NA
27	C887	0.1u	NA
28	C888	1u	NA
29	R604	NA	0 ohm
30	R601	0 ohm	NA
31	R111	NA	10K ohm
		PAGE 06	
32	R45	NA	22 ohm
33	R23	22 ohm	NA
34	R19	0 ohm	NA
35	R22	0 ohm	NA
36	R108	NA	0 ohm
37	R110	NA	0 ohm
38	R34	NA	22 ohm

	VGA	YUV TV	SCART	Normal TV
GPIOA	0	0	1	1
GPIOB	0	1	0	1

	GPIOC	GIPOD	Normal TV	Normal TV
GPIOC	0	0	1	1
GIPOD	0	1	0	1
Normal TV	Normal	PAL-M	PAL-N	Normal
YUV TV	525I	525P	750P	1080I

MITAC

Title: 8575A TV/LVDS ENCODER (SiS301LV)

Size C Document BD 31167170001 & TU 41167170011 Rev 01

Number Date: Monday, June 17, 2002 Sheet 9 of 30

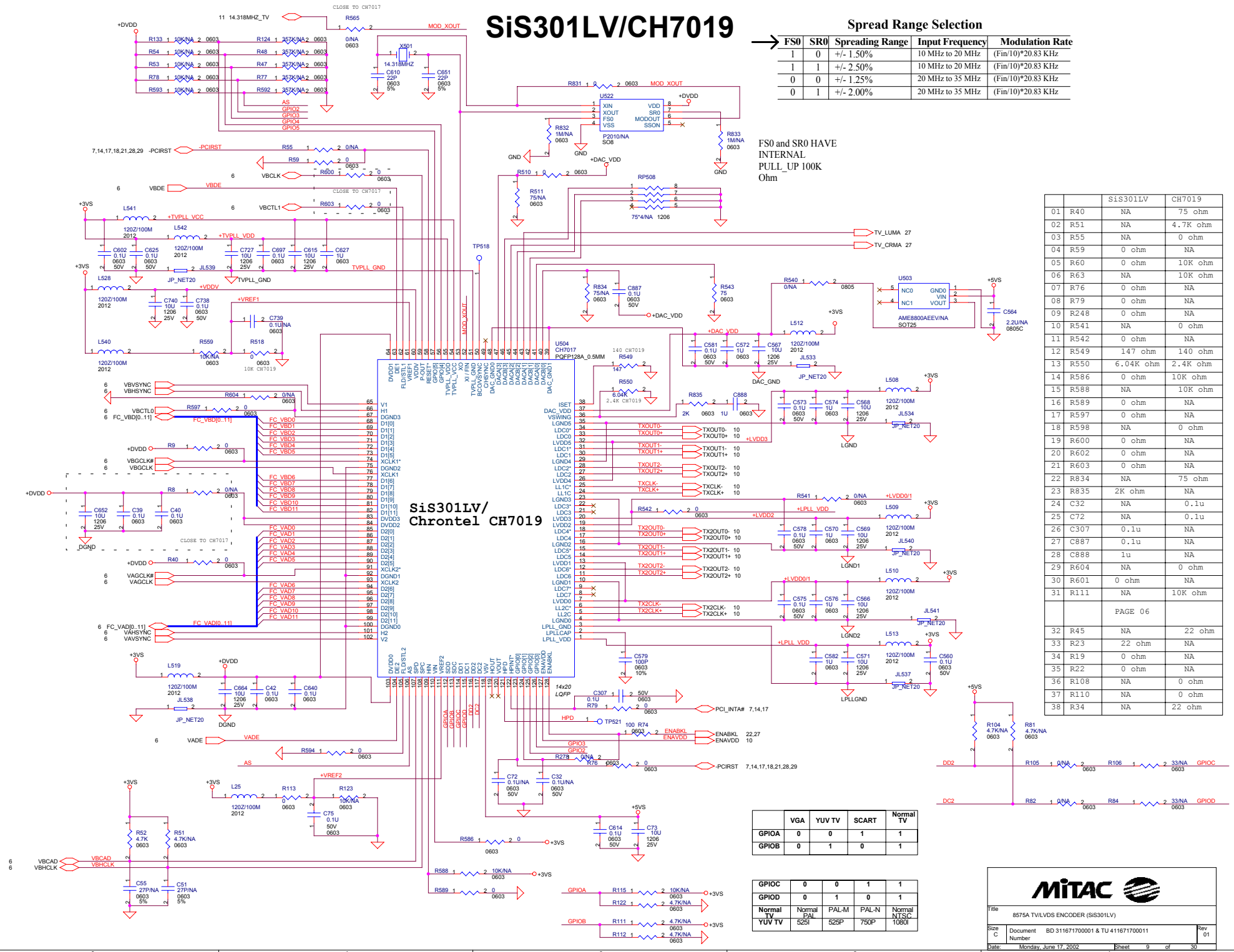

LCD & CRT INTERFACE

LED INDICATOR

D16	D15	D13	D14	D15
CDROM	HDD	NUM	CAP	SCROLL

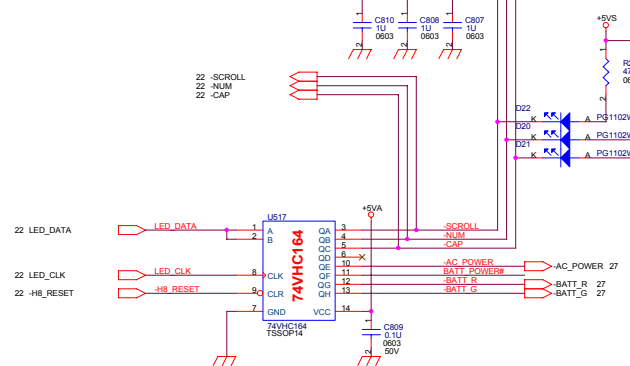

(NA D10, D8, D9, D11, D15, R586, R211, R212, R213, R96, For LCD 15")

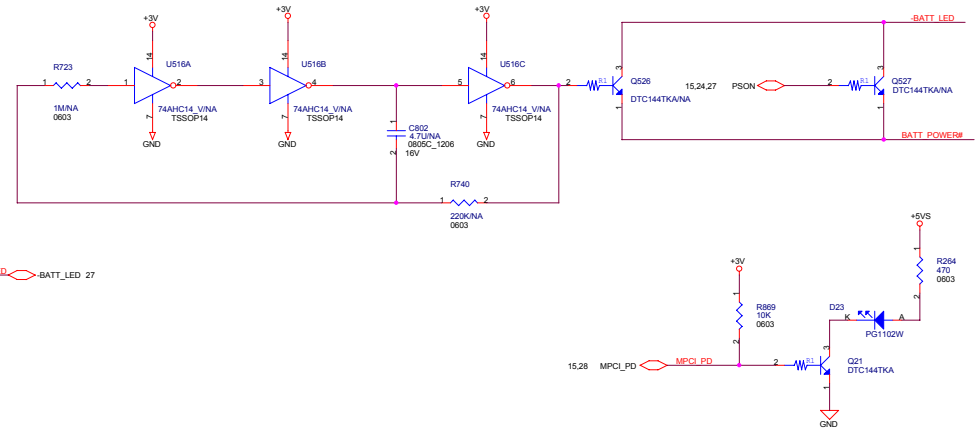

LCD CONNECTOR

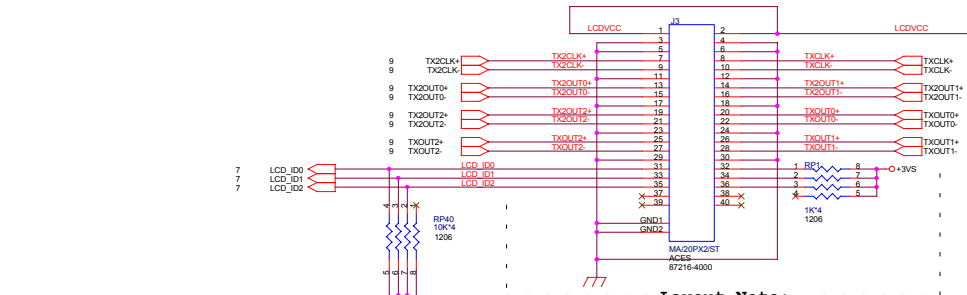

LCD 14" 330mA, 15" 800mA

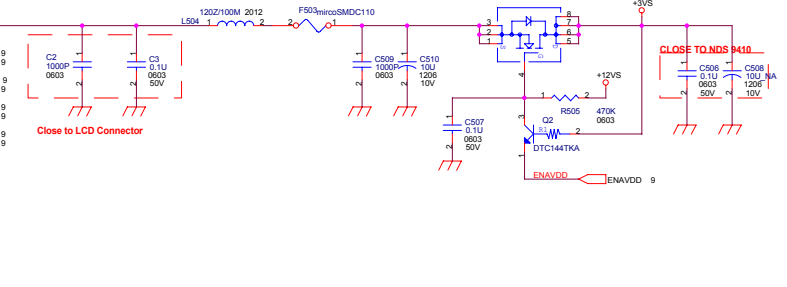

Layout Note:

S/W/S=12/6/6/12 mils as short as possible
四組各自平行走線等長

DISPLAY	LCD_ID2	LCD_ID1	LCD_ID0
UNIQAC	0	0	1
HYUNDAI	0	1	0
HANNSTAR	0	1	1
CMO	1	0	0

W/S=16/12/12/12/16 mils

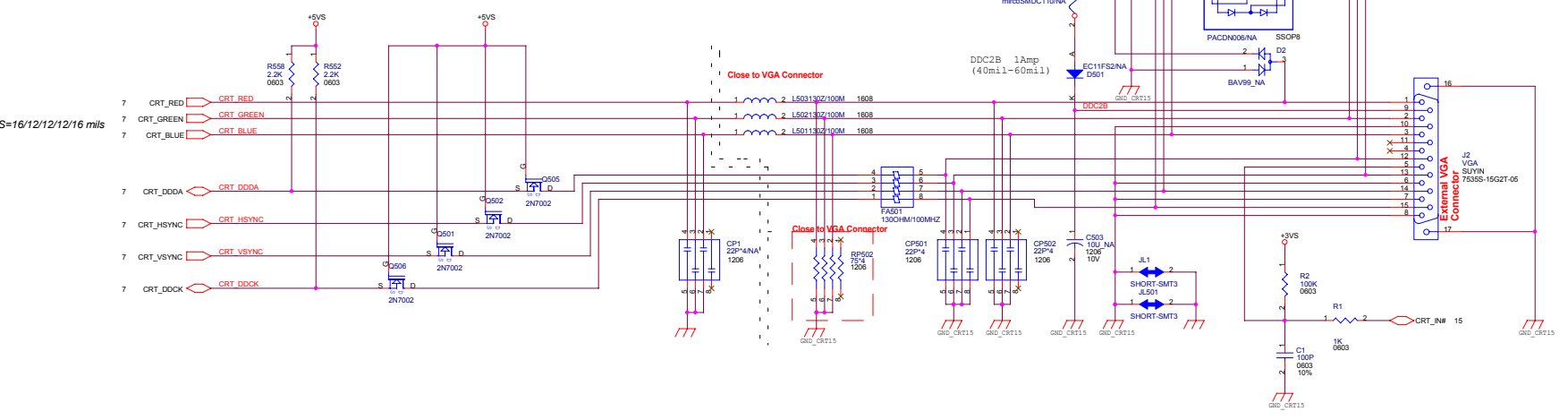

Title: 8575A LCD/VGA INTERFACE
 Size: Document
 Number: BD 31167170001 & TU 411671700011
 Date: Modsys, June 17, 2002
 Sheet: 10 of 30

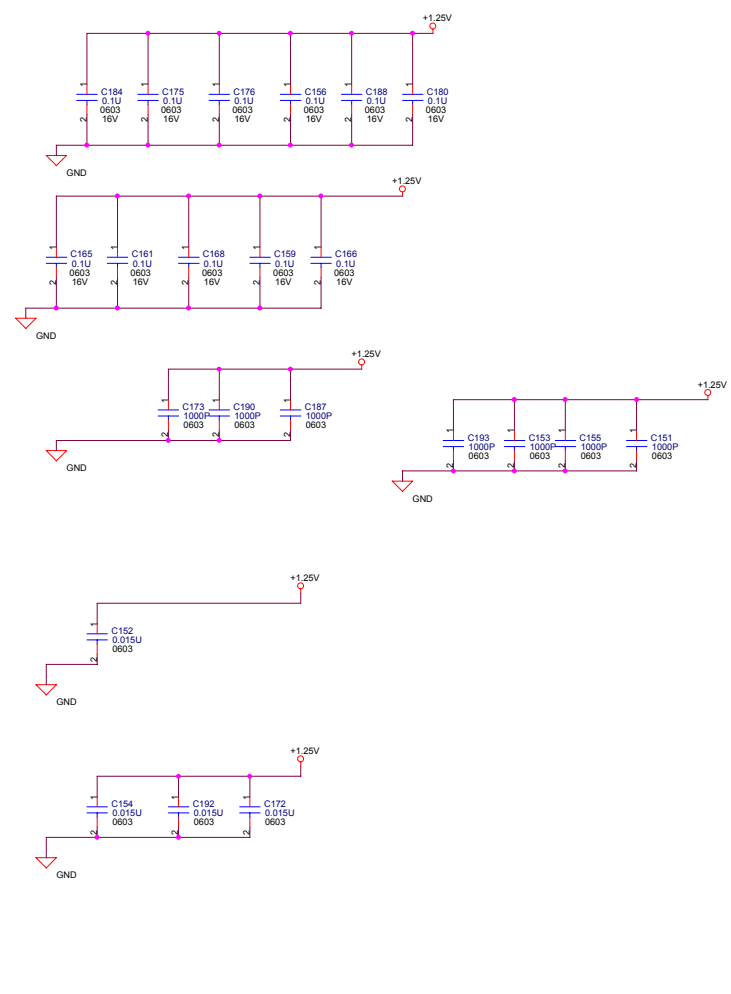
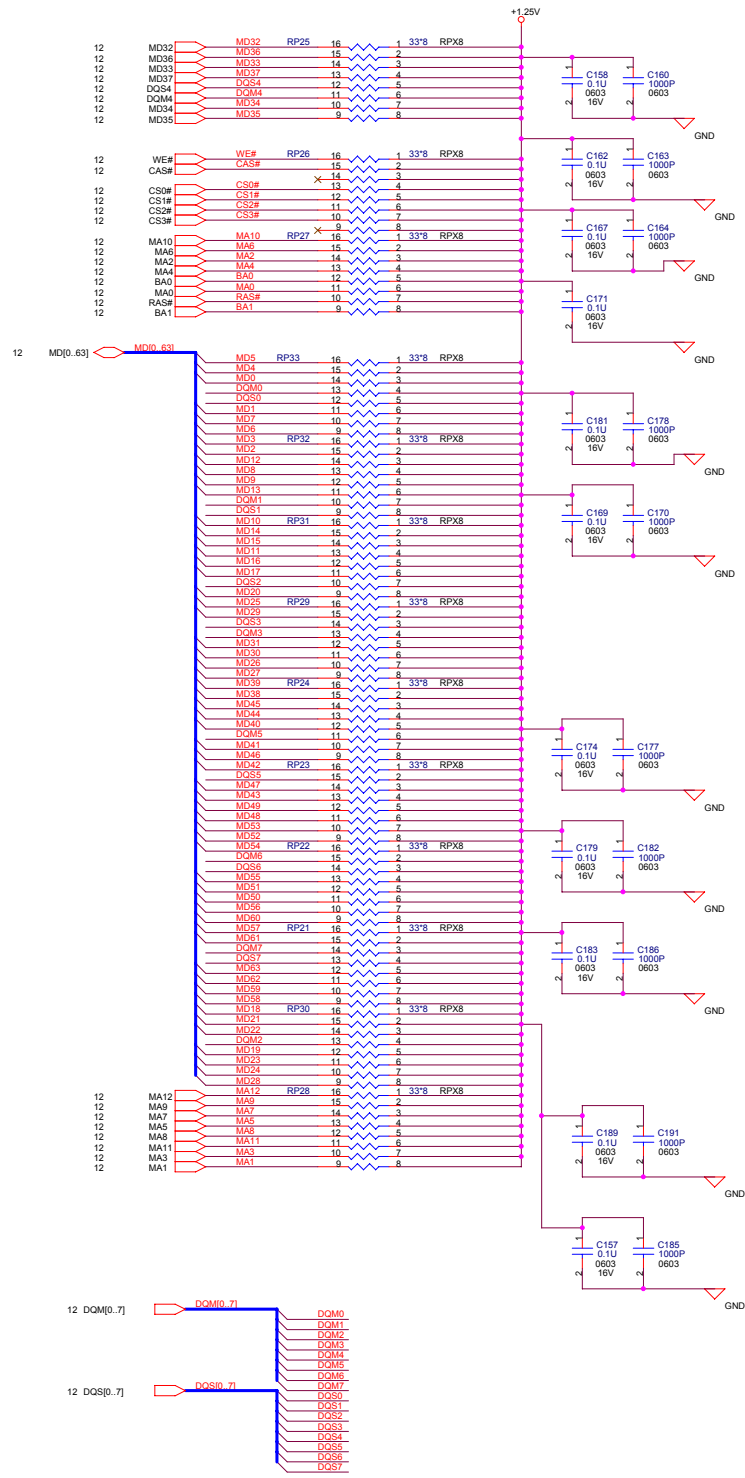

THESE DECOUPLING CAPACITOR SHOULD BE PLACE WITHIN 150 Mils OF +1.25V THERMINATION R-PACKS

SIS961(1/3)

18,28,29 PCI_AD[0..31] PCI_AD0_31

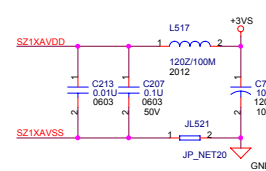
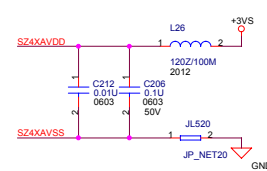
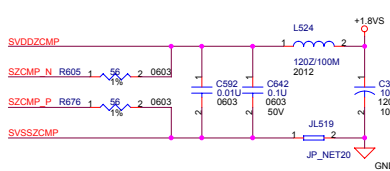
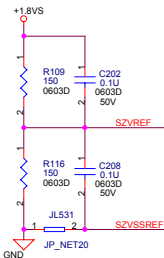
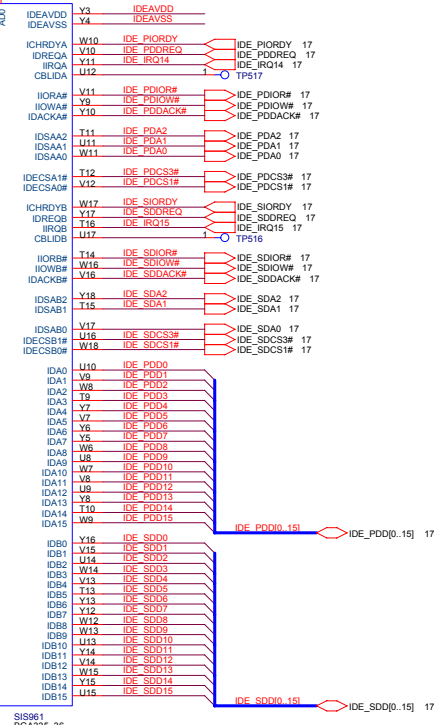
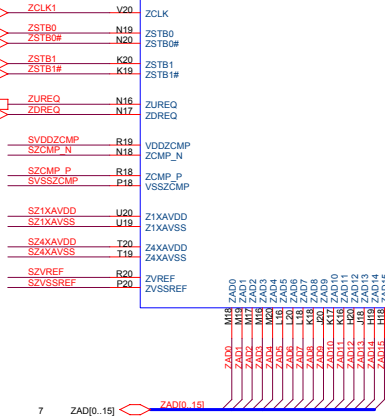
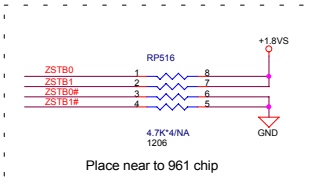
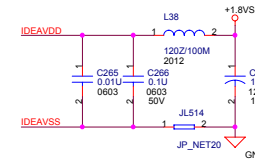
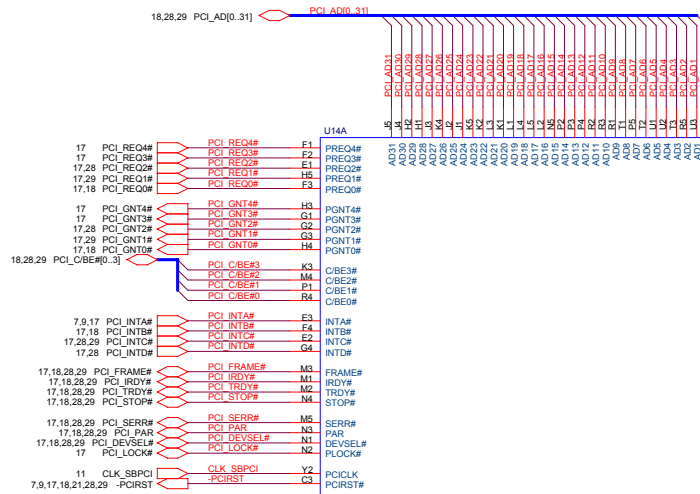

MITAC		
Title 8575A SIS961 (1/3)		
Size C	Document Number BD 31167170001 & TU 41167170011	Rev 01
Date: Monday, June 17, 2002	Sheet 14	of 30

SIS961(3/3)

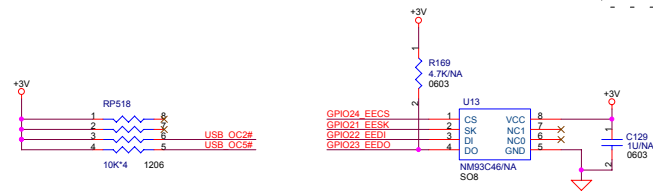
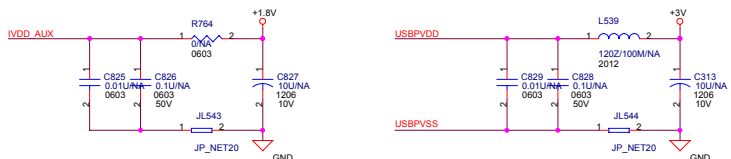
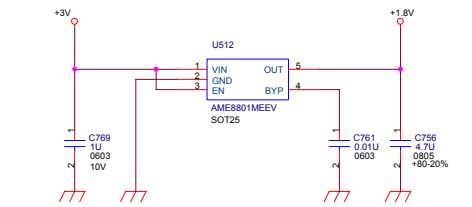
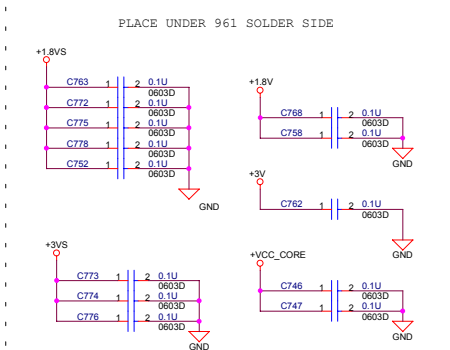
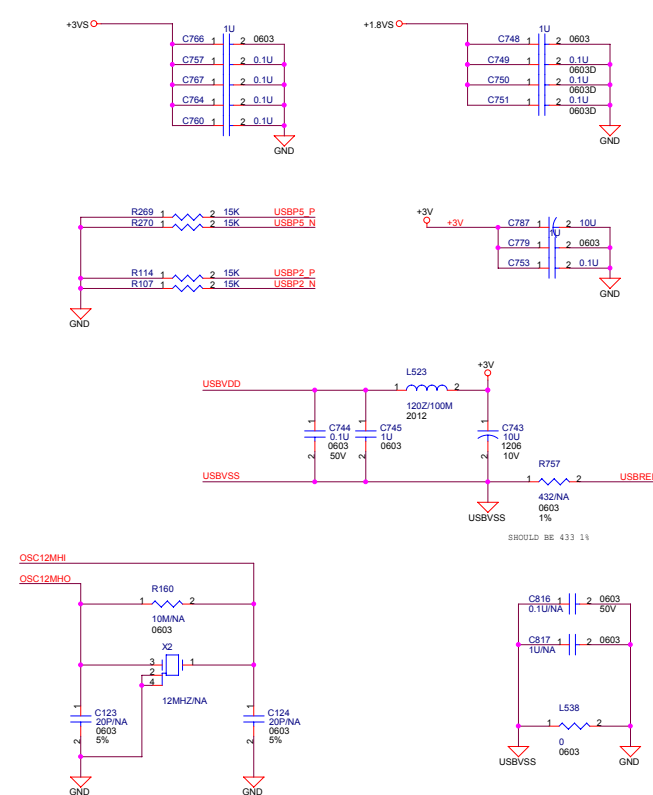
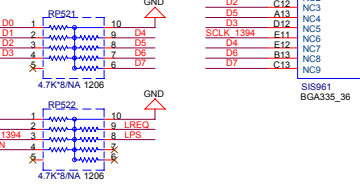
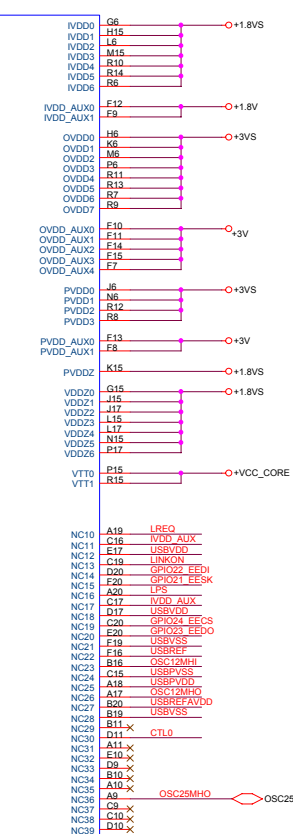
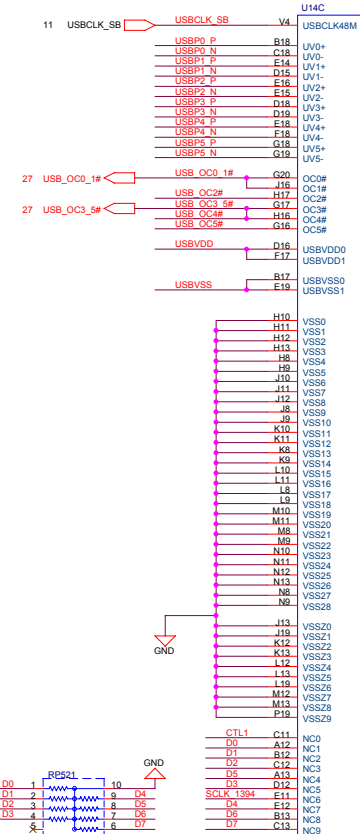
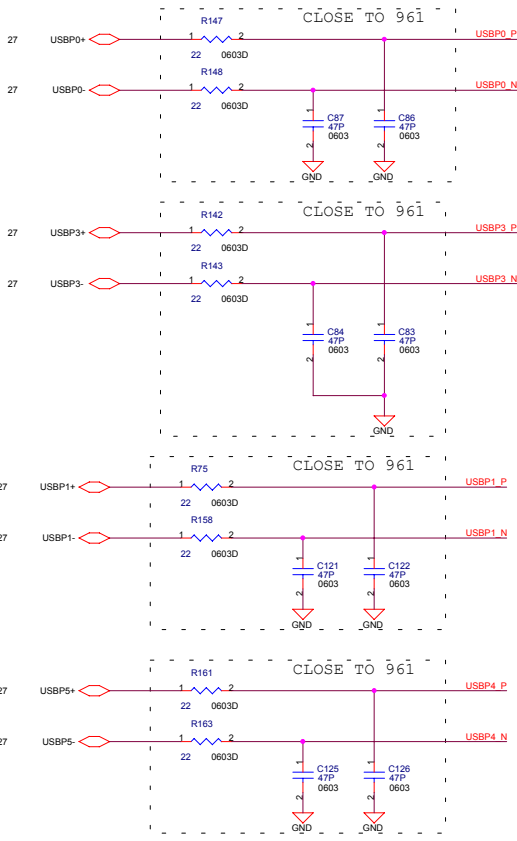

	0	1	Default
SB_SPKR (LPC addr mapping)	disable	enable	0
AC97_SDOUT (PCI CLK PLL)	enable	disable	0
USB_OC2# (SB debug mode)	enable	disable	1
USB_OC5# (Trap mode)	FCI AD	ROM	1

MITAC

Title: 8575A SIS961 (3/3)

Size: C

Document Number: BD 311671700001 & TU 411671700011

Date: Monday, June 17, 2002

Sheet: 16 of 30

Rev: 01

PCI1410

AD20
PCI_INTB#
REQ0#/GNT0#

PCMCIA CONTROLLER & CARDBUS SOCKET

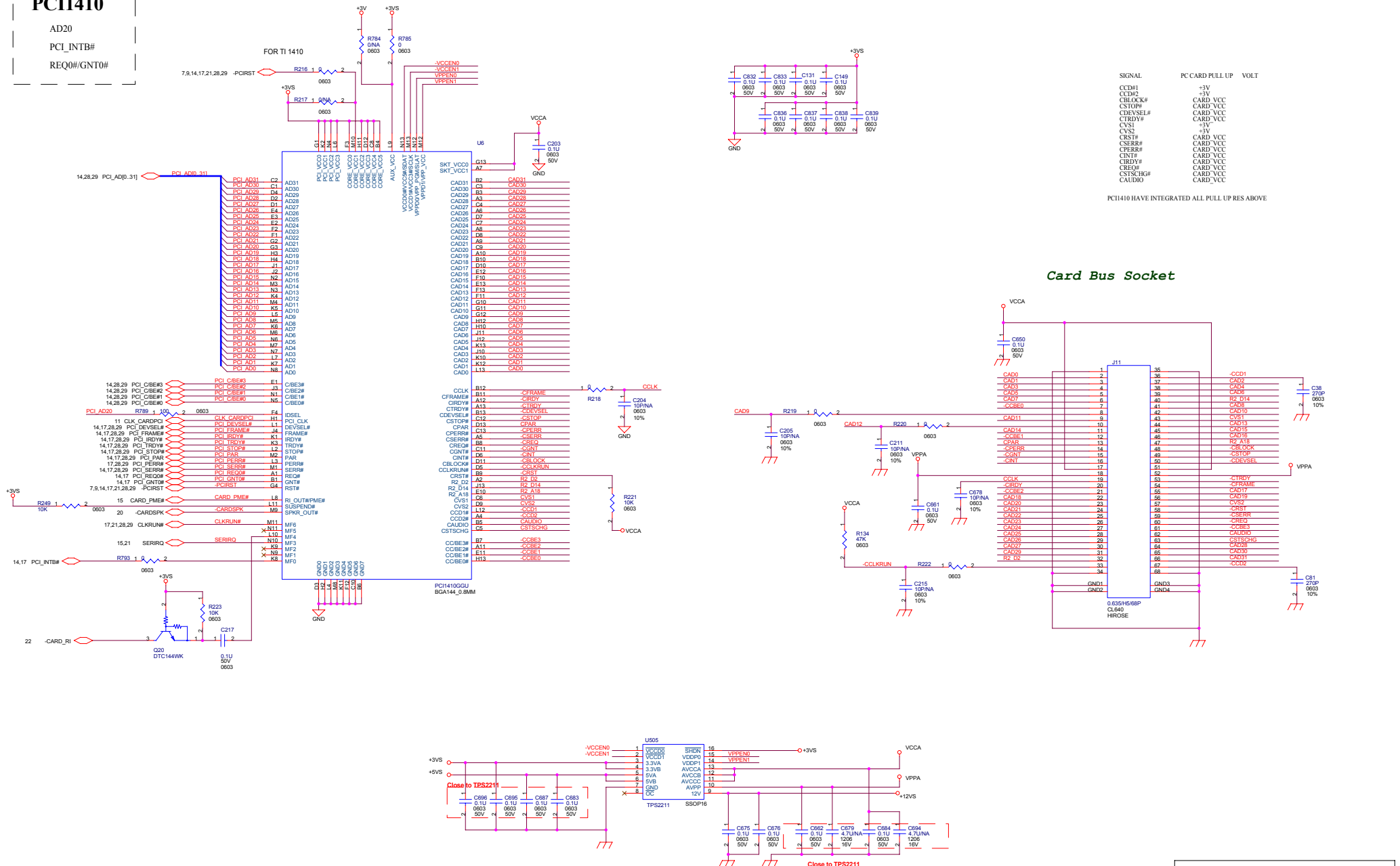

AUDIO CODE & AMPLIFIER

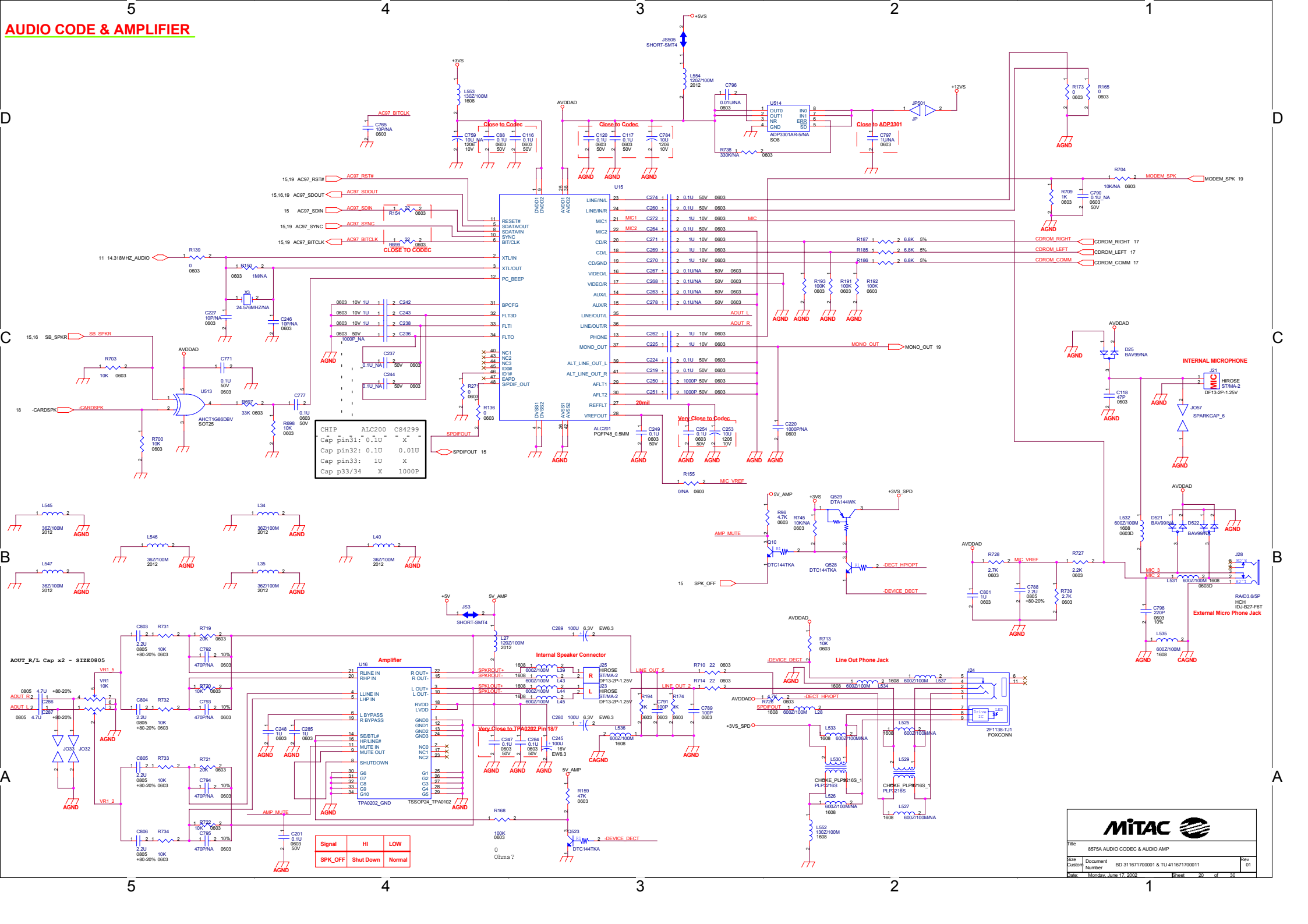

CHIP ALC200 CS4299
 Cap pin31: 0.1u X
 Cap pin32: 0.1u 0.01u
 Cap pin33: 1u X
 Cap p33/34 X 1000P

Signal	HI	LOW
SPK_OFF	Shut Down	Normal

MITAC

Title: 8575A AUDIO CODEC & AUDIO AMP
 Size: Document
 Customer: Number: BD 31167170001 & TU 411671700011 Rev: 01
 Date: Monday, June 17, 2002 Sheet: 20 of 30

1.25V CM8500 & BATTERY CONNECTOR

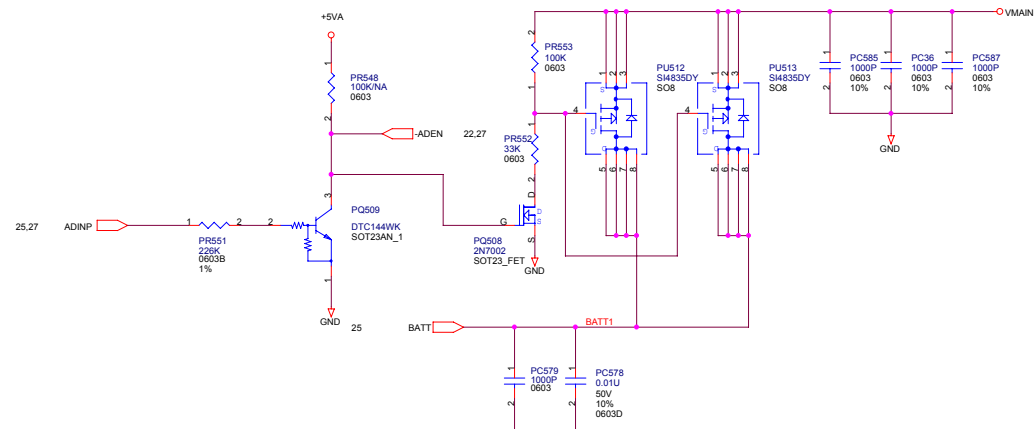
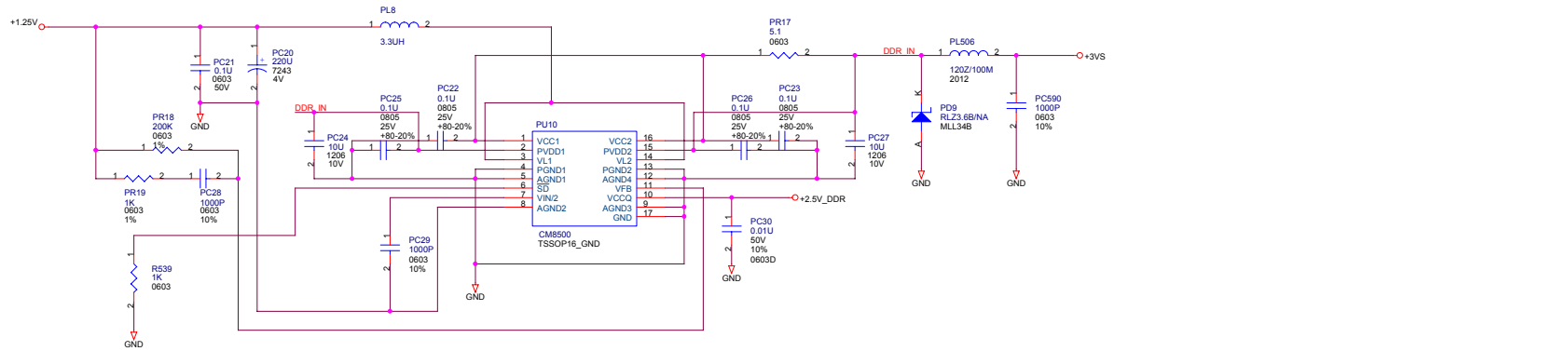

Battery connector

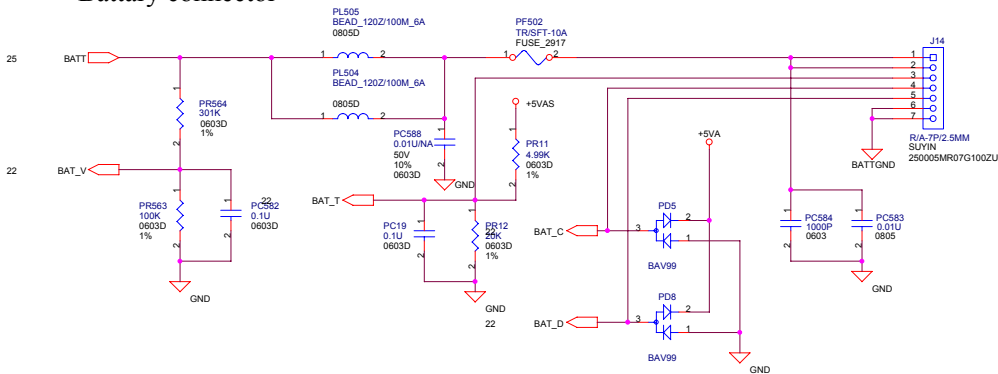

File		
8575A Bat con, DDR 1.25V		
Size	Document	Rev
C	BD 311671700001 & TU 411671700011	01
Date	Monday, June 17, 2002	Sheet 23 of 30

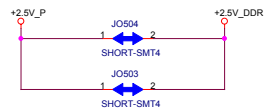
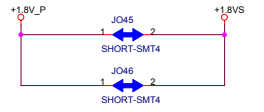
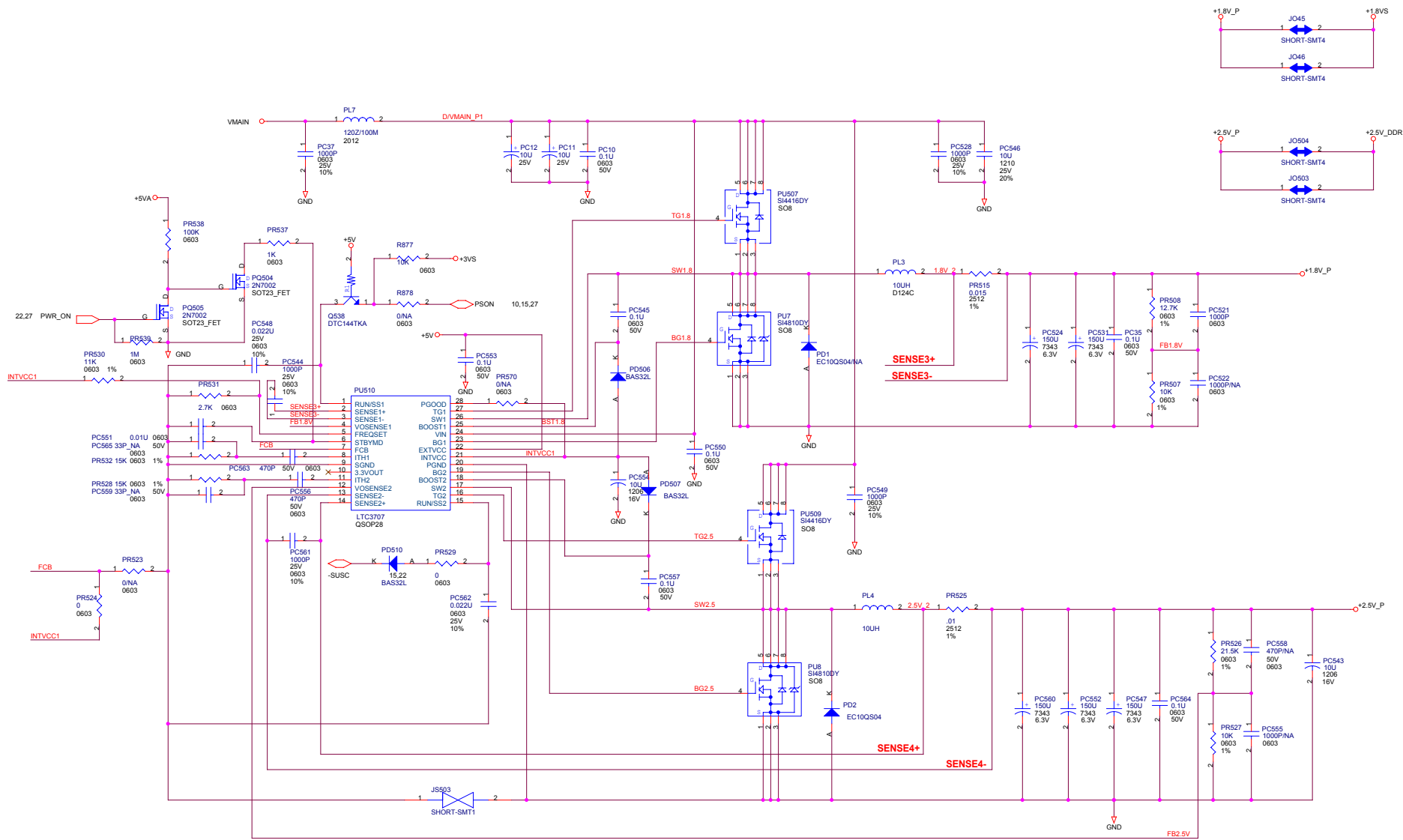

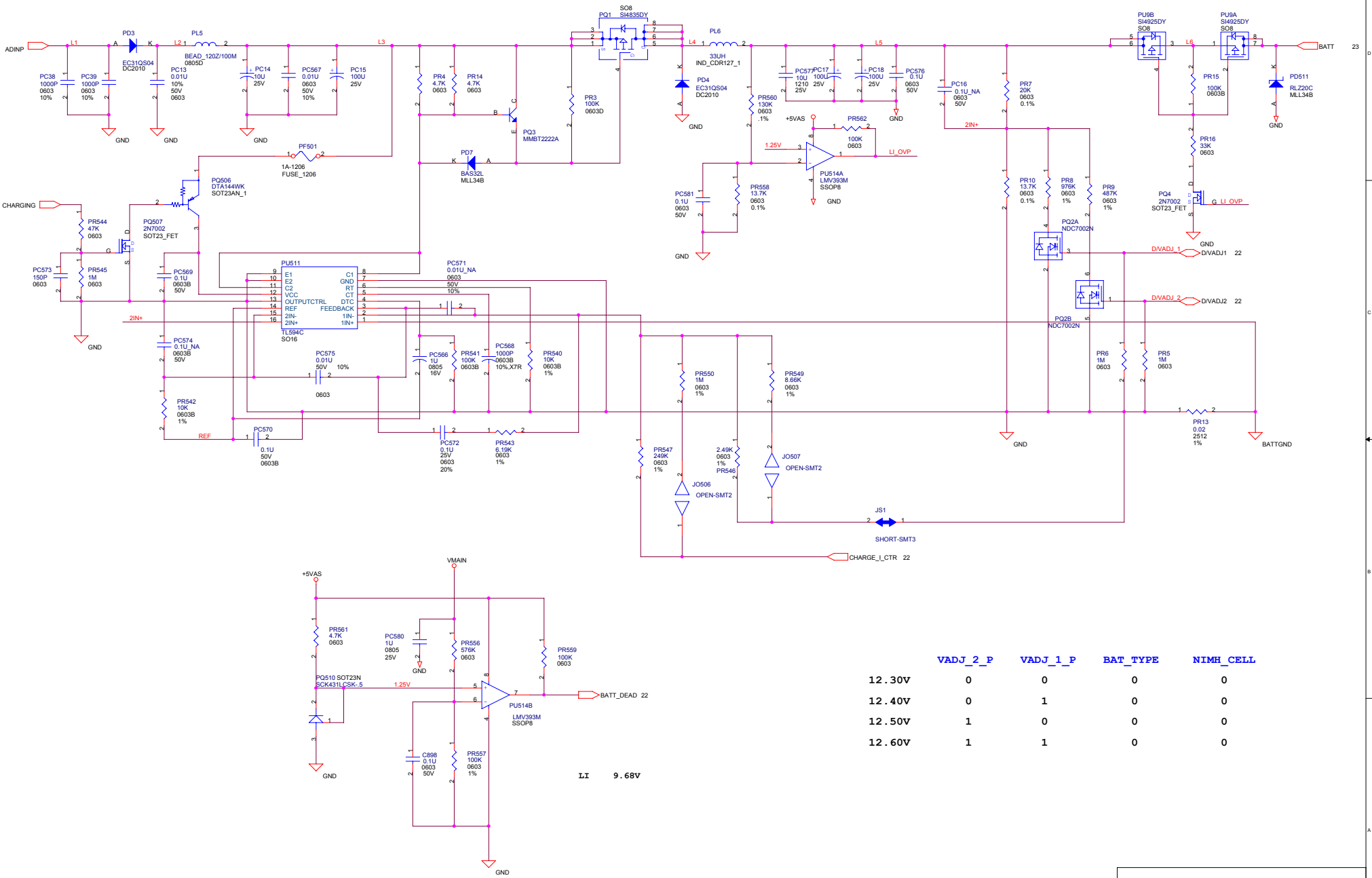

	VADJ_2_P	VADJ_1_P	BAT_TYPE	NIMH_CELL
12.30V	0	0	0	0
12.40V	0	1	0	0
12.50V	1	0	0	0
12.60V	1	1	0	0

LI 9.68V

MITAC

File 8575A Charger		
Size C	Document Number BD 311671700001 & TU 411671700011	Rev 01
Date	Monday, June 17, 2002	Sheet 25 of 30

CPU CORE

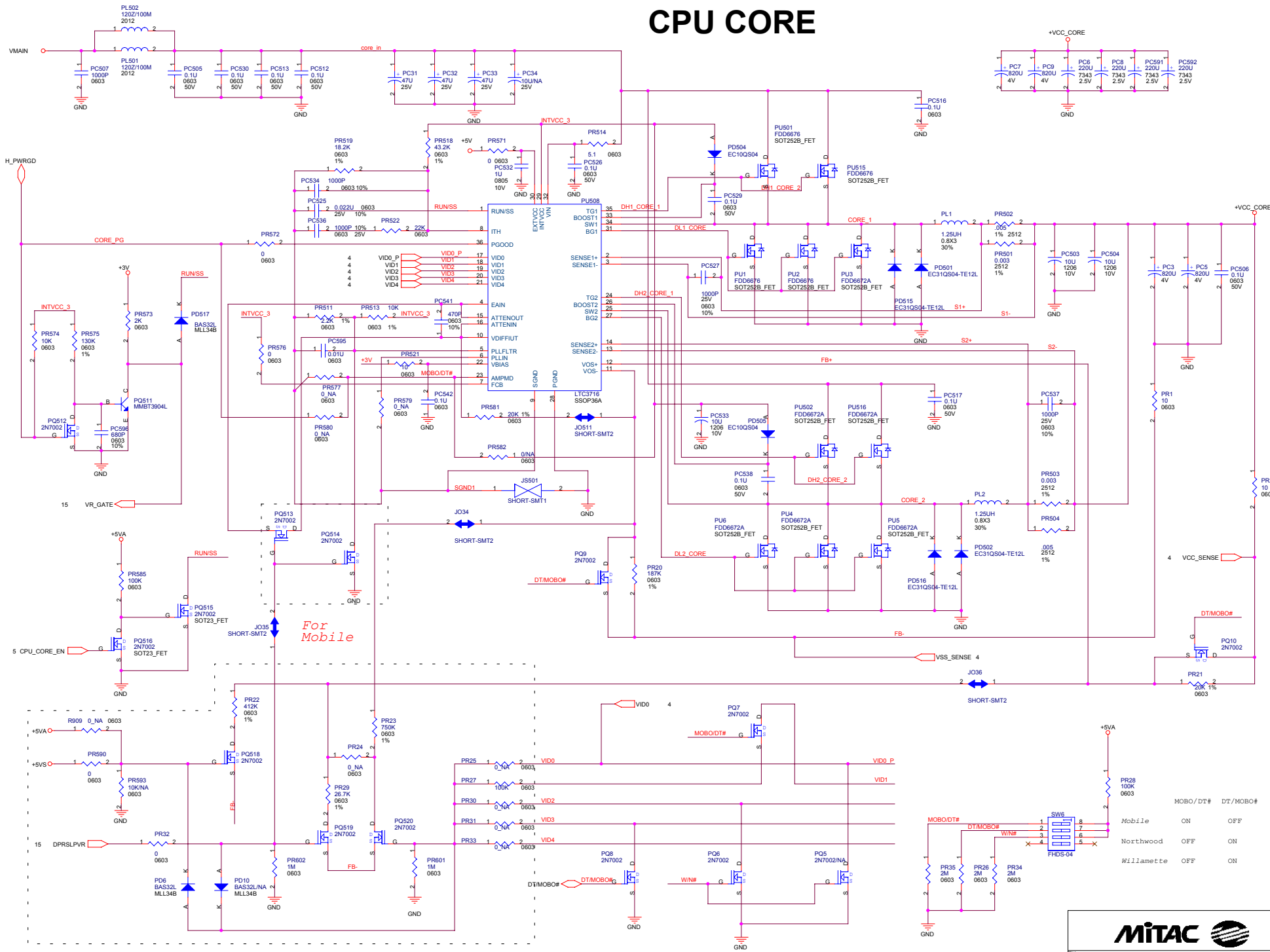

File 8575A CPU CORE		
Size C	Document Number BD 311671700001 & TU 411671700011	Rev 01
Date Monday, June 17, 2002	Sheet 26	of 30

	MOBO/DT#	DT/MOBO#	W/#
Mobile	ON	OFF	OFF
Northwood	OFF	ON	OFF
Willamette	OFF	ON	ON

+5VA

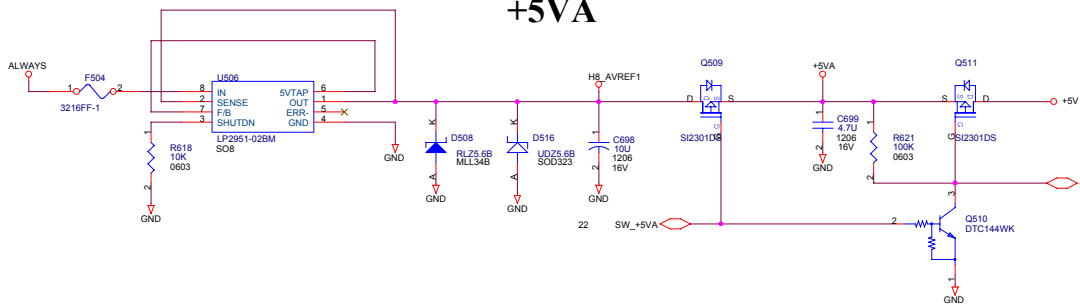

+5VAS

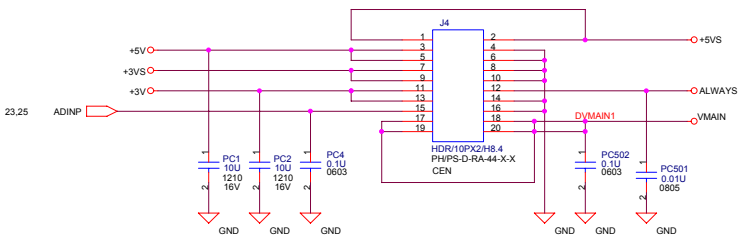
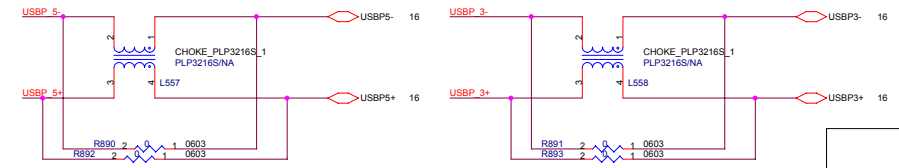
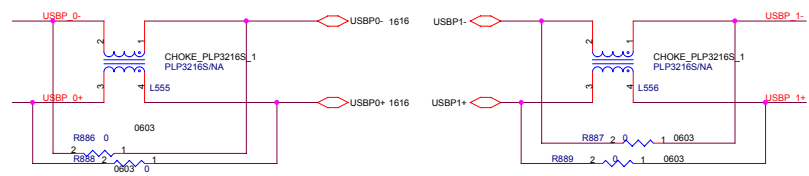
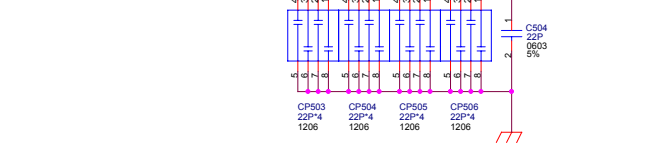
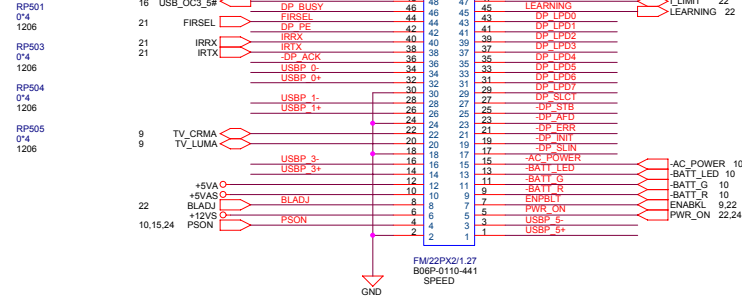
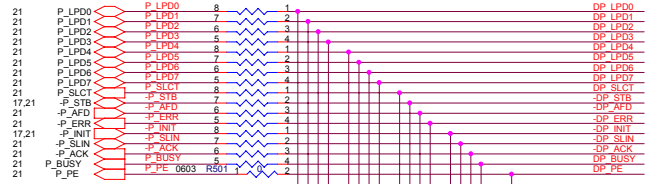
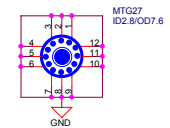
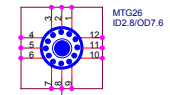
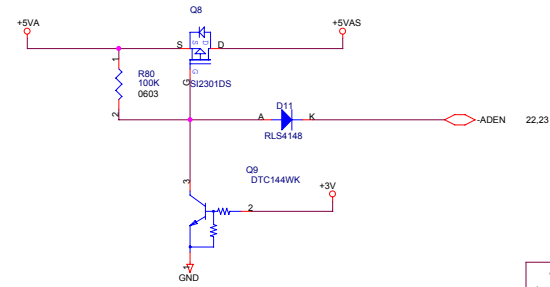

MINI-PCI

AD21
PCI_INTD#
REQ2#/GNT2#

MINI-PCI

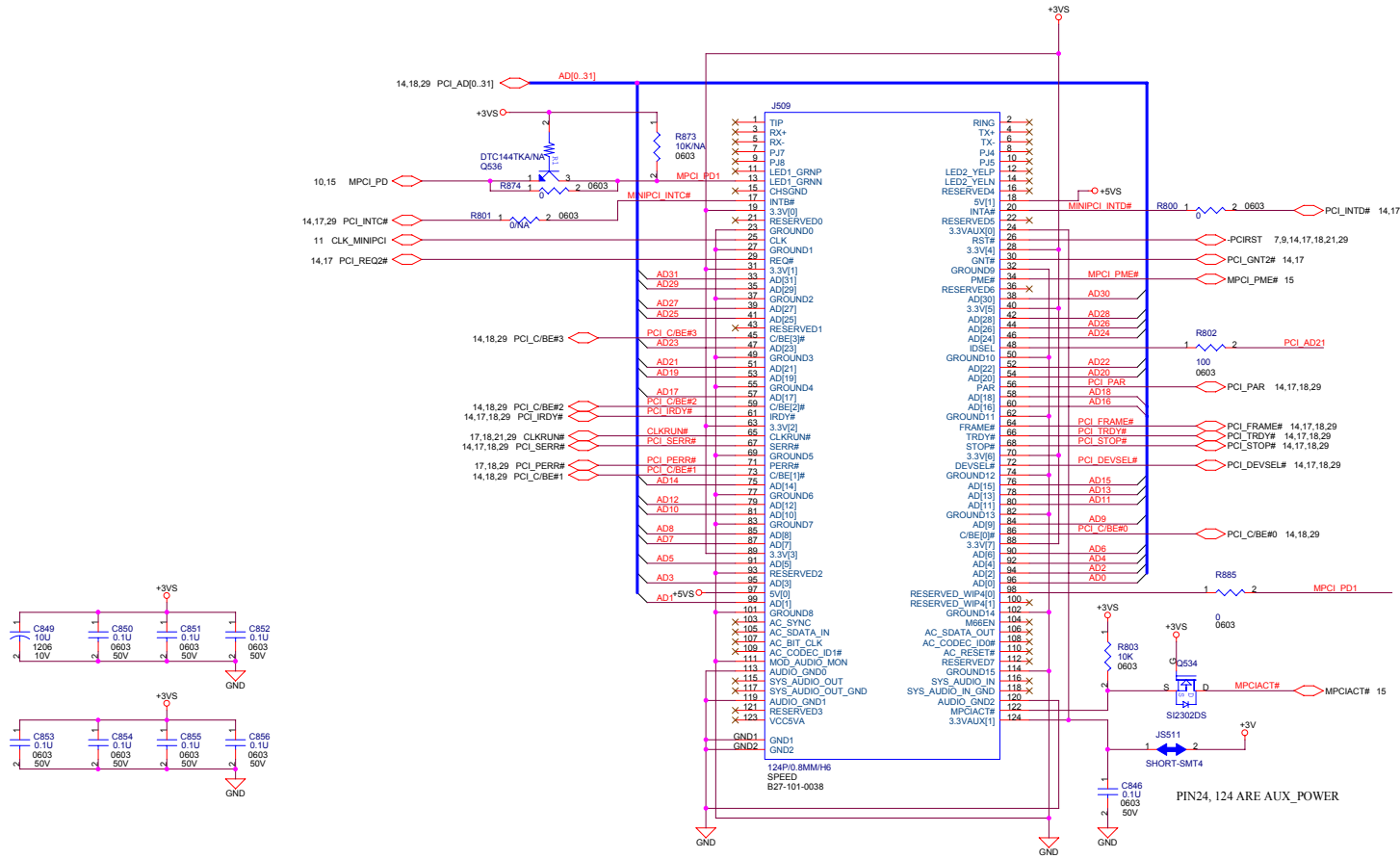

Title 8575A Mini PCI		
Size C	Document Number	Rev 01
BD 311671700001 & TU 411671700011		
Date: Monday, June 17, 2002	Sheet 28	of 30

NEC UPD72872

AD22
INTC#
REQ1#/GNT1#

IEEE1394-uPD72872

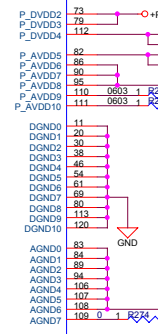
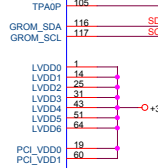
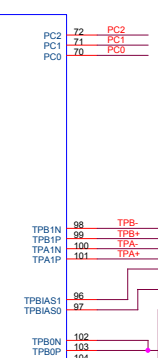
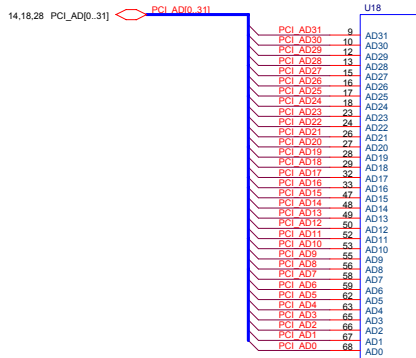
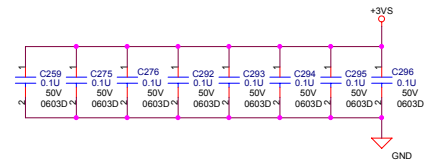

R10 & R11 connect an external resistor of 9.1K 0.5% to limit the LSI's current.

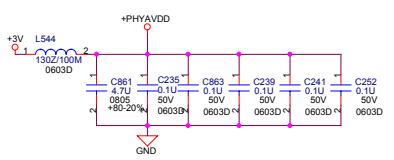
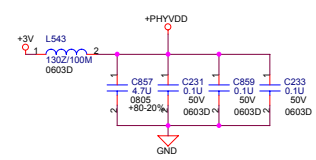
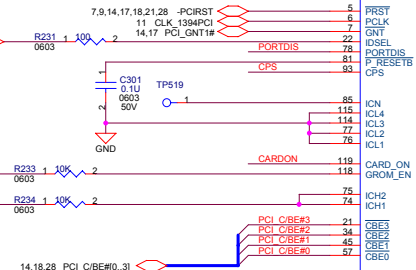

	uPD72872	uPD72873/74
R227	0	NA
R229	NA	0
R811	NA	R811
R813	0	NA
R230	NA	0
R882	0	NA
R883	0	NA
R884	0	NA

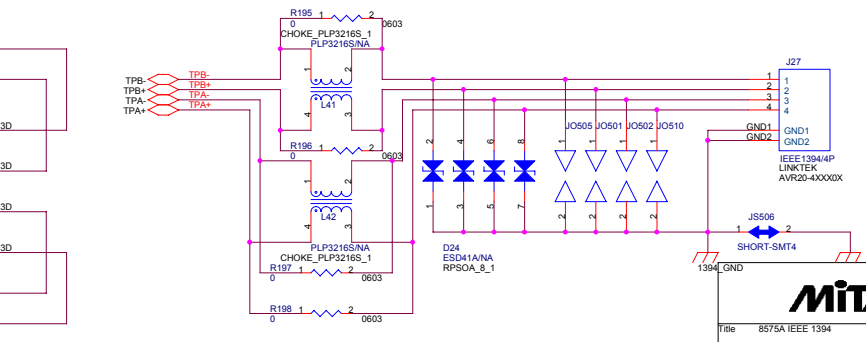
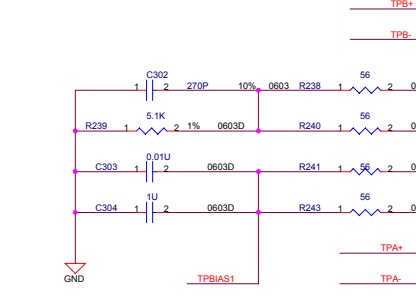
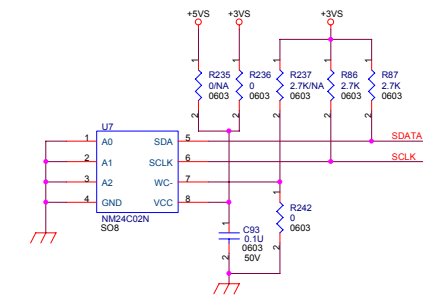
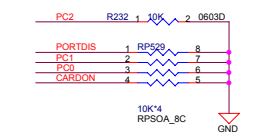
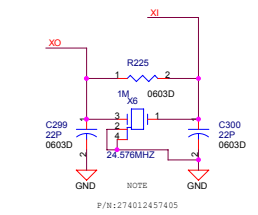
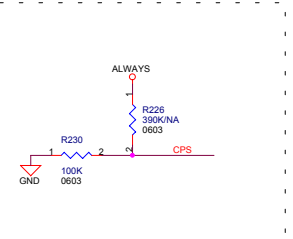

MITAC

Title: 8575A IEEE 1394
 Size: C
 Document Number: BD 311671700001 & TU 411671700011
 Date: Monday, June 17, 2002
 Sheet: 29 of 30
 Rev: 01

8575 A MB R01

R00	First Generation
R0A PVT	Page-15 R280,R281.D26 -->DEL Page-15 R257 (VR HI/LO#/100K-->Pull-down Page-22 R909 to +5V/A/NA Reserve for Pull-up
R01 MP	

		
Title 8575A M/B Revision		
Size C	Document Number BD 311671700001 & TU 411671700011	Rev 01
Date: Monday, June 17, 2002	Sheet 30	of 30

8575/8575N DD BOARD R0A

SYSTEM POWER (+3V +5V +12V)

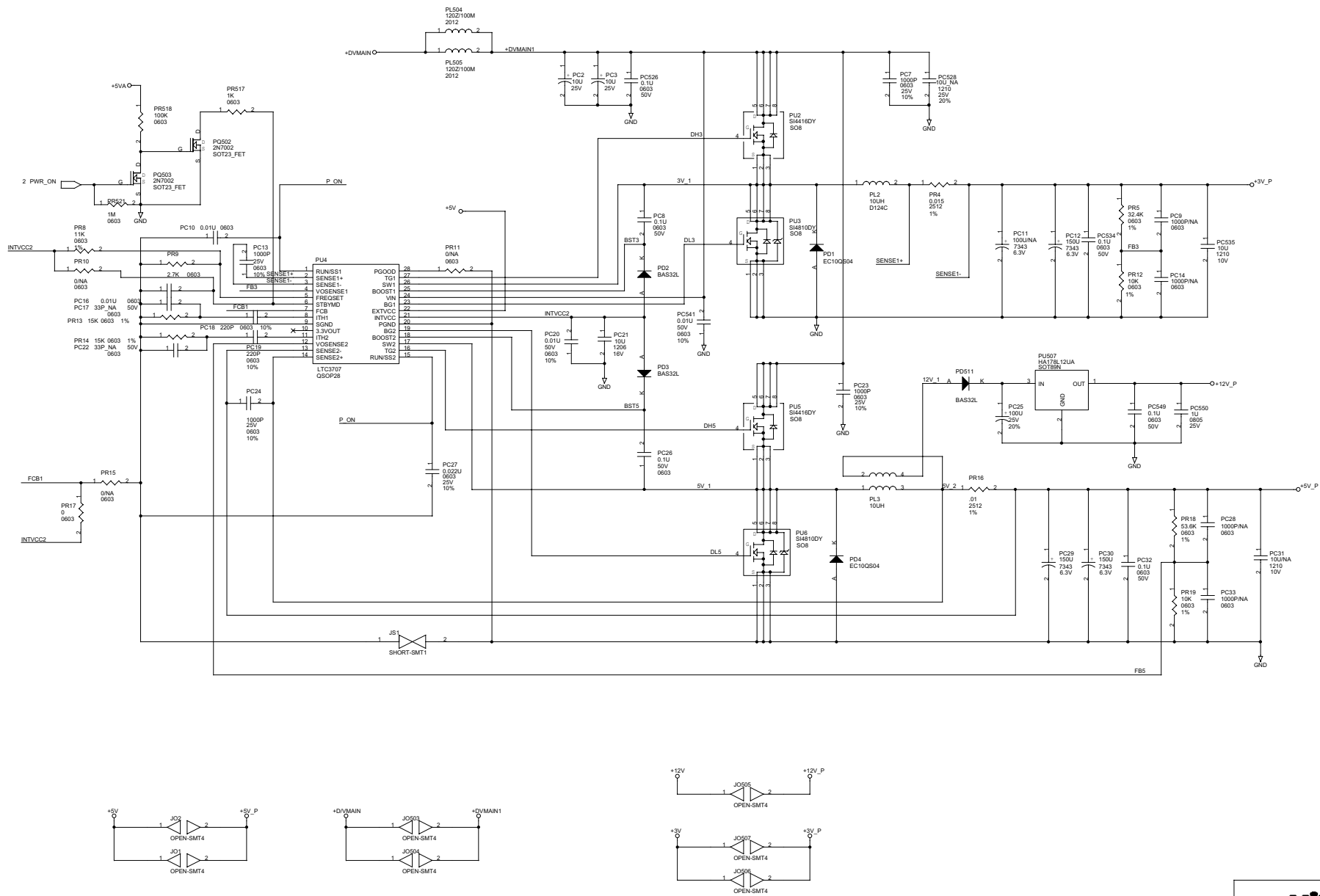

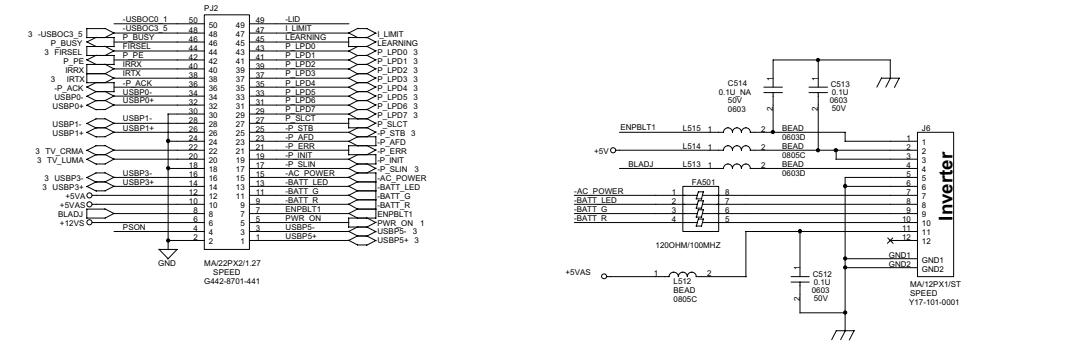
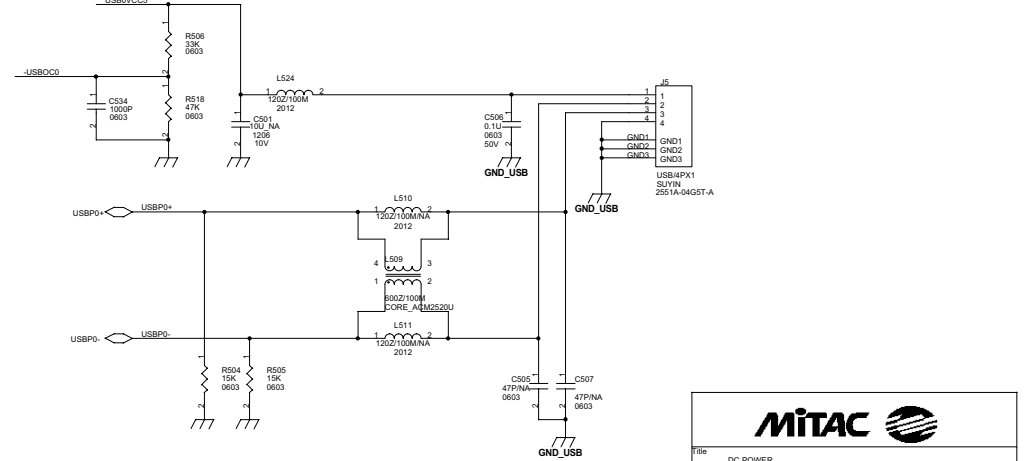
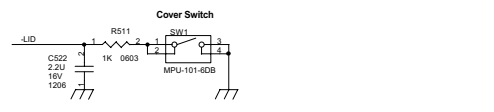
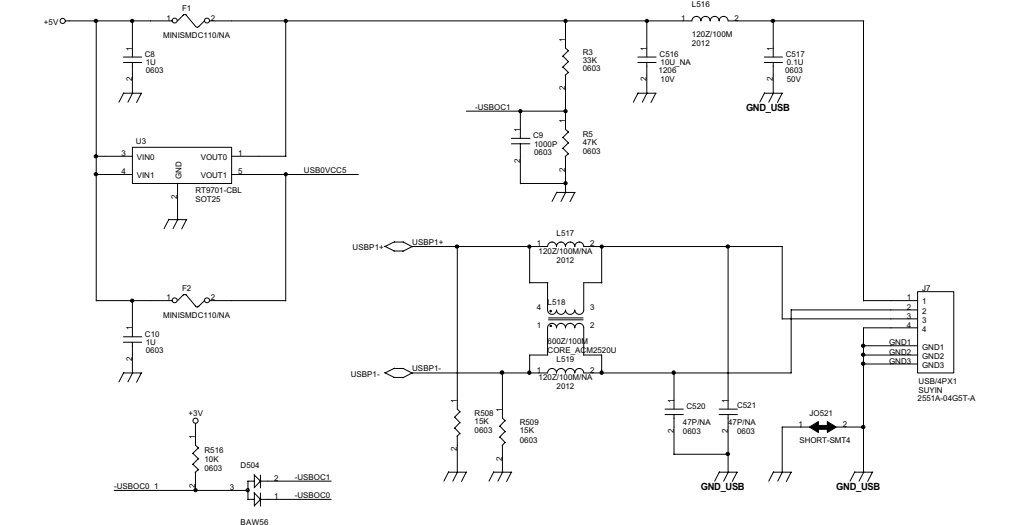
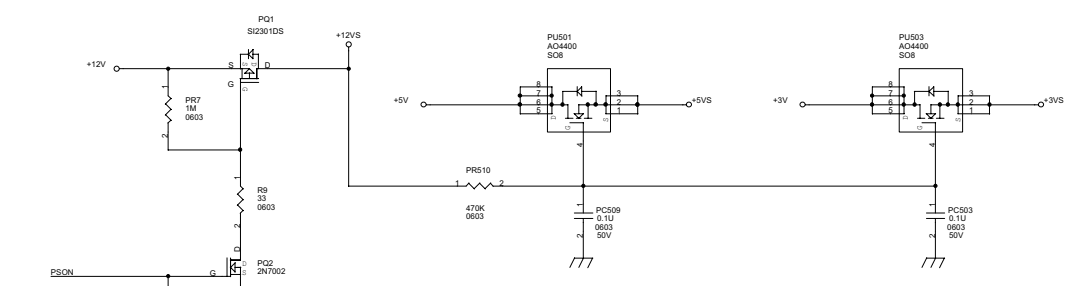
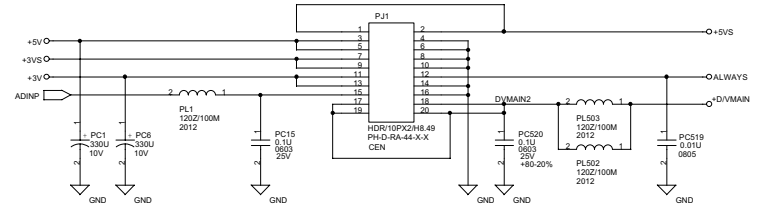
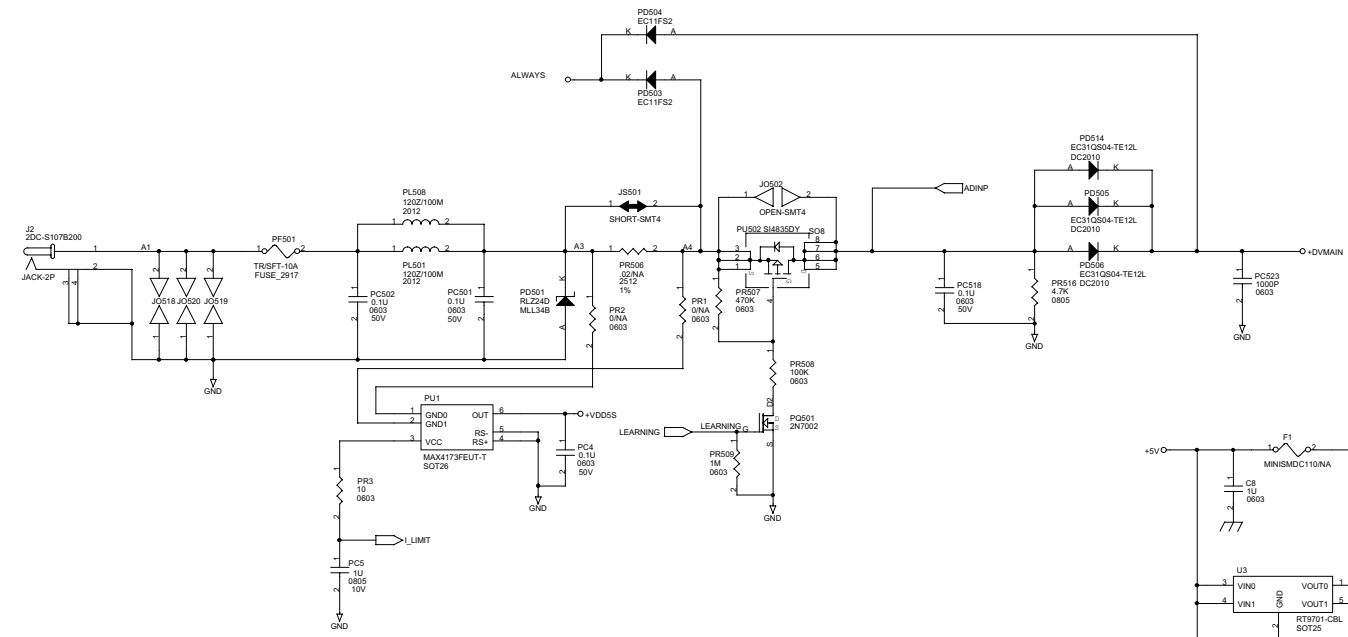

Symbol	Value	Footprint	Reference
3	-.USB0C3_5	50	49
3	P_BUSV	46	48
3	FIRSEL	44	44
3	IRRX	42	41
3	IRTX	38	37
3	P_AOK	36	36
3	USBP0_	34	33
3	USBP0+	32	31
3	USBP0-	30	29
3	USBP1_	28	27
3	USBP1+	26	25
3	USBP1-	24	23
3	TV_LUMA	20	19
3	USBP3_	18	18
3	USBP3+	16	14
3	USBP3-	14	13
3	+5V_A0	10	9
3	+5V_A0C	8	8
3	BLAD	6	5
3	+12V_S	2	1

MITAC

File: DC POWER

Size: Document 41167170004 Rev: 0A

Date: Monday, January 14, 2002 Sheet: 2 of 3

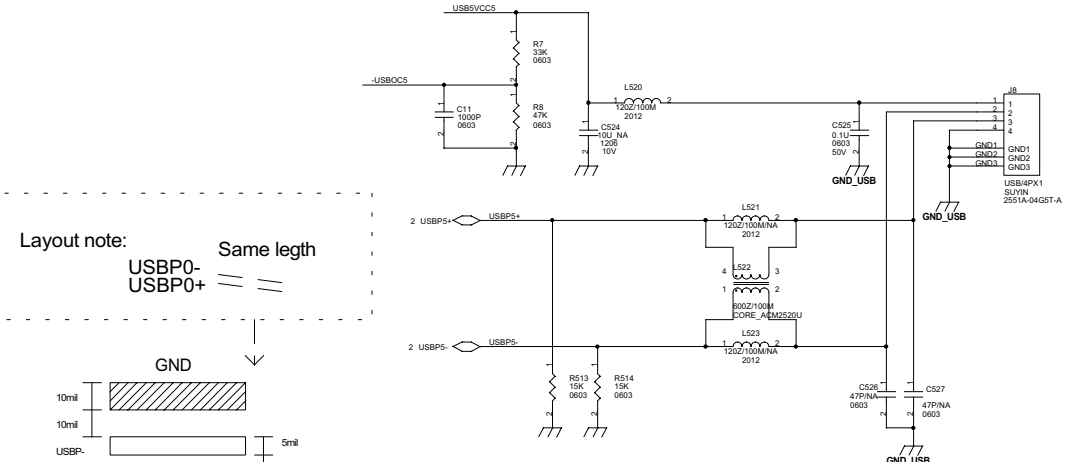
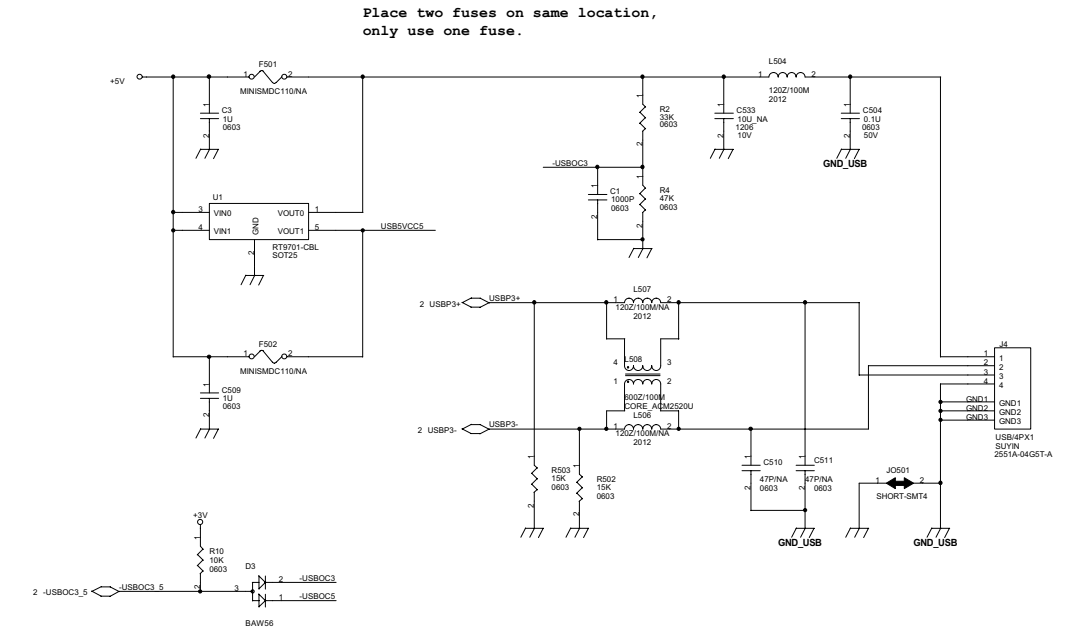
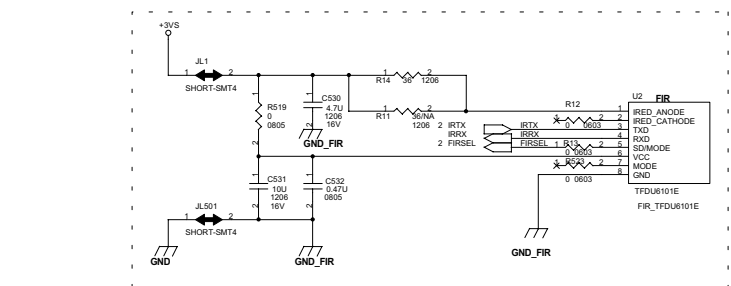
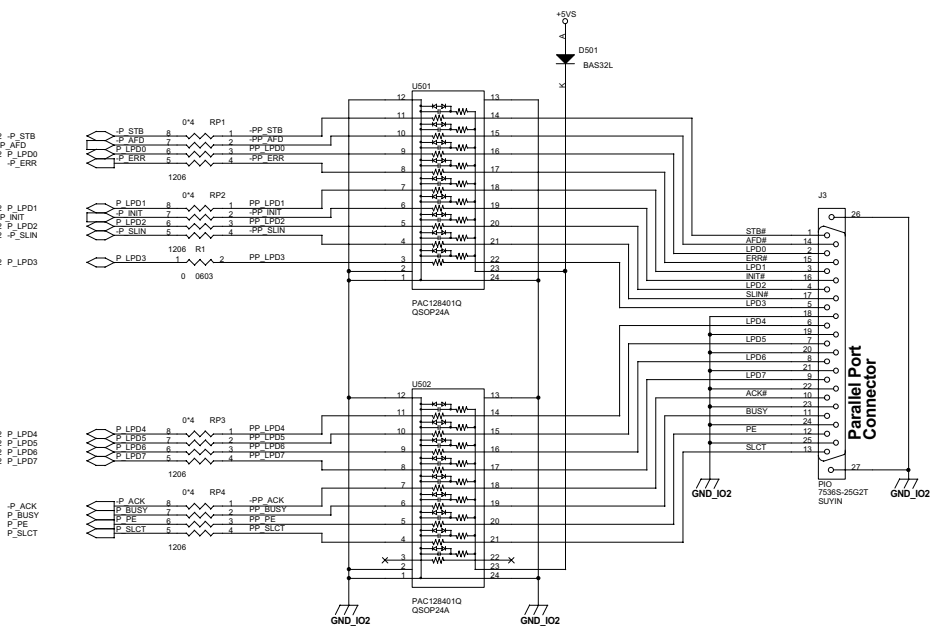
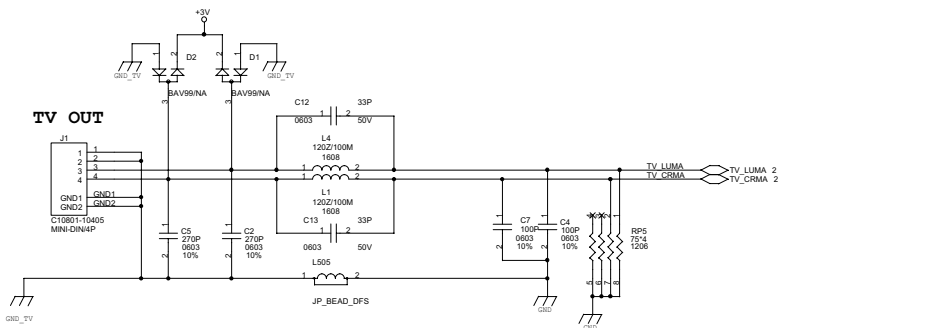

Layout note:
USBP0-
USBP0+
= =

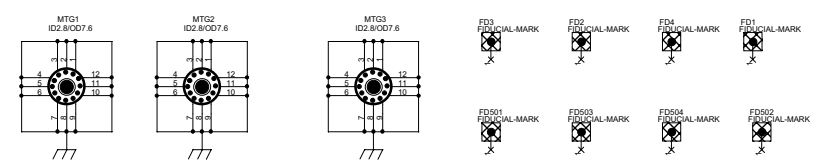
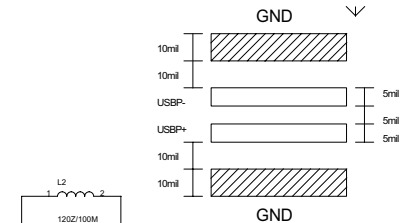

Place two fuses on same location,
only use one fuse.

Reference Material

- ❖ Intel Pentium 4 Processor mPGA478 Socket Intel, INC
- ❖ SiS650 IGUI Host / Memory Controller SiS, INC
- ❖ SiS691 MuTIOL Media I/O Controller SiS, INC
- ❖ SiS301LV / Chrontel CH7019 TV/LVDS Encoder SiS, INC
- ❖ PCI1410GGU PCMCIA Controller TI, INC
- ❖ uPD72872 IEEE1394 Controller NEC, INC
- ❖ 8575A Hardware Engineering Specification *Technology Corp./MiTAC*

SERVICE MANUAL FOR 8575A

Sponsoring Editor : Jesse Jan

Author : Sissel Diao

Assistant Editor : Janne Liu

Publisher : MiTAC International Corp.

Address : 1, R&D Road 2, Hsinchu Science-Based Industrial, Hsinchu, Taiwan, R.O.C.

Tel : 886-3-5779250

Fax : 886-3-5781245

First Edition : Aug. 2002

E-mail : Willy.Chen @ mic.com.tw

Web : <http://www.mitac.com>

<http://www.mitacservice.com>
