



Color OneScanner 600/27





Basics

Apple Color OneScanner 600/27





Overview

The Color OneScanner 600/27 is a compact, digital-image color scanner with a maximum mechanical resolution of 300 x 600 dpi.

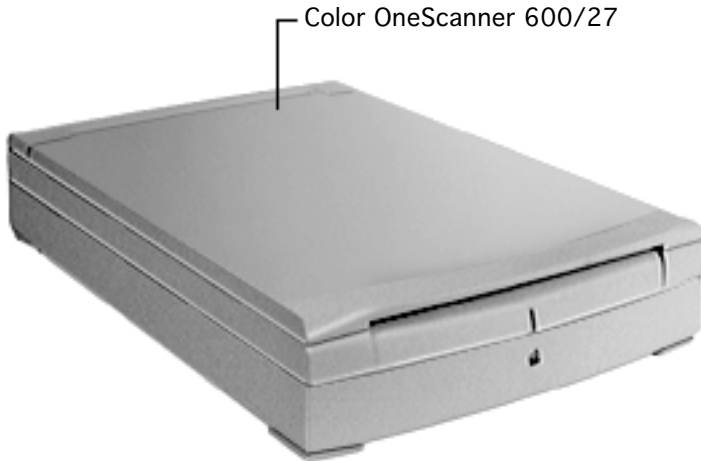



An optional accessory for the Color OneScanner 600/27 is an Automatic Document Feeder (ADF) with a 20-sheet capacity paper tray.

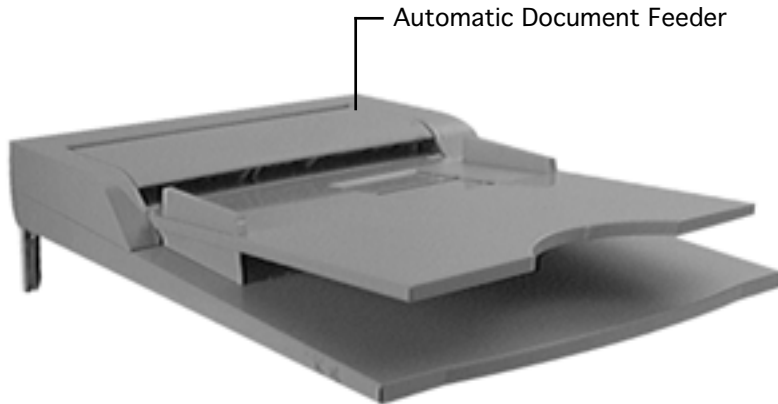



Scanner Features

Features of the Color OneScanner 600/27 include the following:

- 300 x 600 dpi optical, 2400 x 2400 dpi interpolated, resolution for improved Optical Character Recognition (OCR) accuracy
- 27-bit scanning depth color that recognizes up to 134-million colors
- Support for PICT, TIFF, JPEG, EPS, BMP, and Photoshop; compatible with most popular word processing, presentation, image-editing, page layout, and web-authoring software for the Macintosh
- OneScanner Dispatcher software that integrates with popular applications and provides the tools to scan, edit, and archive images or documents; supports Drag and Drop
- Small desktop footprint of 16.3 in by 11.3 in





- ColorSync for the closest possible color match between what is scanned, seen on the monitor, or printed
- Xerox TextBridge for converting scanned documents into editable text or HTML format for a Web page
- Optional 20-sheet capacity Automatic Document Feeder





Scanner Operation

Clicking the icon at left launches a MoviePlayer animation sequence that shows the following scanning cycles:

- Flatbed scanning where the document remains stationary and the scanner lamp moves to scan from the front
- Automatic Document Feeder (ADF) scanning where the document moves and the scanner lamp remains in one position to scan from the front



Color OneScanner.moov

Note: Also shown in the animation sequence is Transparent Media Adapter (TMA) scanning where the document remains stationary and the TMA lamp moves to scan from the back. This type of scanning is available with the TMA option for the Apple Color OneScanner 1200/30. A TMA option is not available for the Apple Color OneScanner 600/27.





Optical Assembly Handling Precautions

Issue: The Color One Scanner 600/27 optical assembly is being damaged during removal.

Solution: Apple recommends handling the scanner assembly by the longer sides (see illustration on next page) so that the printed circuit board (CCD unit) on the underside will not be damaged. The CCD unit is a delicate part located on the front, or shorter side of the assembly. If a service provider grabs or touches the CCD unit while removing or replacing the scanner, the scanner may not function. In addition, new packing was designed for the scanner unit.

Note: For additional information, refer to the Optical Assembly in Take Apart.



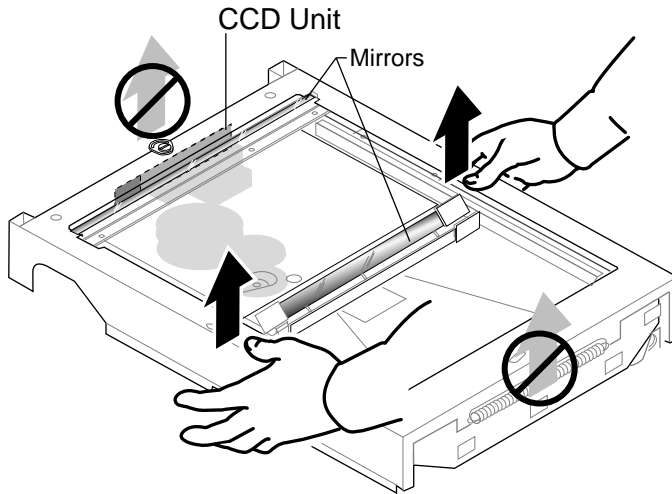

Hold or lift the optical assembly by the long sides, never by the shorter sides.

Caution: Do not touch the printed circuit board (CCD Unit) or the mirrors.





Specifications

Color OneScanner 600/27





Characteristics

Scanner Type	Flatbed, Single pass, 27-bit scanning
Scanner Resolution	300 x 600 dpi 2400 x 2400 dpi interpolated
Maximum Document Size	8.5 by 11.5 in. 8.5 by 14 in. with optional Automatic Document Feeder
Speed	Color: 20 seconds (US letter size) Monochrome: 10 seconds (US letter size)
Interface	SCSI-2





Electrical

Line Voltage	100/120/200/220/240 VAC \pm 10%
Frequency	48-62 Hz \pm 10
Power Consumption	35 W (maximum)





Physical

Size

Height: 3.1 in. (79 mm)

Width: 11.3 in. (287 mm)

Depth: 16.3 in. (414 mm)

Weight

13.2 lb. (6 kg)





Environmental

Temperature 50-90.5°F (10-32.5°C)

Relative Humidity 20-80% noncondensing





Troubleshooting

Color OneScanner 600/27





General

The Symptom Charts included in this chapter will help you diagnose specific symptoms related to your product. Because cures are listed on the charts in the order of most likely solution, try the first cure first. Verify whether or not the product continues to exhibit the symptom. If the symptom persists, try the next cure. (Note: If you have replaced a module, reinstall the original module before you proceed to the next cure.)

For additional assistance, contact Apple Technical Support.





Wiring Diagram

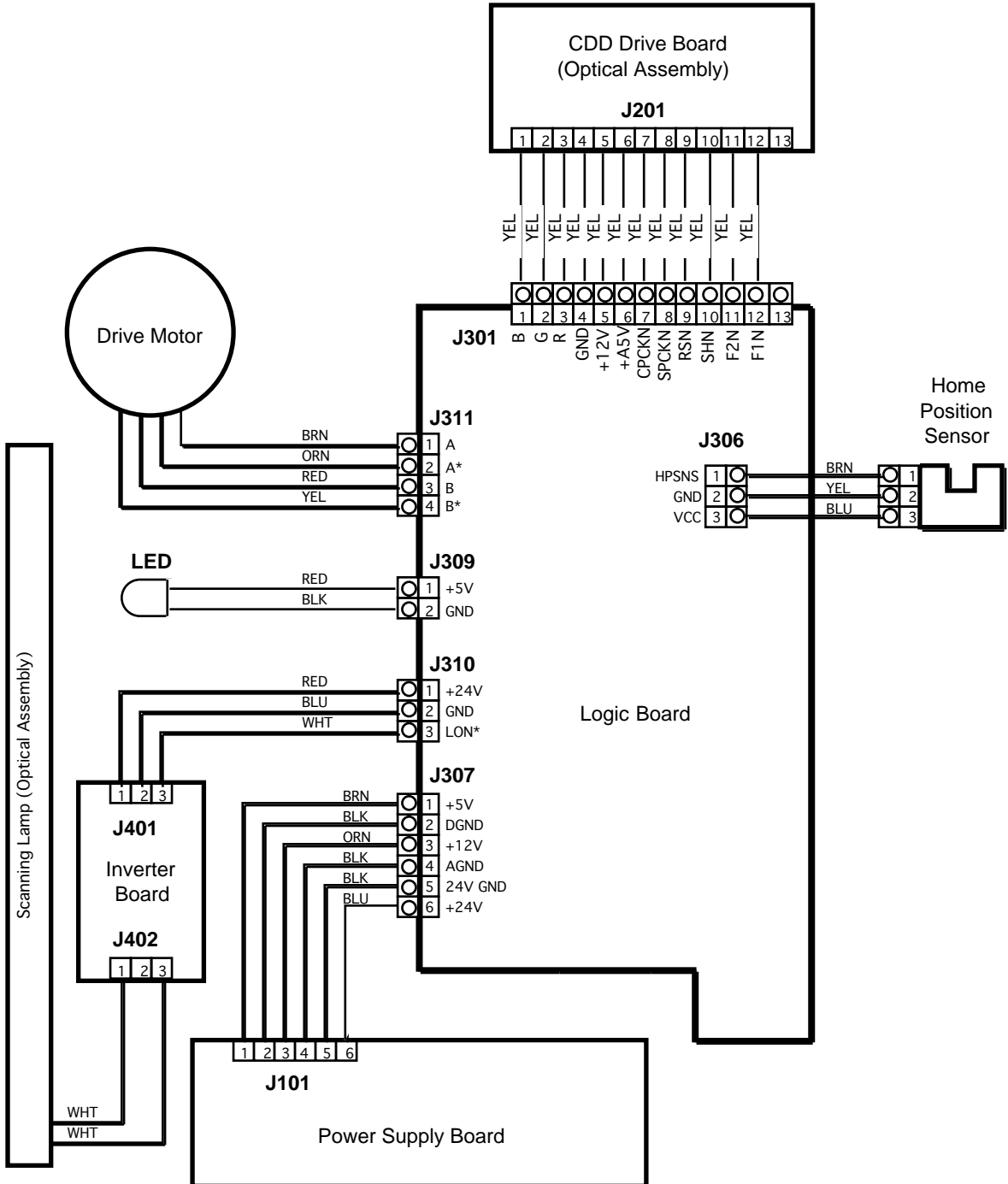



Symptom Charts

Normal Startup Sequence (Flatbed Scanning)

Important: Disconnect the scanner's SCSI cable before beginning the startup sequence. Even when turned off, some computers will not allow the scanner's normal startup sequence to begin if the SCSI cable is connected.

- 1 Power on
- 2 Power LED lights
- 3 Logic board self-tests
- 4 Lamp turns on
- 5 Optical assembly moves to home position sensor at top of glass
- 6 Lamp turns off, then on
- 7 Lamp intensity checked with reflection of white on back of glass
- 8 Origin of scan is determined by black strip on back of glass
- 9 Lamp moves about 3 mm down
- 10 Lamp moves back to home position sensor
- 11 Lamp turns off
- 12 Ready

Startup Troubleshooting Tips

When scanner is turned on, there is a chattering sound and it will not scan.

Unlock the scanner by opening the top cover and using a coin or slotted screwdriver to turn the locking mechanism, located at the top of the glass. **Note:** The arrow that points to the lock or unlock icon is at 90 degrees from the slot. See the Additional Procedures chapter for more information.

When trying to scan from the Dispatch software, this message appears: "Unable to initialize the scanner driver. Either the scanner is not turned on, connected, or already in use by another application."

- 1 The most common cause is that the scanner was turned on after the Macintosh. Always make sure the scanner is turned on, then turn on the Macintosh. Observe the INITs as the Macintosh starts up. The INIT for the scanner appears as a side view of the scanner. This is the driver loading.
- 2 If the scanner INIT does not appear, reinstall the scanner driver. If the icon appears with an "X" through it, there is a SCSI problem.
- 3 Check the SCSI ID and cables.

The SCSI select switch doesn't select the correct SCSI ID.

The label may not be lined up correctly to the position of the switch. Put the switch in the 12 o'clock position and then count to the correct SCSI ID.





General Troubleshooting

No LED (no power)

- 1 Check external power cable and incoming voltage.
- 2 Remove the covers, glass, and optical assembly. Check AC voltage to power supply board by turning power ON and testing for rated AC voltage at the AC input pin (pin L) on the power supply board. If readings are not to rated voltages, replace power supply board.
- 3 With power OFF, reconnect the optical assembly at J301. Turn power ON and check voltages at J101.

J101	DC Voltage
GND-1	4.75 to 5.25
GND-3	11.4 to 12.6
GND-6	21.6 to 26.4

- 4 If any voltages are not correct, replace the power supply board.
- 5 Turn scanner off. With power OFF, remove connector J301 from the logic board. Turn power ON and check the voltages at J101 again. If readings are within specified ranges, replace the optical assembly, since the CCD driver is faulty.
- 6 Turn scanner OFF and reconnect J301.
- 7 With power OFF, remove connector J311 from the logic board. Turn power ON and check the voltages at J101 again. If readings are within specified ranges, replace the drive motor.
- 8 Turn scanner OFF and reconnect J311.
- 9 With power OFF, remove connector J306 from the logic board.
- 10 Turn power ON and check voltages at J101 again. If readings are within specified ranges, replace the home position sensor and/or home position sensor cable.
- 11 Turn scanner OFF and reconnect J306.
- 12 With power OFF, remove connector J309 from the logic board.
- 13 Turn power ON and check voltages at J101 again. If readings are within specified ranges, replace the LED cable. If readings are not within specified ranges, replace the logic board.
- 14 Turn scanner OFF and reconnect J309.





Lamp does not light

- 1 Check connection at J402.
- 2 Remove the covers, glass, and optical assembly. With power OFF, reconnect the optical assembly at J301. Turn power ON and check voltages at J101.

J101	DC Voltage
GND-1	4.75 to 5.25
GND-3	11.4 to 12.6
GND-6	21.6 to 26.4

- 3 If any voltage is not correct, replace power supply board.
- 4 Connect J310 pin 2 to ground. Verify that scanner lamp lights. If lamp does not light, replace logic board.
- 5 Connect J402 pin 2 on inverter board to ground. Verify that scanner lamp lights. If lamp does not light, replace inverter board. If lamp lights, replace optical assembly.

Lamp turns on, but scanner drive motor is not working

- 1 Make sure scanner optical assembly is unlocked. See Additional Procedures chapter for information.
- 2 Check connections at J307 and J311.
- 3 Remove optical assembly and turn on scanner. If motor works, make sure the glass is oriented correctly. Go to symptom “Scanner does not find Home sensor”.
- 4 With scanner on, check voltages at connector J101.

J101	DC Voltage
GND-1	4.75 to 5.25
GND-3	11.4 to 12.6
GND-6	21.6 to 26.4

- 5 If any voltages are not correct, go to symptom “No LED, no power” in this chapter.
- 6 Turn power off and check resistance in the drive motor by measuring at connector J311.

J311 pins	Resistance
1 and 2	about 17.3 ohms
3 and 4	about 17.3 ohms

- 7 If resistance is not correct, replace drive motor. If resistance is correct, check connection at J311 and if it is normal, replace logic board.





Problem with lamp intensity checked or origin of scan area	<ol style="list-style-type: none">1 Make sure glass is oriented correctly and that nothing is blocking the black strip or upper portion of the glass.2 Replace glass.
Scanner does not find Home sensor; scanner drive motor does not move mirror, even when optical assembly is removed	<ol style="list-style-type: none">1 Inspect mirror assembly on optical assembly for damage to the home position flag. Replace optical assembly if needed.2 Replace home sensor (photo-interrupter).3 Replace logic board.
When the Apple Color OneScanner Plug-in is moved to the Photoshop Acquire folder it doesn't work. The Dispatch doesn't work either.	The Apple Color OneScanner Plug-in must be left in it's folder. You can make a copy of it, or an alias and put that in the Acquire folder. You cannot change the name of the original plug-in. It must keep the name "Apple Color OneScanner".
When using the Automatic Document Feeder (ADF), the scan shows a blank page or a strange vertical pattern.	Check to see if paper has been left on the flatbed. Before using the ADF, always check to see that the flatbed is empty.
Cannot fax multiple pages with the ADF.	Scan each page and merge them together before faxing them.
ADF does not feed paper to scanner	<ol style="list-style-type: none">1 Check connection at document feeder connector cable.2 Close document feeder cover completely.3 Verify that document originals in the feeder are standard office papers and do not exceed the maximum thickness of 2 mm (5/64 in) or 20 sheets.4 Verify that document originals are free from<ul style="list-style-type: none">• Tears, perforations, or punch holes• Curls or wrinkles• Carbon backing or coarse texture• Labels, tape, or glue• Staples or clips5 Replace logic board.





Image Defects

Image not correct, white only, black only, or grey.

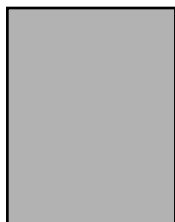
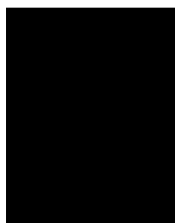

- 1 Check SCSI cable connection.
- 2 Check whether scanning lamp is lighting. If not, go to symptom “Lamp does not light” in this chapter.
- 3 With power off, remove connector J307. Turn on power and check voltages at J101 on the power supply board.

J101	DC Voltage
GND-1	4.75 to 5.25
GND-3	11.4 to 12.6
GND-6	20.4 to 27.6

- 4 If these voltages are not present, go to symptom “No LED (no power)” in this chapter.
- 5 Replace logic board.
- 6 Check connector at J301 and if it is normal, replace optical assembly.





Image blurred

- 1 Use a soft, dry cloth to clean top of glass.
- 2 Check mirror for dust or obstructions.
- 3 Replace optical assembly.

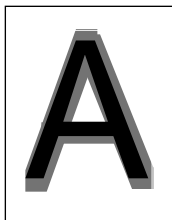



Uneven image density or lines (horizontal)

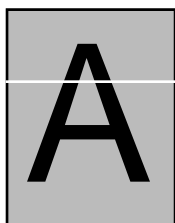
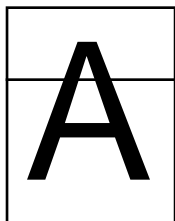
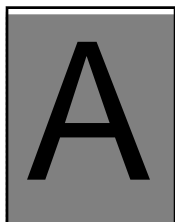

- 1 Use a soft, dry cloth to clean top of glass.
- 2 Check underside of glass to make sure the white plate is intact.
- 3 Check connections at J301 and J310 on the logic board.
- 4 Replace logic board.
- 5 Replace optical assembly.





Uneven image density or lines (vertical)

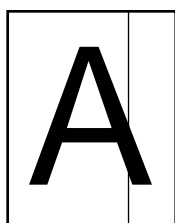
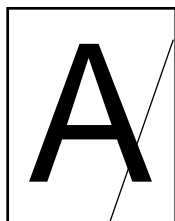
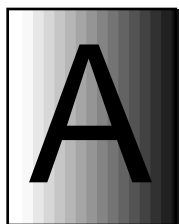

- 1 Use a soft, dry cloth to clean top of glass.
- 2 Check underside of glass to make sure the white plate is intact.
- 3 Check mirrors for dust or obstructions.
- 4 Replace logic board.
- 5 Replace optical assembly.





Image is misaligned
(vertical)

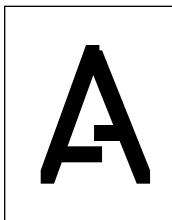

- 1 Make sure the mirror on the optical assembly is not obstructed.
- 2 Replace optical assembly.





Image is distorted

- 1 Replace optical assembly.
- 2 Replace logic board.

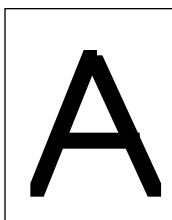
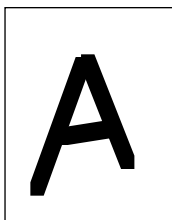
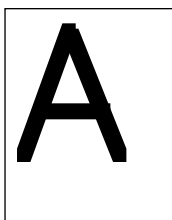



Take Apart

Color OneScanner 600/27





Top Cover with Hinge

No preliminary steps are required before you begin this procedure.





Lift the top cover straight off the scanner.

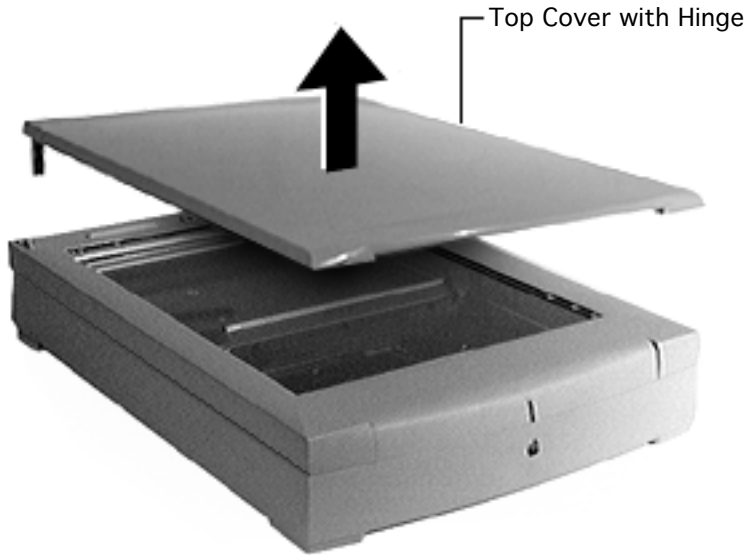



Glass Cover

Before you begin, remove the top cover with hinge.

Caution: Review the ESD precautions in Bulletins/Safety.

Glass Cover

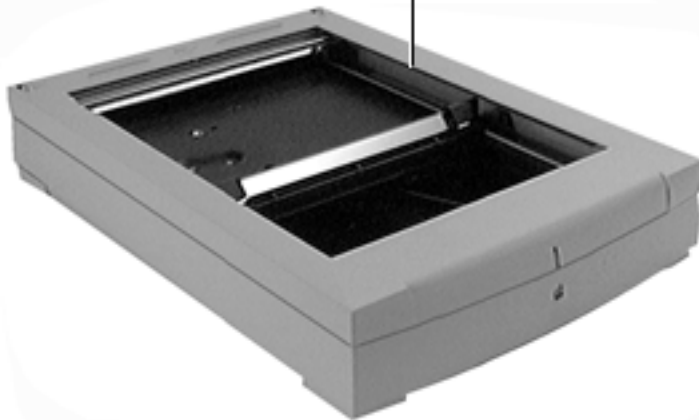

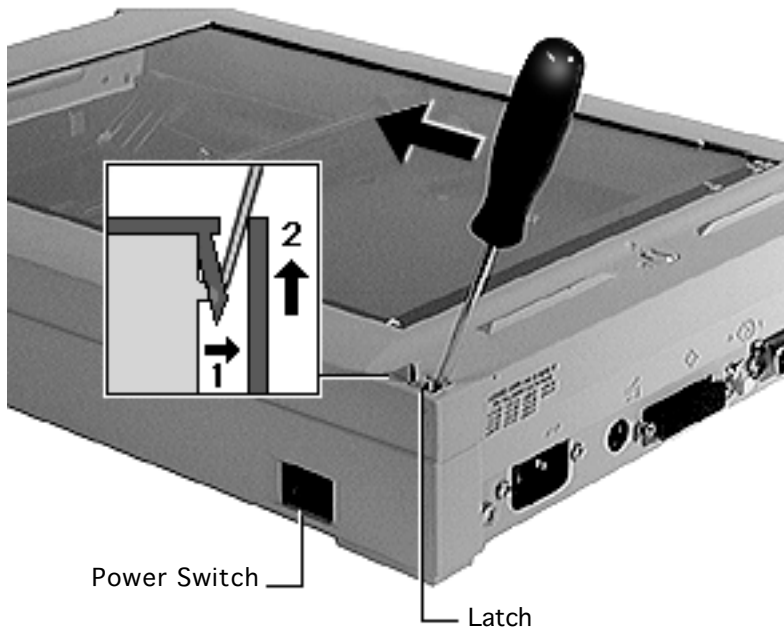

- 1 Using a jeweler's flat-blade screwdriver, release the two glass cover latches.
- 2 While pressing the power switch, carefully lift off the glass cover.

Caution: When removing the glass cover assembly, make sure you don't damage the LED cable.



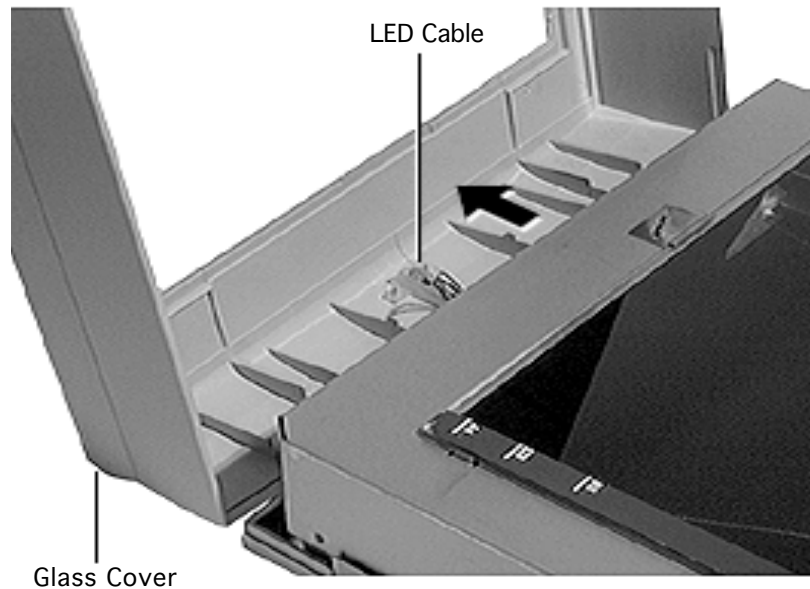

- 3 Raise the glass cover assembly to 90 degrees and disconnect the LED cable by pushing the LED toward the top of the glass cover.
- 4 Remove the glass cover from the scanner.

Caution: When the glass cover is removed, do not tilt the scanner on its side, or the glass may slip off.



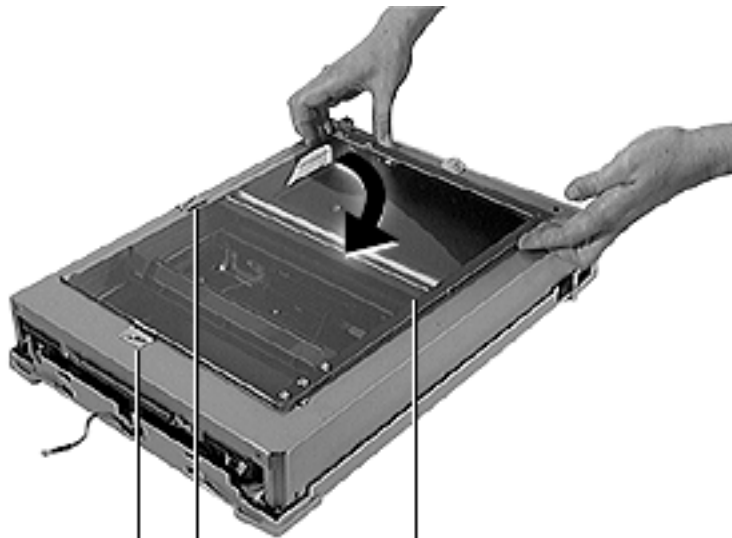

Glass Holder
Clip

Glass Holder
Clip

Glass

- 5 Grasp the glass by its edges, and taking care not to bend the glass holder clips, slightly lift the glass and rotate it clockwise to release it from the glass holder clips.

Handle the glass by its edges and place it in a clean area.





Optical Assembly

Before you begin, remove the following:

- Top cover with hinge
- Glass cover assembly

Caution: Review the ESD precautions in Bulletins/ Safety.

- 1 Make sure
 - Scanner power is off
 - Power cord is connected
 - SCSI cable is disconnected

Optical Assembly

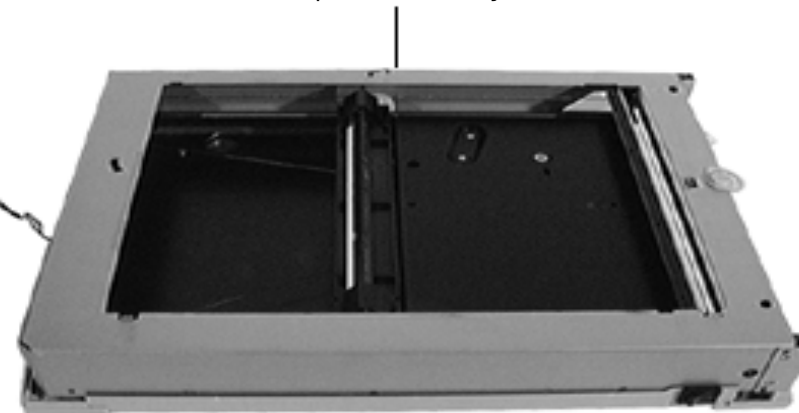

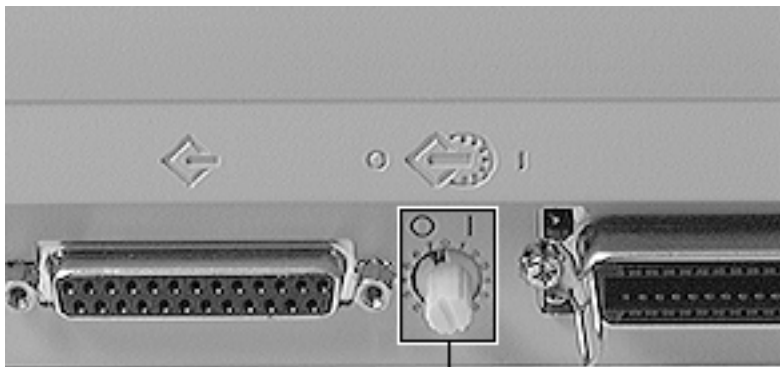

SCSI ID Switch



- 2 Set the SCSI ID switch to 7 (terminator off position).
- 3 Switch on the scanner power.

Wait for the startup sequence to finish and the lamp to turn off. (For a description of the normal startup sequence, refer to the Troubleshooting chapter.)
- 4 Set the SCSI ID switch to 0 (terminator on position).



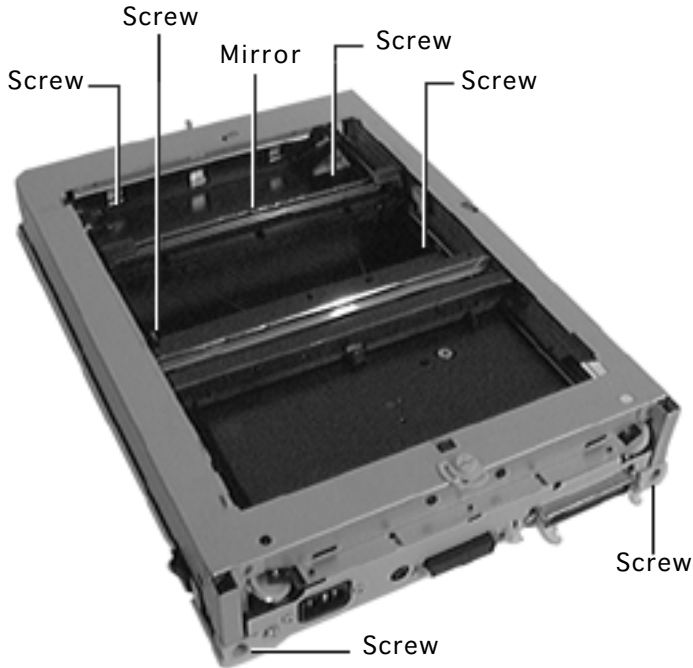

- 5 Set the SCSI ID switch back to 7, then back to 0 and finally back to 7.
- 6 After about 10 seconds, the lamp and mirror will move. When the mirror has reached the position shown, turn off the scanner.
- 7 Using a Phillips screwdriver, remove
 - Four screws and lockwashers
 - Two screws at rear feet



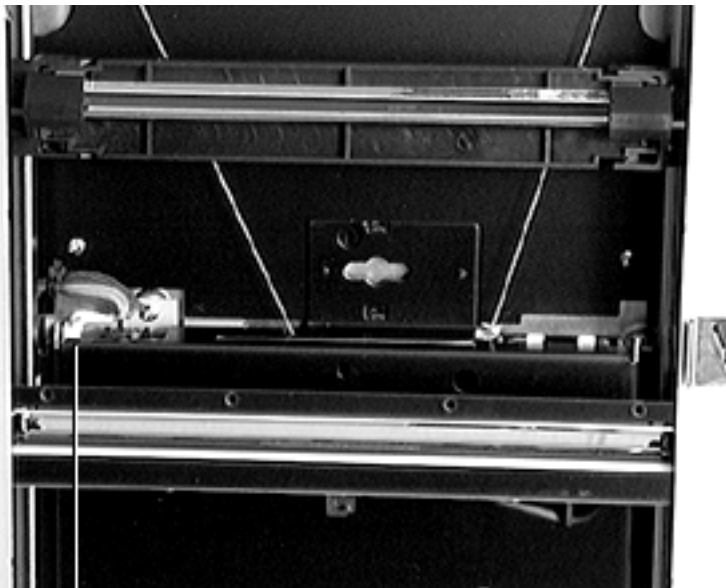

J402

- 8 Using a needlenose pliers, carefully remove connector J402 from the logic board.



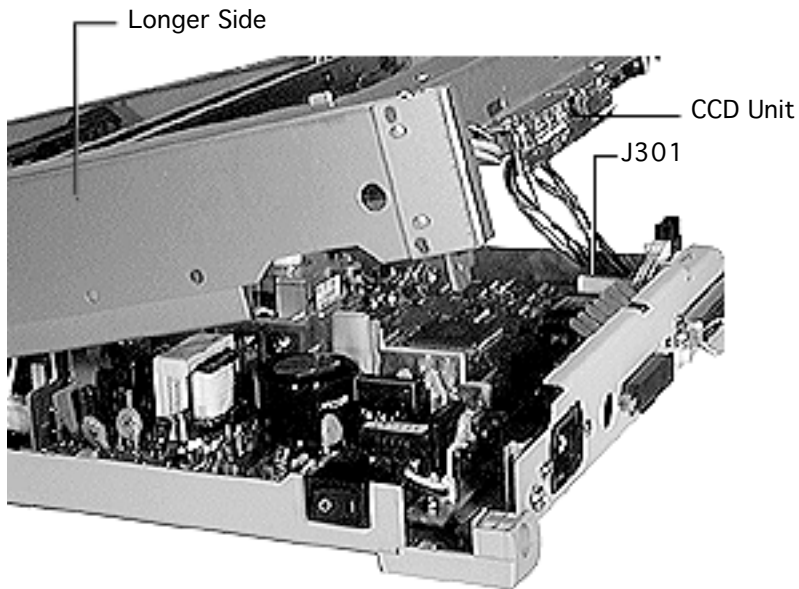

- Carefully lift the optical assembly and remove connector J301 from the inverter board.

Caution: Handle the scanner assembly by the longer sides so that the printed circuit board (CCD unit) on the underside will not be damaged.



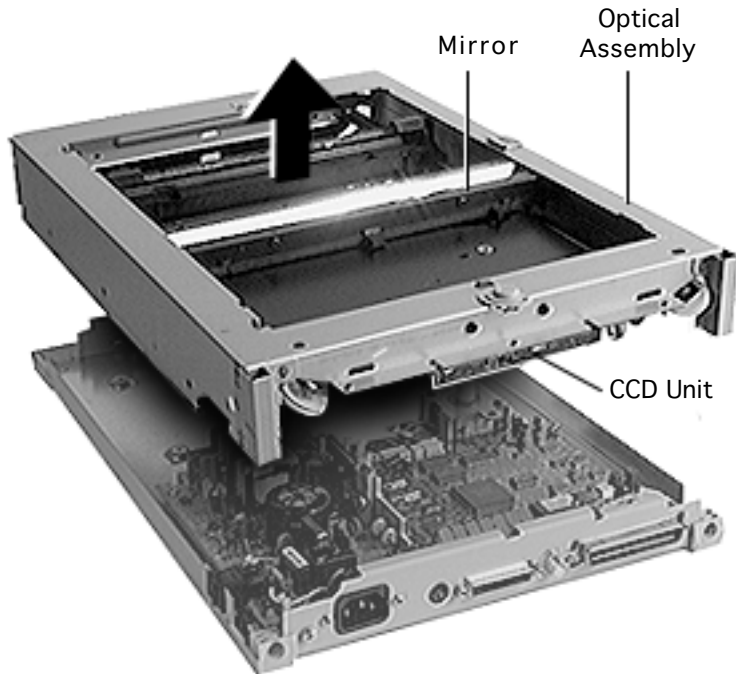

10 **Note:** Do not touch the mirror or the printed circuit board (CCD unit) on the optical assembly.

Remove the optical assembly from the scanner.





LED Cable

Before you begin, remove the following:

- Top cover
- Glass cover assembly
- Optical assembly

Caution: Review the ESD precautions in Bulletins/ Safety.

LED Cable

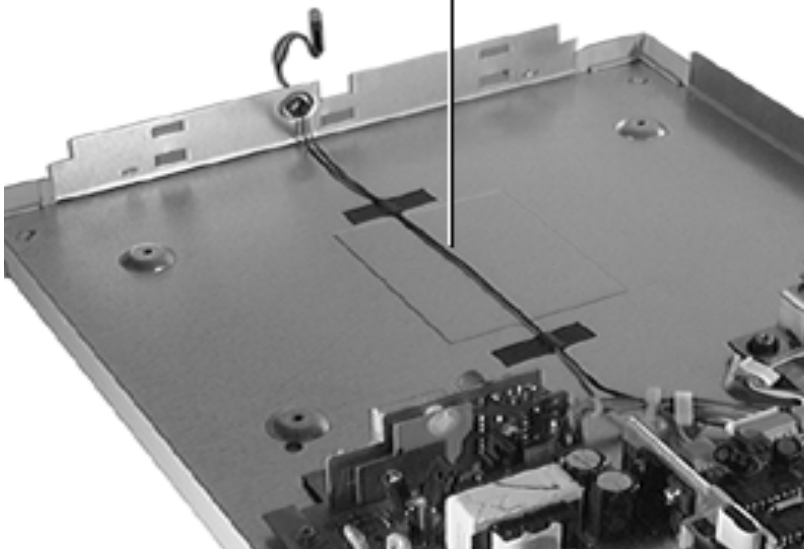

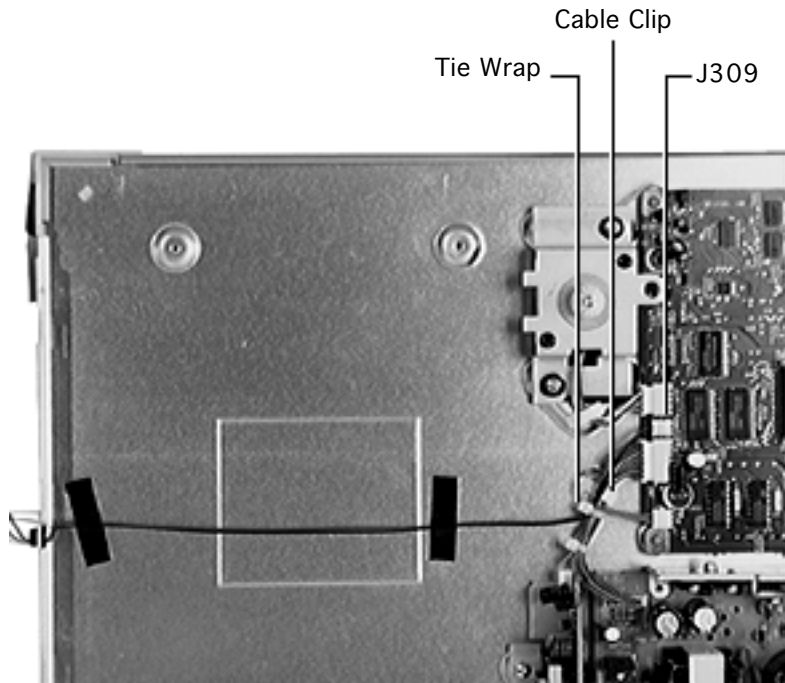

- 1 Disconnect connector J309 from the logic board.
- 2 Remove the cable from the cable clip and cut the tie wrap.





- 3 Remove the tape and LED cable from the bottom case.

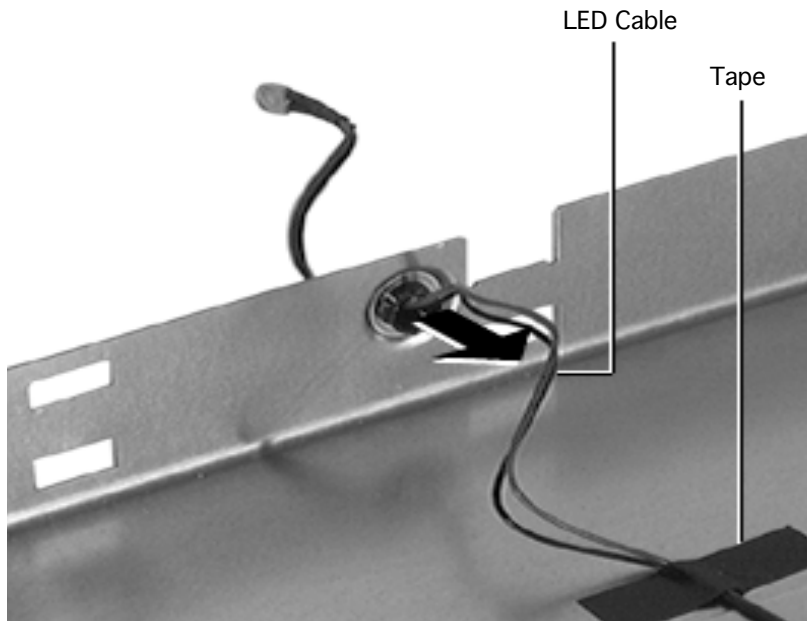



Inverter Board

Before you begin, remove the following:

- Top cover
- Glass cover assembly
- Optical assembly

Caution: Review the ESD precautions in Bulletins/ Safety.

Inverter Board

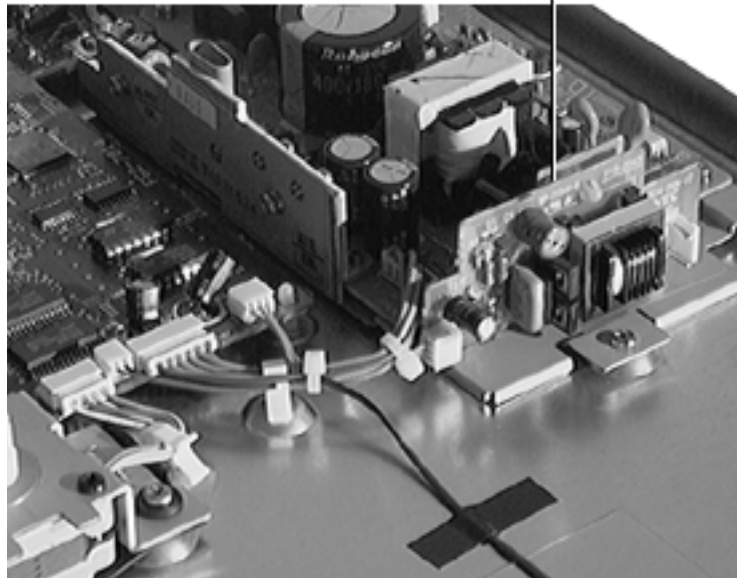



- 1 Disconnect connector J402 from the inverter board.

J402

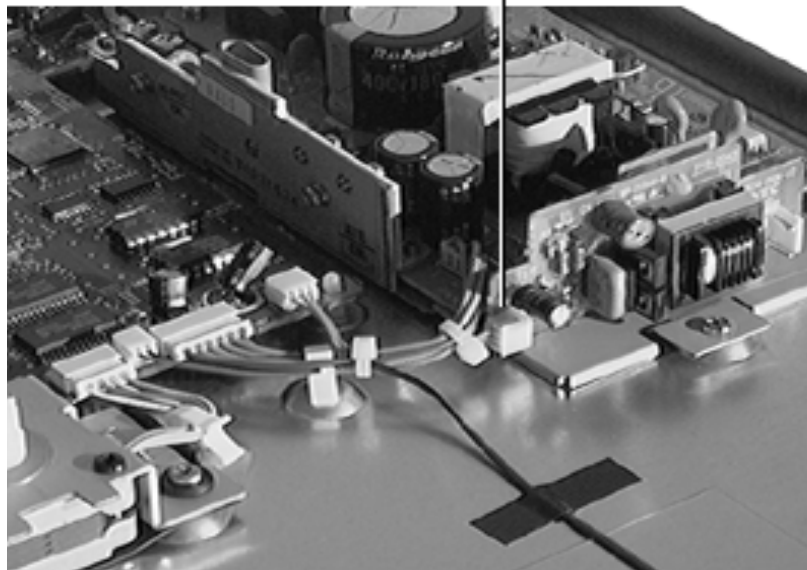



- 2 Using a pair of needlenose pliers, squeeze the card spacer tabs and remove the inverter board.

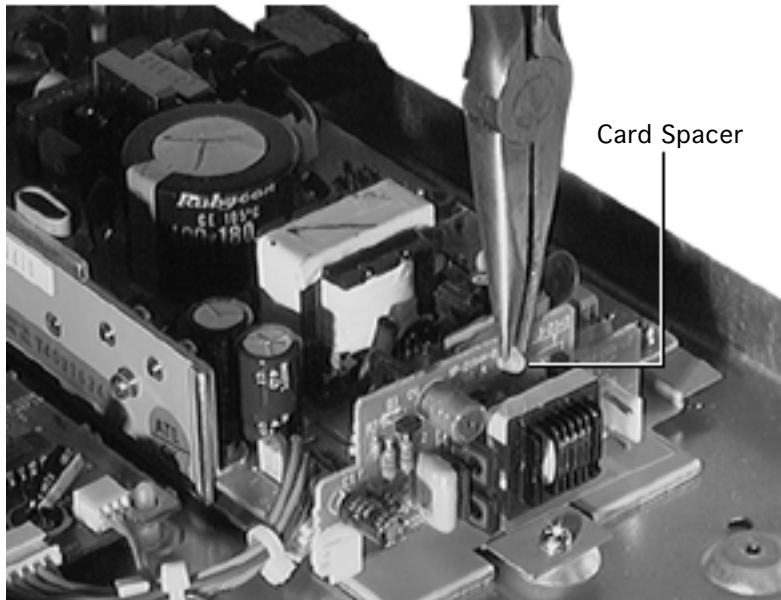



Drive Motor and Bracket

Before you begin, remove the following:

- Top cover
- Glass cover assembly
- Optical assembly

Caution: Review the ESD precautions in Bulletins/ Safety.

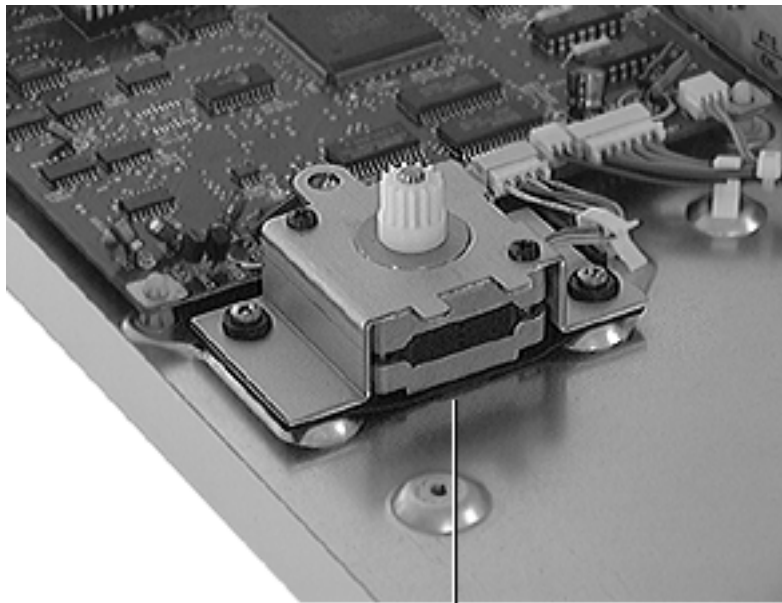

Drive Motor





- 1 Remove connector J311 from the logic board.
- 2 Remove the cable from the cable clip.

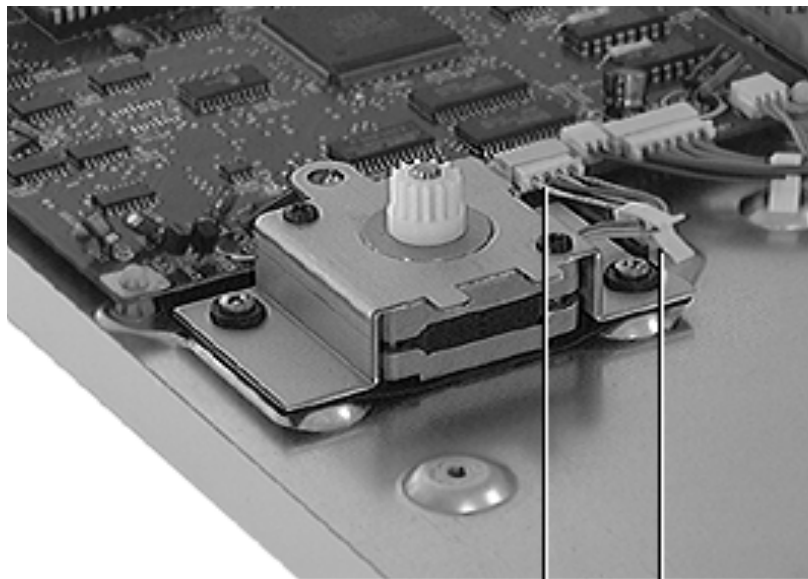

J311

Cable Clip





- 3 Remove the two screws and washers.
- 4 Remove the drive motor and bracket from the bottom case.

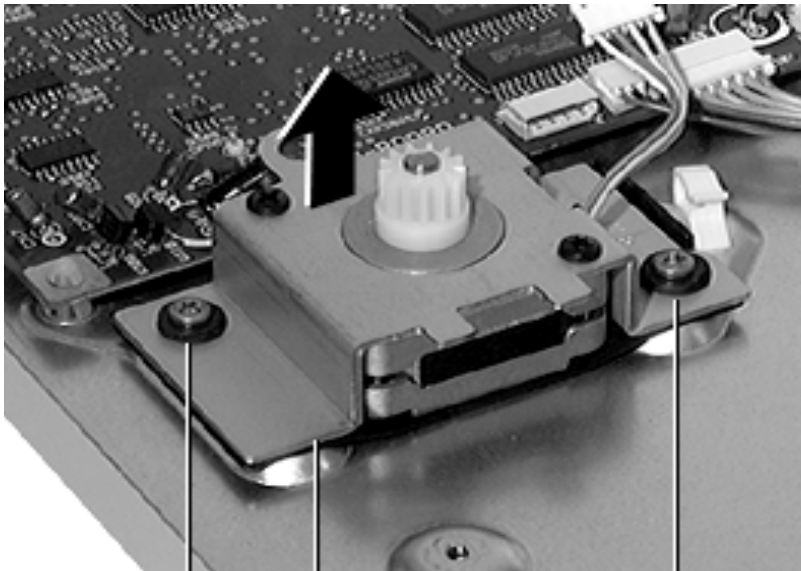

Screw

Drive Motor

Screw



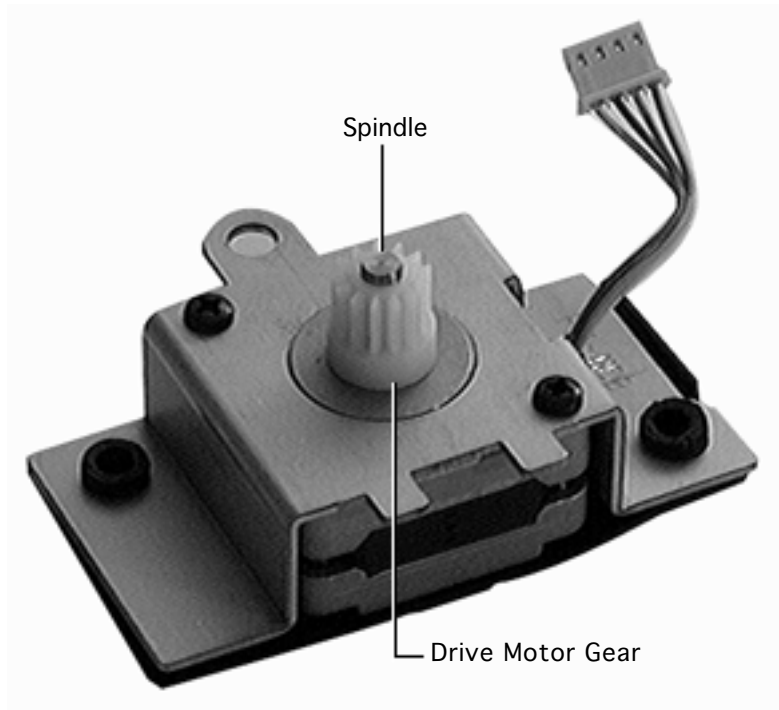

- 5 If necessary, lift off and remove the gear from the motor.

Replacement Note: Make sure the gear is lined up with the flat side of the drive motor spindle when reinstalling.



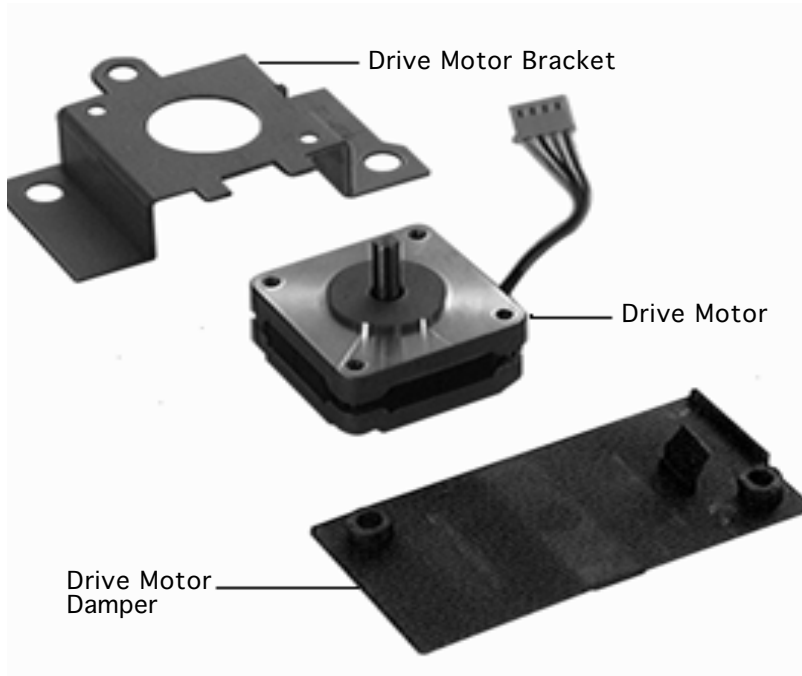

- 6 Carefully remove the drive motor damper.
- 7 Using a Phillips screwdriver, remove the two screws from the drive motor bracket.
- 8 Remove the drive motor from the bracket.





Power Supply Board

Before you begin, remove the following:

- Top cover
- Glass cover assembly
- Optical assembly
- Inverter board

Caution: Review the ESD precautions in Bulletins/ Safety.

Note: Remove the inverter board before returning the power supply to Apple.

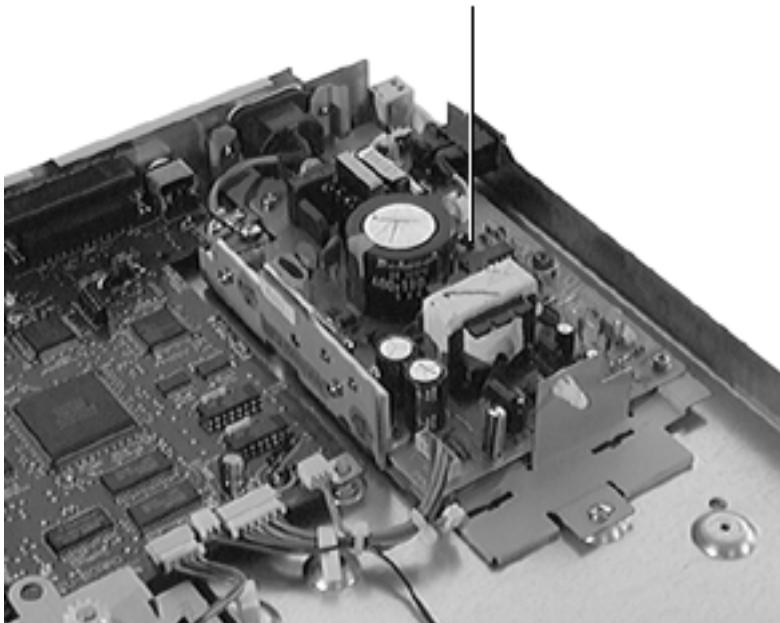

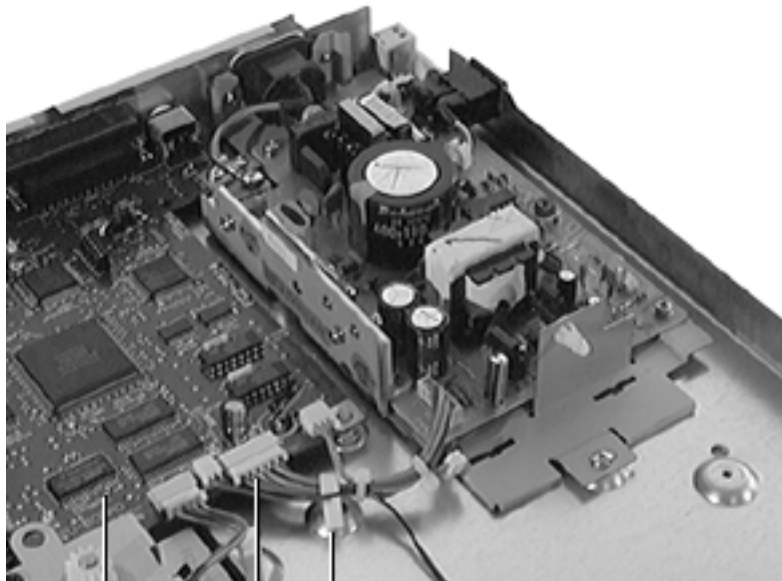

Logic Board J307 Cable Clip

- 1 Cut the tie wraps and remove connector J307 from the logic board.
- 2 Remove the cables from the cable clip.





- 3 Slide the power switch up and out of the bottom case.
- 4 Remove the two screws that hold the power receptacle.

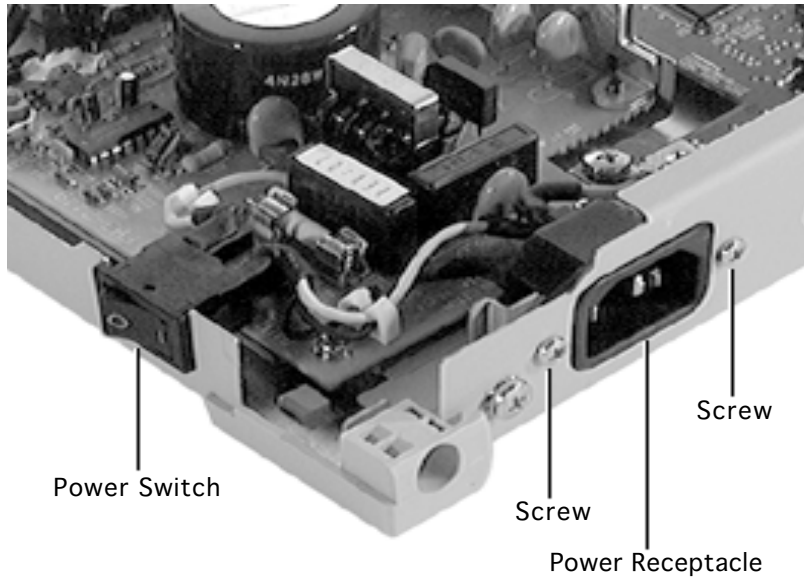

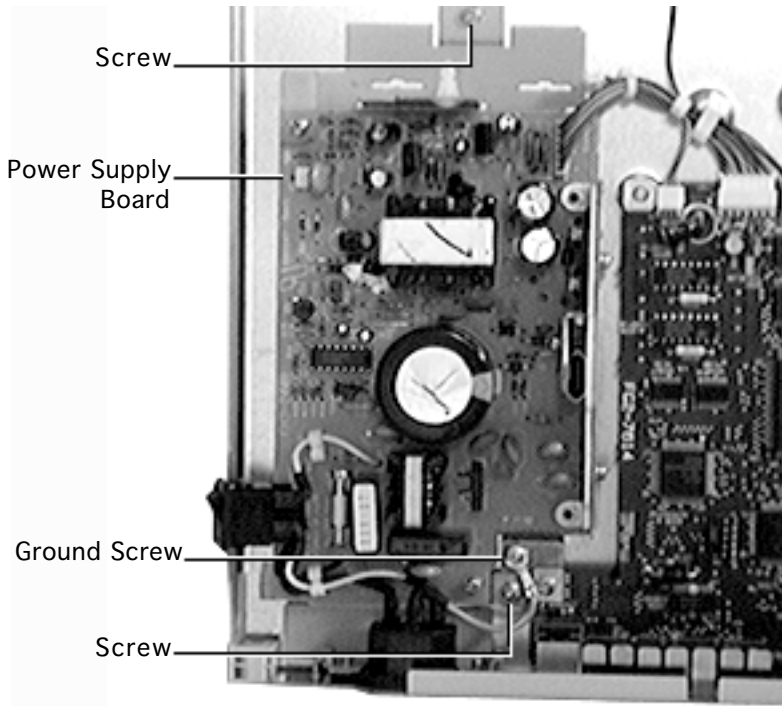

- 5 Remove the two mounting screws.
- 6 Remove the ground screw and lockwasher.
- 7 Remove the power supply board from the scanner.





Logic Board

Before you begin, remove the following:

- Top cover
- Glass cover assembly
- Optical assembly
- Drive Motor

Caution: Review the ESD precautions in Bulletins/ Safety.

Logic Board

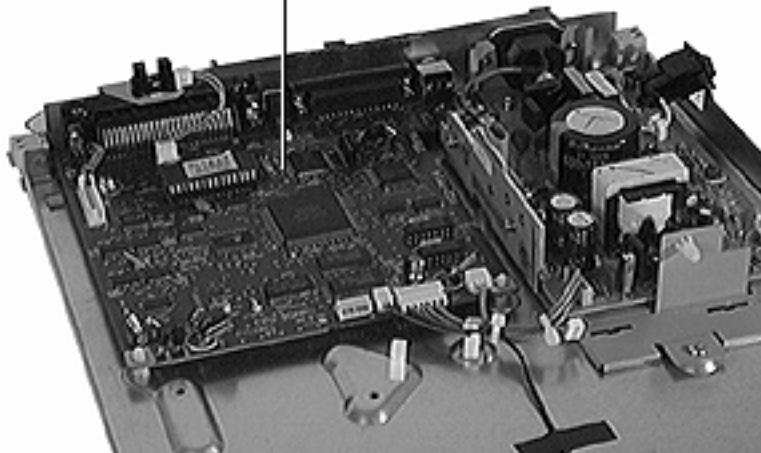

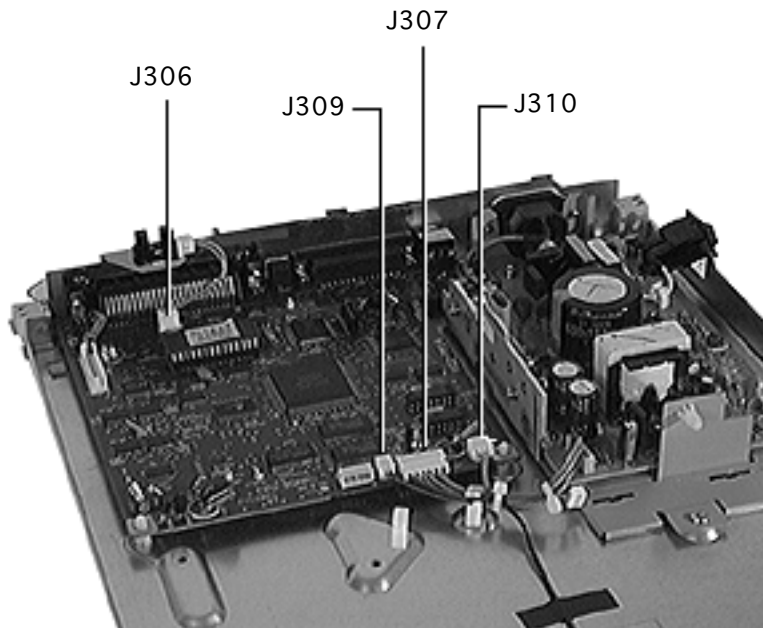

1 Disconnect the following cables from the logic board:

- J306
- J307
- J309
- J310



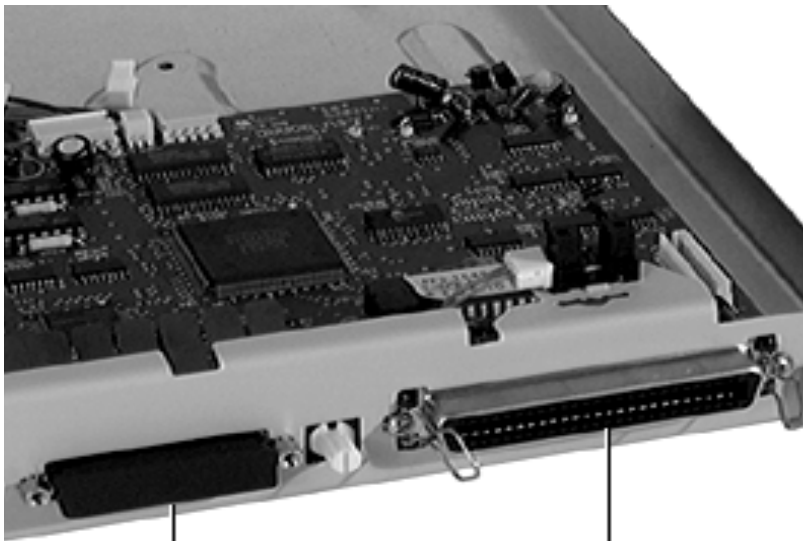

Interface Connector

SCSI Connector

- 2 Using a Phillips screwdriver, remove the two mounting screws from the SCSI connector.
- 3 Using a hex driver, remove the two mounting screws from the interface connector.



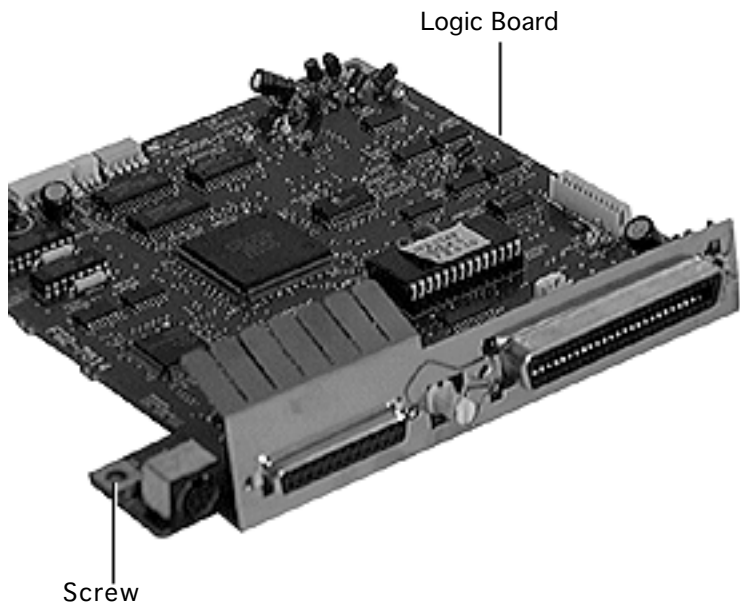

- 4 Remove the corner screw from the logic board.





- 5 Using needlenose pliers, squeeze together the card spacers and lift off the logic board.

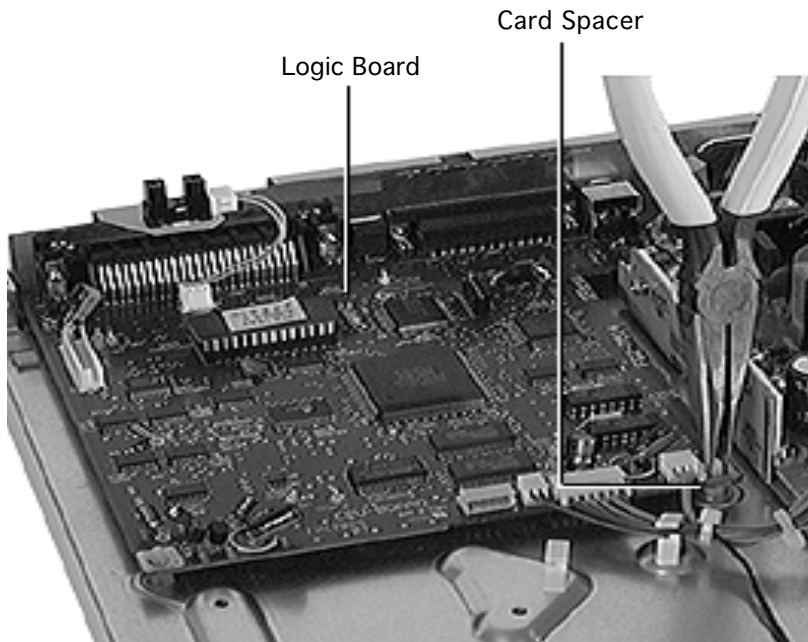

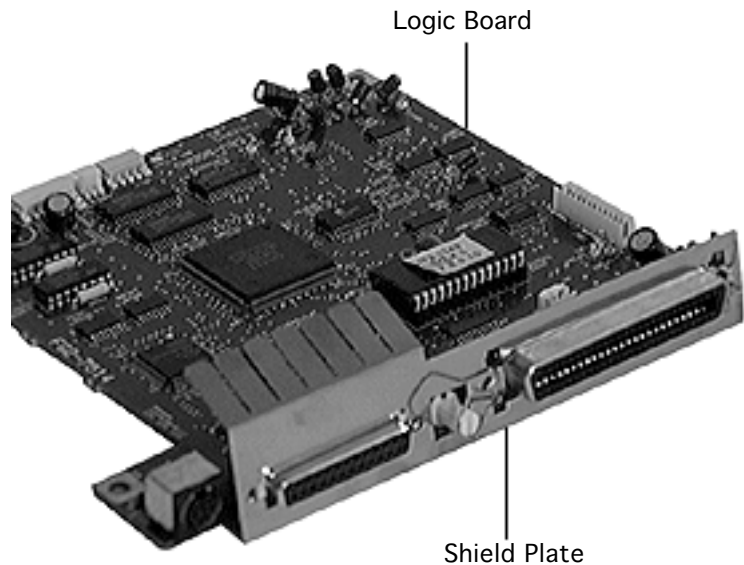

- 6 Remove the shield plate from the logic board.





Home Position Sensor (Photo-Interrupter) and Cable

Before you begin, remove the following:

- Top cover
- Glass cover assembly
- Optical assembly

Caution: Review the ESD precautions in Bulletins/ Safety.

Home Position Sensor
(Photo-Interrupter)

Cable

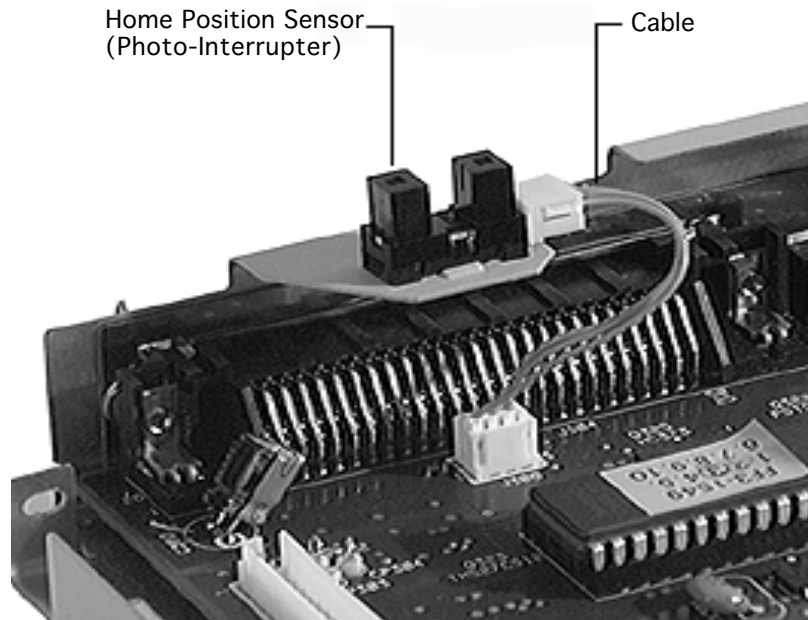



- 1 Remove the cable from connector J306 on the logic board and the connector on the home position sensor (photo-interrupter).

Home Position Sensor

Cable

Logic Board





- 2 Press in the two latches and lift up to remove the home position sensor from the bottom case.

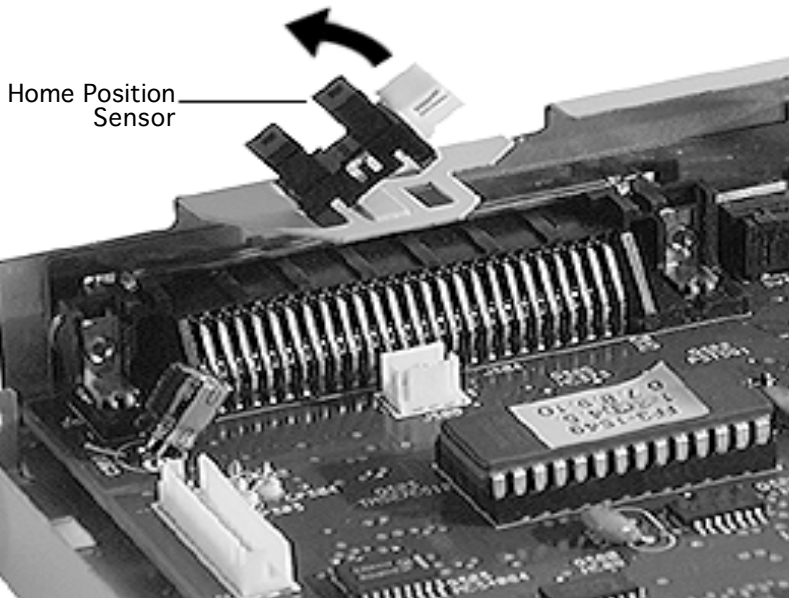

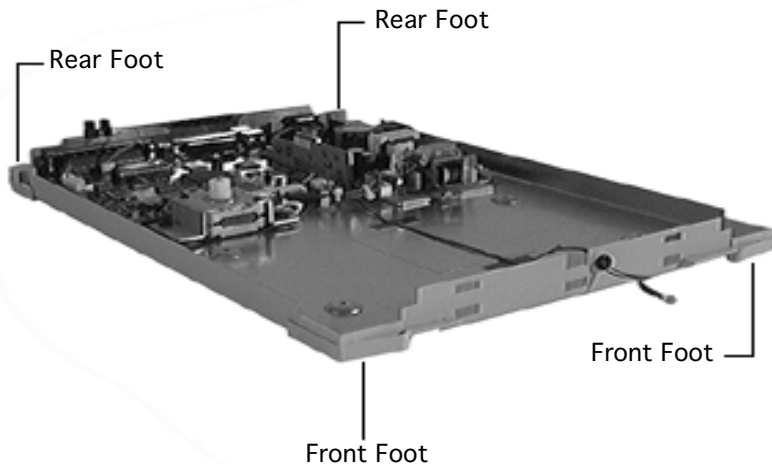

Feet

Before you begin, remove the following:

- Top cover
- Glass cover assembly
- Optical assembly

Caution: Review the ESD precautions in Bulletins/Safety.





- 1 Slide the rear foot off of the bottom case. Repeat for other rear foot.

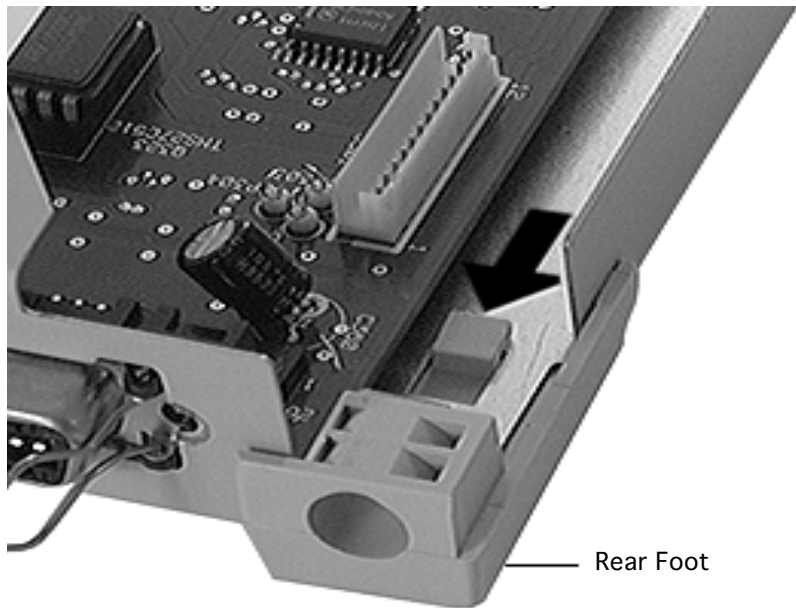

Rear Foot





- 2 Press down and unlatch the front foot from the bottom case. Repeat for other front foot.

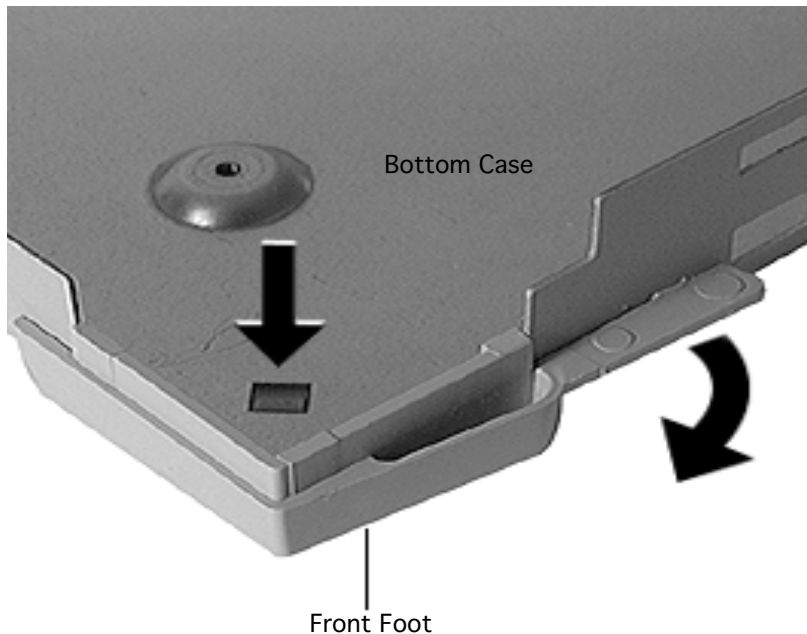



Automatic Document Feeder



Automatic Document Feeder

No preliminary steps are required before you begin this procedure.

Caution: Review the ESD precautions in Bulletins/ Safety.



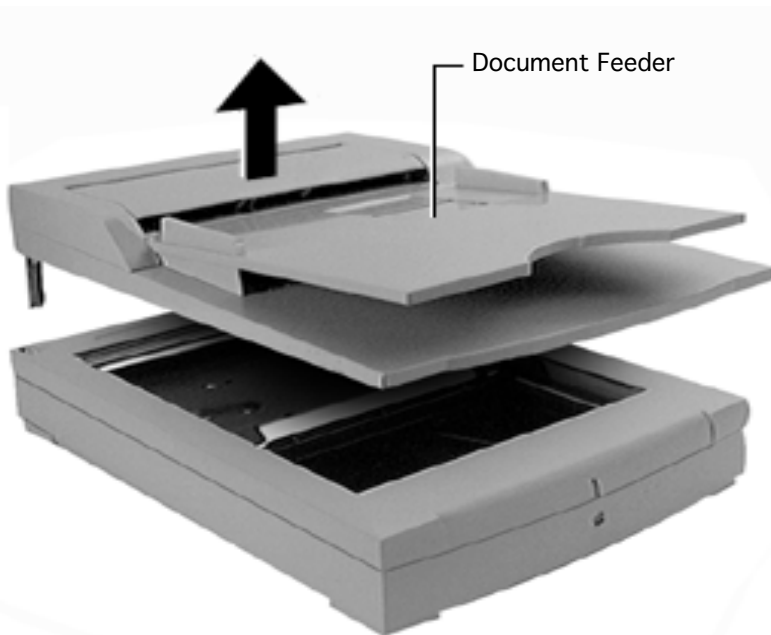

- 1 Lift the document feeder straight off the scanner.





Paper Separator

- 1 Lift up the top cover of the document feeder.

Document Feeder Top Cover

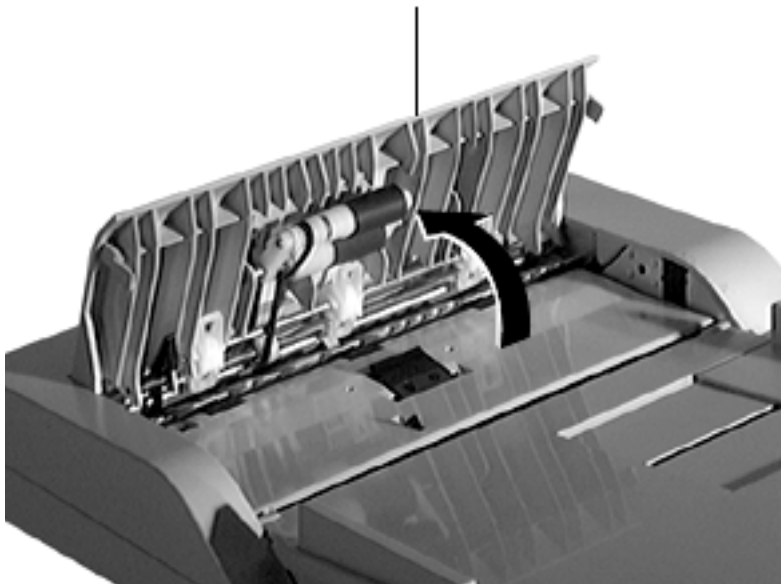

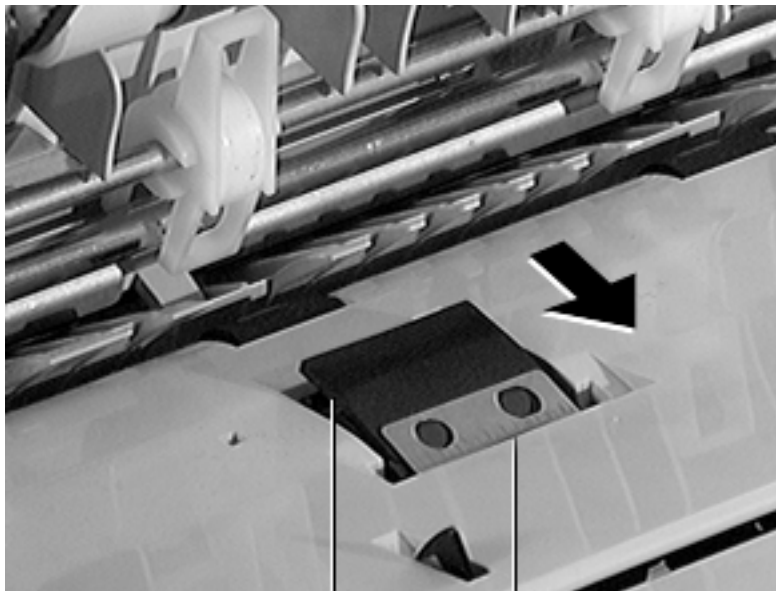

Rubber Piece

Paper Separator

- 2 Do not pull on the rubber piece on the paper separator. It is held in place by a metal clip and will come off if pulled.

Push down and press forward on the paper separator.

- 3 Remove the paper separator.



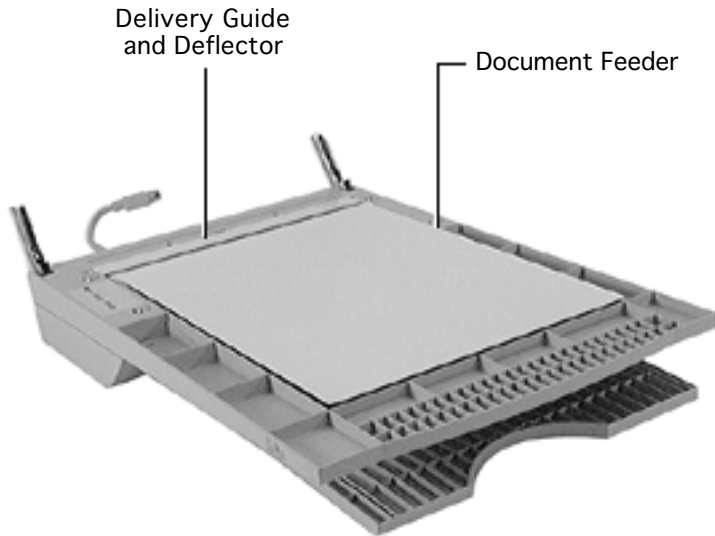

Delivery Guide and Deflector

- 1 Turn the document feeder over.



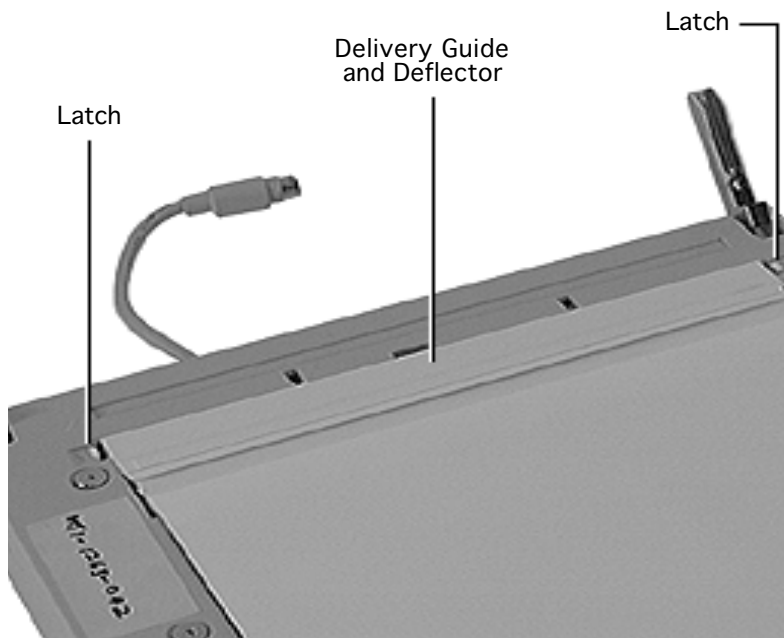

- 2 Press in the two latches and swing out the delivery guide and deflector.





- 3 Remove the delivery guide and deflector.

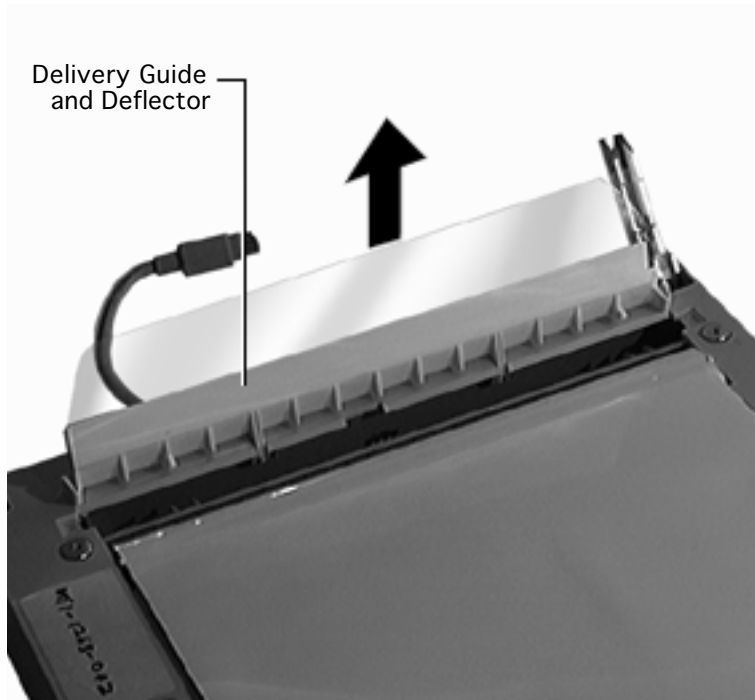



- 4 Remove the delivery guide from the deflector.

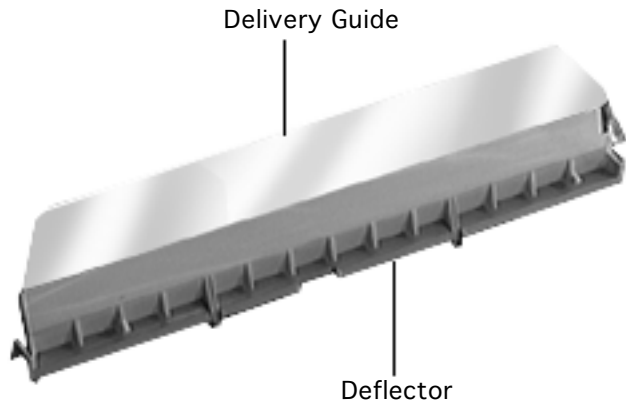

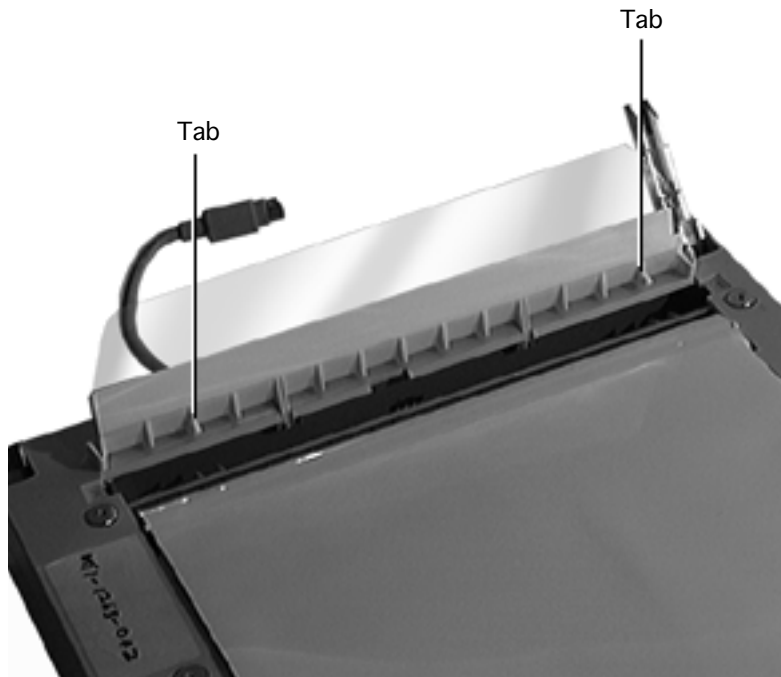

Replacement Note:

Before installing the deflector back into the document feeder, make sure the two holes on the delivery guide line up with the two tabs on the deflector.





Plastic Sheet

Delivery Guide

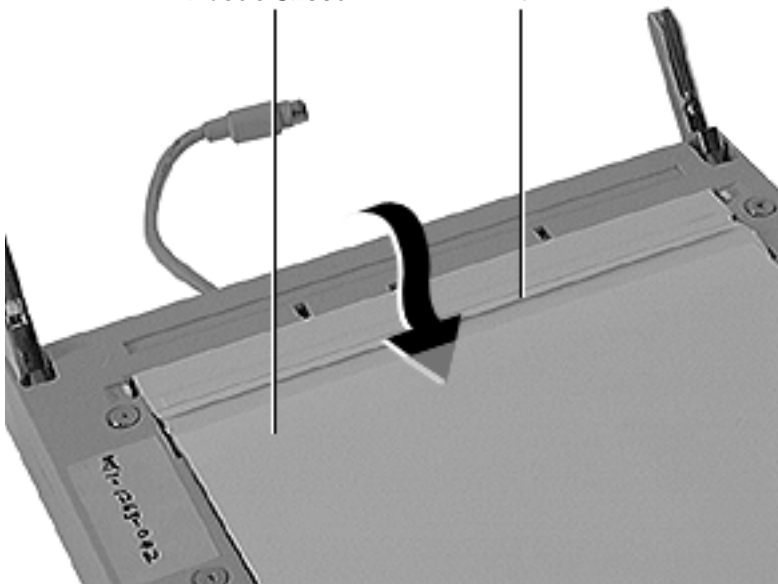

Replacement Note: Slip the delivery guide back under the plastic sheet on the document feeder and snap the deflector in place.





Additional Procedures

Color OneScanner 600/27





Unlocking the Scanner

Before you begin, remove the top cover with hinge.





Using a coin or a flat-blade screwdriver, rotate the lock to the unlocked position.

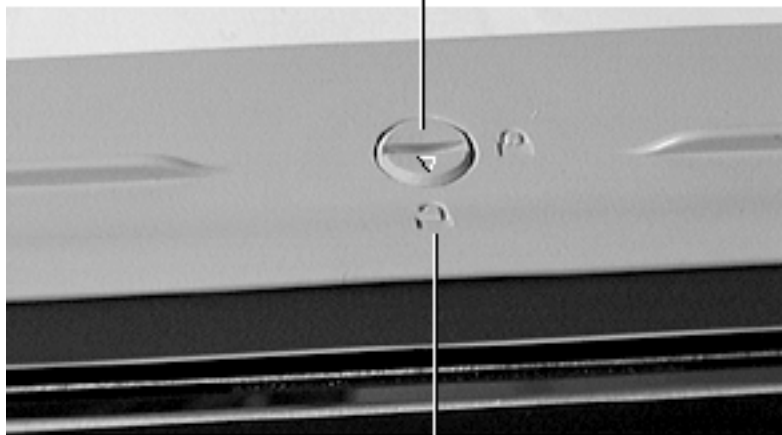

Lock

Unlocked
Position





Changing the SCSI ID

No preliminary steps are required before you begin this procedure.

Caution: Review the ESD precautions in Bulletins/ Safety.



SCSI Switch



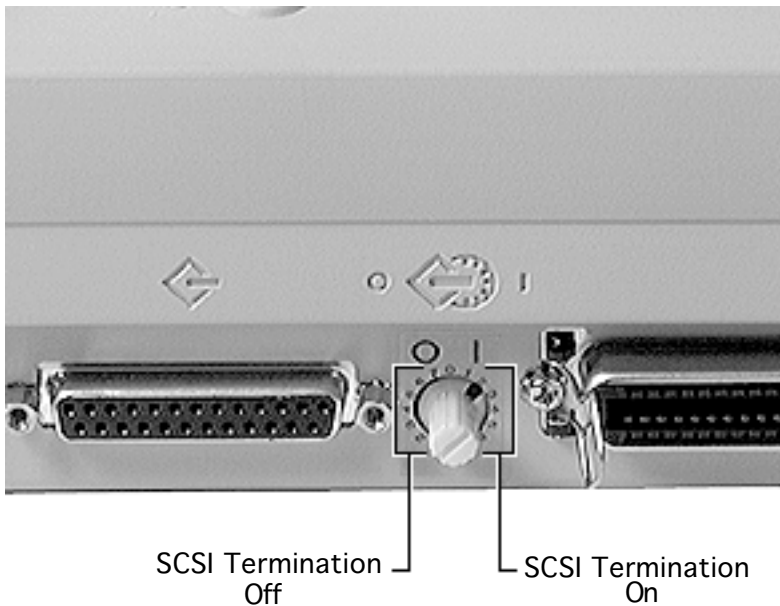

There are two sets of SCSI ID numbers, depending if the scanner has an external SCSI terminator installed:

- The numbers on the left are with SCSI termination turned off. Use these numbers if there is an external SCSI terminator.
- The numbers on the right are with SCSI termination turned on. Use these numbers if there is no external terminator.



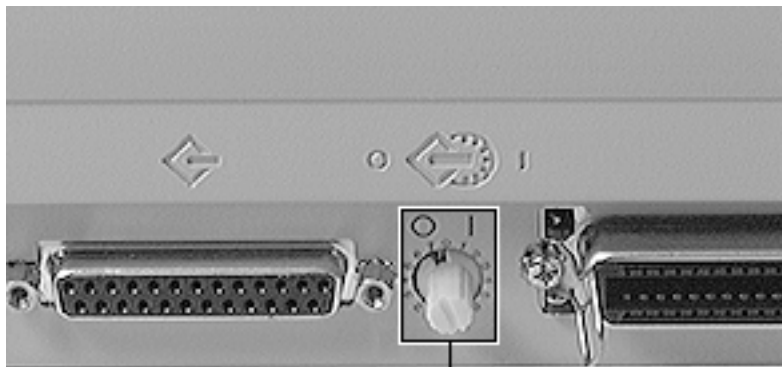

Turn the switch to the desired number.

SCSI ID Switch





Optical Assembly

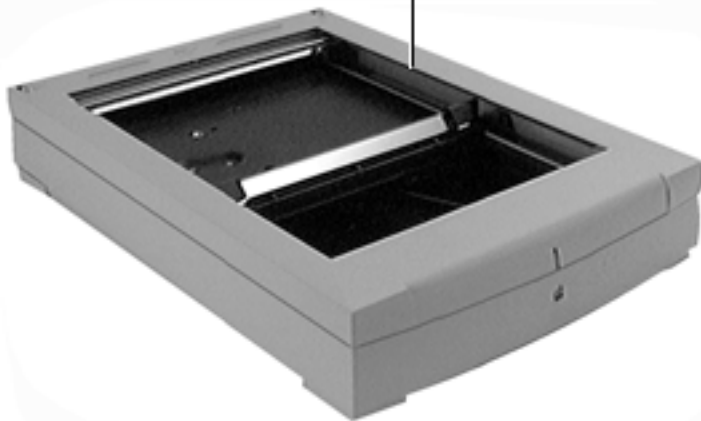

Moving the Optical Assembly to Service Position

Before you begin, remove the top cover with hinge.

- 1 Make sure
 - Scanner power is off
 - Power cord is connected
 - SCSI cable is disconnected



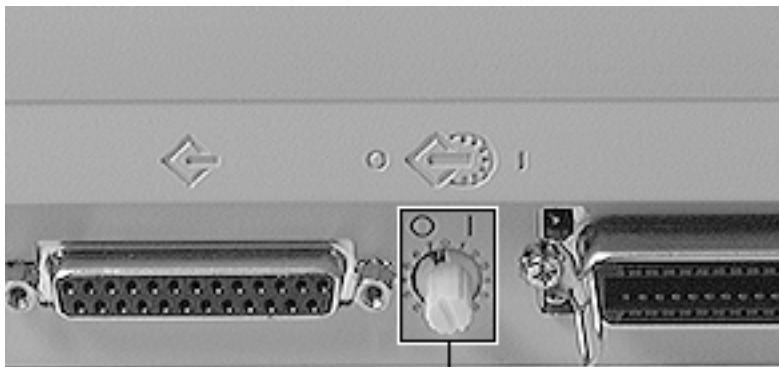

SCSI ID Switch



- 2 Set the SCSI ID switch to 7 (terminator off position).
- 3 Switch on the scanner power.

Wait for the startup sequence to finish and the lamp to turn off. (For a description of the normal startup sequence, refer to the Troubleshooting chapter.)

- 4 Set the SCSI ID switch to 0 (terminator on position).



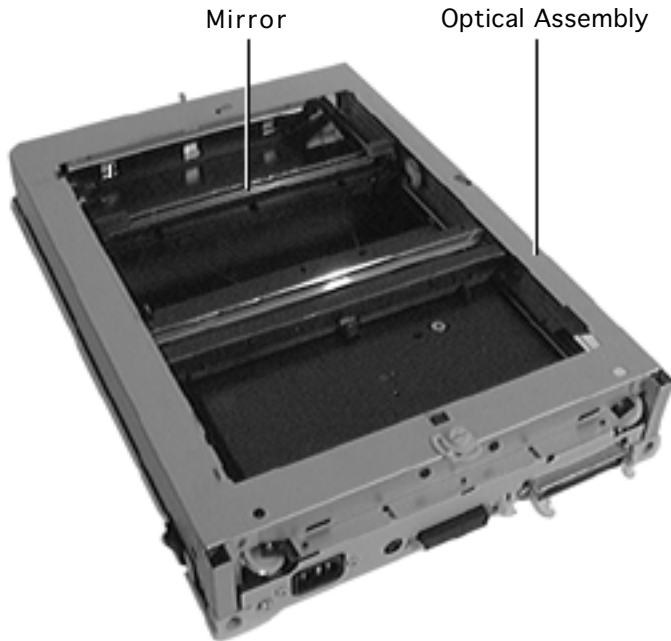

- 5 Set the SCSI ID switch back to 7, then back to 0 and finally back to 7.
- 6 The optical unit will now move. When the mirror has reached the position where it is between the set of four screws on the bottom, turn off the scanner.





Exploded View

Color OneScanner 600/27





Paper Separator, ADF
922-2047

Cover, Top w/Hinge
922-1930

Document Feeder,
Whole Unit
661-1119

Delivery Guide
Sheet, ADF
922-2048

Cover, Glass
922-1932

Cable Sensor
922-1937

Photo-
Interrupter
922-1353

Deflector, ADF
922-2049

Glass w/Scale
922-2024

Kit, Foot
076-0535

Holder, Glass
(pkg. of 10)
922-1933

Optical Assembly
661-1084

Gear, Motor (pkg. of 5)
922-2042

Bracket, Motor
(pkg. of 5)
922-2046

Inverter
Board
922-1936

Pad, Damper,
Motor
922-2045

Motor, Drive
922-1938

Plate, Shield
922-1934

Cable, LED
922-1935

Logic Board
661-1083

Power Supply
661-1085

