



Macintosh LC Series/ Quadra 605

Macintosh LC, Macintosh LC II,
Macintosh LC III, Macintosh LC 475,
Macintosh Quadra 605





Basics

Macintosh LC Series/Quadra 605





Overview

This manual includes complete repair procedures for the Macintosh LC Series/Quadra 605, shown at left.

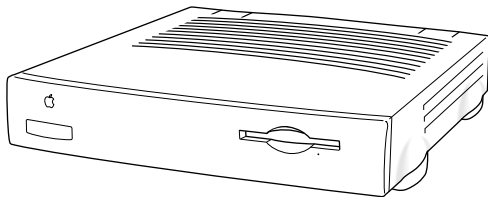

Figure: Macintosh LC Series, Quadra 605





Specifications

Macintosh LC Series/Quadra 605





Introduction

Specifications information for this product can be found in this chapter and also in the Spec Database, which you can access in one of three ways:

- Launch it directly by double-clicking the Apple Spec Database runtime alias at the top level of the Main Service Source CD.
- Select "Apple Spec Database" from the Service Source drop-down main menu.
- Click the Acrobat toolbar icon for the database, which is near the right end of the toolbar with the letters "SP."





Processor

LC	Motorola 68020 microprocessor 16 MHz 16-bit internal data bus
LC II	Motorola 68030 microprocessor 16 MHz 16-bit internal data bus Burst-mode RAM access
LC III	Motorola 68030 microprocessor 25 MHz 32-bit internal data bus Burst-mode RAM access Coprocessor socket





LC 475/Quadra 605

Motorola 68LC040 microprocessor

25 MHz

32-bit internal data bus

Burst-mode RAM access





Memory

DRAM

LC: 2 MB, expandable to 10 MB (100 ns or faster SIMMs)

LC II: 4 MB standard, expandable to 10 MB (100 ns or faster SIMMs)

LC III: 4 MB standard, expandable to 36 MB (80 ns or faster SIMMs)

LC 475/Quadra 605: 4 MB or 8 MB standard, expandable to 36 MB (80 ns or faster SIMMs)

ROM

LC/LC II: 512 K

LC III/LC 475/Quadra 605: 512K expandable to 1 MB





VRAM

LC: 256K VRAM, upgradable to 512K

LC II: 256K VRAM SIMM, upgradable to 512K

LCIII: 512K VRAM on board, upgradable to 768K

LC 475/Quadra 605: Two 256K VRAM SIMMs, upgradable to 1MB





Disk Storage

Floppy Drive

LC/ LC II/ LC III: Apple SuperDrive 1.4 MB Floppy Disk Drive

Optional second internal 1.4 MB floppy drive (LC only)

LC 475/Quadra 605: Apple SuperDrive 1.4 MB Floppy Disk Drive
or Apple SuperDrive Manual Insert Floppy Disk Drive

Hard Drive

LC: 40 MB or 80 MB

LC II: 40 MB, 80 or 160 MB

LC III: 40, 80 or 160 MB

LC 475/Quadra 605: 160 or 230 MB





I/O Interfaces

Serial	Two RS-232/RS-422 serial ports; mini DIN-8 connectors
SCSI	SCSI interface; DB-25 connector
Apple Desktop Bus	One ADB port; mini DIN-4 connector
Video	One DB-15 monitor port for built-in video; DA-15 connector
Sound	LC/LC II/LC III: Mono sound input and output port; mini phono plug LC 475/Quadra 605: Mono sound input port; stereo output; mini phono plug



**Expansion
Connector**

LC: 96-pin processor-direct slot (PDS) supporting 020 direct slot expansion card

LC II: 96-pin PDS supporting 020/030 direct slot expansion card

LC III: 114-pin PDS supporting 020/030 direct slot expansion card

LC 475/Quadra 605: 114-pin expansion slot supporting 030/040 expansion cards. Accepts Macintosh LC compatible I/O display, network, and video capture cards. Does not support 030 processor accelerator or cache cards.





I/O Devices

Keyboard

Apple Keyboard, Apple Keyboard II, Apple Extended Keyboard II, or Apple Adjustable Keyboard connected through ADB ports (mini DIN-4)

Mouse

ADB mouse and ADB Mouse II connected through ADB ports (mini DIN-4)

Microphone

Electret, omnidirectional
Operates on 8 VDC supplied by microphone port on CPU





Sound and Video

Sound

Monaural, 8-bit sound input at 11 or 22 kHz

LC, LC II, LC III: Monophonic, 8-bit sound generator supplying same signal to both channels of stereo equipment

LC 475 and Quadra 605: Stereo output capability

Video

LC and LC II provide built-in support for many monitors, including

- Apple High-Resolution Monochrome Monitor
- AppleColor High-Resolution RGB Monitor
- Macintosh 12-Inch RGB Display
- Macintosh 12-Inch Monochrome Display
- Macintosh Color Display
- Apple Basic Color Monitor



**Video (cont'd)**

LC III, LC 475 and Quadra 605 provide up to 16-bit support on 12-, 13-, and 16-inch monitors and 8-bit support on 15-inch portrait and 21-inch monitors. LC III, LC 475 and Quadra 605 support all Apple monitors available at CPU introduction dates, including

- Apple High-Resolution Monochrome Monitor
- AppleColor High-Resolution RGB Monitor
- Macintosh 12-Inch RGB Display
- Macintosh 12-Inch Monochrome Display
- Macintosh Color Display
- Apple Basic Color Monitor
- Macintosh 16-Inch Color Display (Macintosh LC III only)

LC III, LC 475 and Quadra 605 support NTSC and PAL.





Electrical

Line Voltage

100–240 VAC, automatically configured

Frequency

LC Series: 47–63 Hz

Quadra 605: 50–60 Hz

Maximum Power

LC/LC II: 50 W (not including monitor)

LC III: 30 W

Quadra 605: 26 W





Physical

Dimensions

Height: 3.0 in. (7.7 cm)

Width: 12.2 in. (31.0 cm)

Depth: 15.0 in. (38.2 cm)

Weight

8.8 lb. (4.0 kg)





Troubleshooting

Macintosh LC Series/Quadra 605





General

The Symptom Charts included in this chapter will help you diagnose specific symptoms related to your product. Because cures are listed on the charts in the order of most likely solution, try the first cure first. Verify whether or not the product continues to exhibit the symptom. If the symptom persists, try the next cure. (Note: If you have replaced a module, reinstall the original module before you proceed to the next cure.)

If you are not sure what the problem is, or if the Symptom Charts do not resolve the problem, refer to the Flowchart for the product family.

For additional assistance, contact Apple Technical Support.





Symptom Charts

Error Chords

Error chord sounds during startup (Macintosh LC)

- 1 Replace SIMMs.
- 2 Perform SIMM verification on replacement logic board.
- 3 Replace logic board. Retain customer's SIMMs.

Eight-tone error chord sounds during startup (LC II/III/475/Quadra 605)

- 1 Replace SIMMs.
- 2 Perform SIMM verification on replacement logic board.
- 3 Replace logic board. Retain customer's SIMMs.





Error Chords (Continued)

Four-tone error chord sounds during startup (Macintosh LC II)

- 1 Disconnect hard drive power cable and hard drive data cable and reboot system. If startup sequence is normal, run “Macintosh Hard Disk Test” and replace hard drive if necessary.
- 2 Disconnect floppy drive cable and reboot system. If startup sequence is normal, replace floppy drive.
- 3 Replace logic board. Retain customer’s SIMMs.





Built-in Video

Screen is dark, audio and at least one drive operate, fan runs, and LED is lit

- 1 Adjust brightness on monitor.
- 2 Try monitor with another Macintosh computer.
- 3 Check battery.
- 4 Replace monitor. Troubleshoot defective monitor. See Symptom Charts in appropriate monitor manual.
- 5 Replace video cable.
- 6 Replace VRAM SIMM.
- 7 Replace logic board. Retain customer's SIMMs.
- 8 Replace power supply.

Screen is dark, audio and drive do not operate, but fan runs and LED is lit

- 1 Remove expansion card, if present.
- 2 Remove peripherals.
- 3 Disconnect hard drive and floppy drive.
- 4 Replace SIMMs. Refer to Memory manual.
- 5 Replace logic board. Retain customer's SIMMs.
- 6 Replace power supply.





Built-in Video (Continued)

Partial or whole screen is bright and audio is present, but no video information is visible

- 1 Verify monitor works with another Macintosh.
- 2 Replace video cable.
- 3 Replace monitor.
- 4 Replace logic board. Retain customer's SIMMs.

Screen is completely dark, fan is not running, and LED is not lit

- 1 Plug monitor directly into wall socket. Verify that monitor has power.
- 2 Remove expansion card, if present.
- 3 Remove peripherals.
- 4 Disconnect hard drive and floppy drive.
- 5 Replace power supply.
- 6 Replace logic board. Retain customer's SIMMs.





Built-in Video (Continued)

Vertical lines, horizontal lines, or snow appears on screen, or screen is completely dark; startup tone is normal

- 1 Verify monitor works with another Macintosh.
- 2 Replace video cable.
- 3 Replace monitor.
- 4 Replace VRAM SIMM.
- 5 Replace logic board. Retain customer's SIMMs.
- 6 Replace power supply.





Floppy Drive

Audio and video are present, but internal drive does not operate

- 1 Replace floppy drive cable.
- 2 Replace floppy drive.
- 3 Replace logic board. Retain customer's SIMMs.

Disk ejects; display shows Mac icon with blinking "X"

- 1 Replace disk with known-good system disk.
- 2 Replace floppy drive cable.
- 3 Replace floppy drive.
- 4 Replace logic board. Retain customer's SIMMs.

Disk does not eject

- 1 Switch off system and hold mouse button down while switching system back on.
- 2 Remove top cover.
- 3 Eject disk manually by pushing opened paper clip into hole beside drive slot.
- 4 Replace floppy drive cable.
- 5 Replace floppy drive.





Floppy Drive (Continued)

Drive attempts to eject disk, but doesn't

- 1 Push disk completely in.
- 2 Eject disk manually by pushing opened paper clip into hole beside drive slot.
- 3 Check that cover is completely on.
- 4 Replace floppy drive.





Hard Drive

Internal hard drive runs continuously

- 1 Make sure System is version 6.0.7 (or later) for Macintosh LC, version 7.0.1 (or later) for Macintosh LC II, or version 7.1 (or later) for LC III/475 and Quadra 605.
- 2 Replace hard drive cable.
- 3 Replace internal hard drive.
- 4 Replace logic board. Retain customer's SIMMs.

Internal hard drive does not operate

- 1 Replace hard drive data cable.
- 2 Replace hard drive power cable.
- 3 Replace internal hard drive.
- 4 Replace logic board. Retain customer's SIMMs.





Peripherals

Works with internal or external SCSI device but does not work with both

- 1 Verify that SCSI select switch on external device is set to different priority from internal.
- 2 Verify that both ends of external SCSI device are terminated.
- 3 Replace terminator on external device.
- 4 Verify that terminator is installed on internal SCSI drive.
- 5 Replace SCSI select cable.

Cursor does not move

- 1 Reboot system.
- 2 Check mouse connection.
- 3 If mouse was connected to keyboard, connect mouse to rear ADB port and disconnect keyboard. If mouse works, replace keyboard.
- 4 If mouse does not work in any ADB port, replace mouse.
- 5 Remove additional PDS cards.
- 6 Reset PRAM.
- 7 Replace logic board. Retain customer's SIMMs.





Peripherals (Continued)

Cursor moves, but clicking mouse button has no effect

- 1 Replace mouse.
- 2 Replace logic board. Retain customer's SIMMs.

Double-click doesn't open application, disk, or server

- 1 Remove extra system files on hard drive.
- 2 Clear parameter RAM. System 7: Hold down <Command> <Option> <P> <R> during startup but before "Welcome to Macintosh" appears. System 6 and earlier: Hold down <Command> <Option> <Shift> keys and select Control Panel from Apple menu.
- 3 If mouse was connected to keyboard, connect mouse to rear ADB port and disconnect keyboard. If mouse works, replace keyboard.
- 4 If mouse does not work in any ADB port, replace mouse.
- 5 Replace logic board. Retain customer's SIMMs.





Peripherals (Continued)

No response to any key on keyboard

- 1 Make sure System is version 6.0.7 (or later) for Macintosh LC, version 7.0.1 (or later) for Macintosh LC II, or version 7.1 (or later) for LC III/475 and Quadra 605.
- 2 Check keyboard connection to ADB port.
- 3 Replace keyboard cable.
- 4 Replace keyboard.
- 5 Remove battery for 15 to 30 minutes to reset logic board.
- 6 Replace logic board. Retain customer's SIMMs.





Peripherals (Continued)

Known-good
LaserWriter does not
print

- 1 Make sure that Chooser and Control Panel settings are correct.
- 2 Make sure System is version 6.0.7 (or later) for Macintosh LC, version 7.0.1 (or later) for Macintosh LC II, or version 7.1 (or later) for LC III/475 and Quadra 605.
- 3 Reset PRAM.

Known-good
ImageWriter or
ImageWriter II does
not print

- 1 Make sure that Chooser and Control Panel settings are correct.
- 2 Make sure System is version 6.0.7 (or later) for Macintosh LC, version 7.0.1 (or later) for Macintosh LC II, or version 7.1 (or later) for LC III/475 and Quadra 605.
- 3 Check printer DIP switches.
- 4 Reset PRAM.
- 5 Replace printer interface cable.
- 6 Replace logic board. Retain customer's SIMMs.





Miscellaneous

- | | | |
|--|---|---|
| Clicking, chirping,
or thumping | 1 | Disconnect hard drive. Replace drive if noise disappears. |
| | 2 | Replace power supply. |
| | 3 | Replace logic board. Retain customer's SIMMs. |
| System shuts down or
restarts
intermittently | 1 | Make sure air vents on back and top of case are unobstructed. Thermal protection circuitry may shut down computer. After 30 to 40 minutes, system should be OK. |
| | 2 | Replace power cable. |
| | 3 | Install standoffs on LC Ethernet Card, if present. |
| | 4 | Replace power supply. |
| | 5 | Replace SIMMs. Refer to Memory manual. |
| | 6 | Replace logic board. Retain customer's SIMMs. |





Miscellaneous (Continued)

System
intermittently
crashes or locks up

- 1 Make sure System is version 6.0.7 (or later) for Macintosh LC, version 7.0.1 (or later) for Macintosh LC II, or version 7.1 (or later) for LC III/475 and Quadra 605.
- 2 Make sure software is known-good.
- 3 Replace logic board. Retain customer's SIMMs.
- 4 Replace SIMMs.
- 5 Replace power supply.

No sound from
speaker

- 1 Verify that volume setting in Control Panel is 1 or above.
- 2 Reset PRAM.
- 3 Verify nothing is connected to sound-out port.
- 4 Replace speaker.
- 5 Replace logic board. Retain customer's SIMMs.





Miscellaneous (Continued)

System seems to boot, then message “Finder is old version” displays

- 1 Clear parameter RAM. System 7: Hold down <Command> <Option> <P> <R> during startup but before “Welcome to Macintosh” appears. System 6 and earlier: Hold down <Command> <Option> <Shift> keys and select Control Panel from Apple menu.
- 2 Replace logic board. Retain customer’s SIMMs.

System intermittently doesn’t power on

- 1 Check cables.
- 2 Plug monitor directly into wall socket. Verify that monitor has power.
- 3 Try known-good keyboard and ADB cable.
- 4 Replace power cord.
- 5 Check batteries. See “Battery Verification” in Additional Procedures.
- 6 Replace logic board. Retain customer’s SIMMs.





Miscellaneous (Continued)

Monitor raster width too narrow	Refer to Adjustments section in the appropriate monitor manual for horizontal size (width) adjustment.
Stand-alone system hangs or crashes	<ol style="list-style-type: none">1 If using an older LC Ethernet card with a computer running System 7, disable virtual memory.2 Clear parameter RAM. System 7: Hold down <Command> <Option> <P> <R> during startup but before “Welcome to Macintosh” appears. System 6 and earlier: Hold down <Command> <Option> <Shift> keys and select Control Panel from Apple menu.3 Upgrade to latest revision of software.4 Remove additional RAM and PDS card.5 Replace logic board





Miscellaneous (Continued)

Networked 33 MHz LC III freezes	<ol style="list-style-type: none">1 Verify 10Base-T cable is secure.2 Replace 10Base-T adapter card.3 Remove additional RAM and external SCSI devices.4 Replace logic board.
Clock doesn't run	<ol style="list-style-type: none">1 Replace battery. See "Battery Replacement" in Additional Procedures.2 Reset PRAM.3 Verify nothing is connected to sound-out port.4 Replace logic board. Retain customer's SIMMs.
System doesn't recognize more than 10 MB of RAM (LC/LC II)	Although you can install up to 12 MB of RAM in Macintosh LC/LC II computers, 10 MB is the maximum amount of RAM that the system recognizes.





Take Apart

Macintosh LC Series/Quadra 605



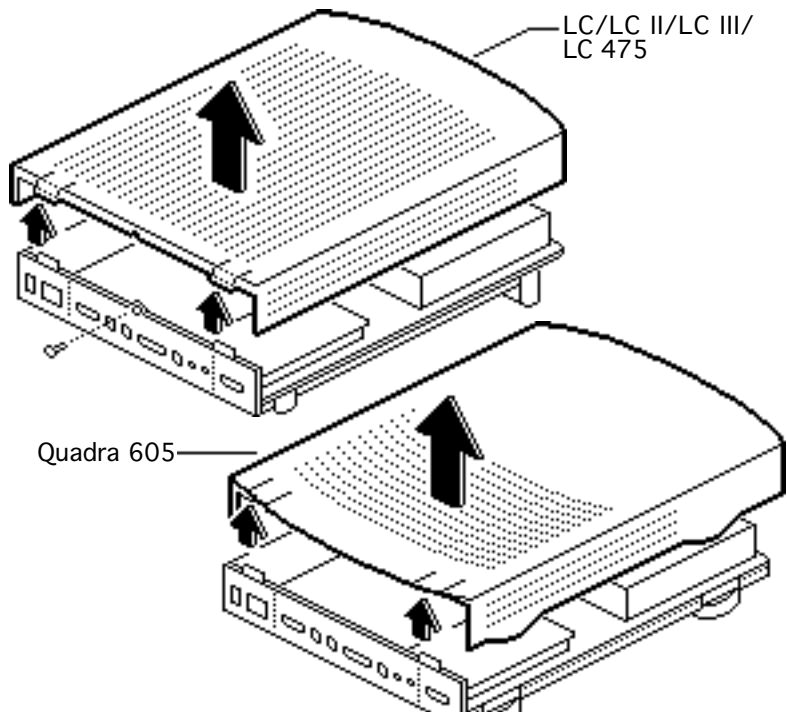

Top Cover

No preliminary steps are required before you begin this procedure.

- 1 Remove the case screw if one is present.
- 2 Lift the tabs at the back of the lid.
- 3 Lift the top cover straight up.





Hard Drive

Before you begin, remove the top cover.

Caution: Review the ESD precautions in Bulletins/ Safety.

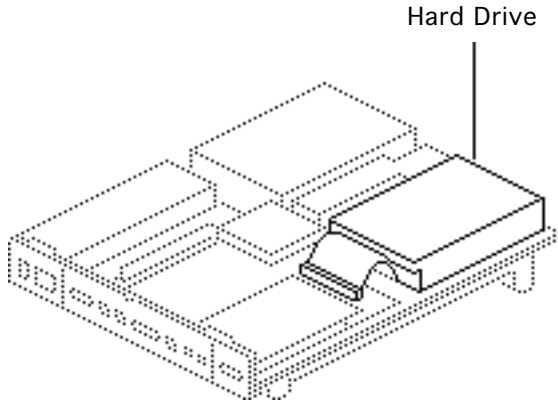

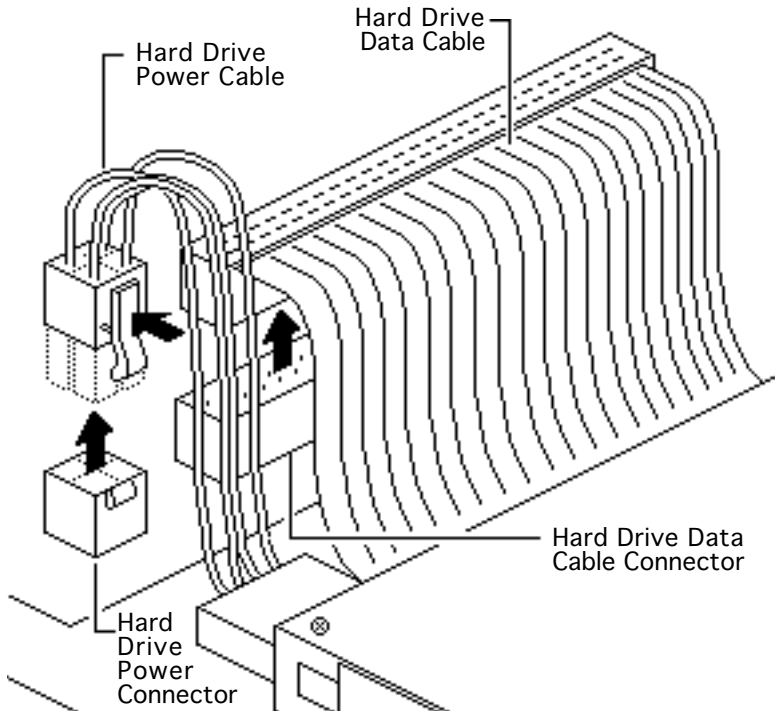

- 1 Release the locking tab and disconnect the hard drive power cable from the connector on the logic board.
- 2 Disconnect the hard drive data cable from the connector on the logic board.



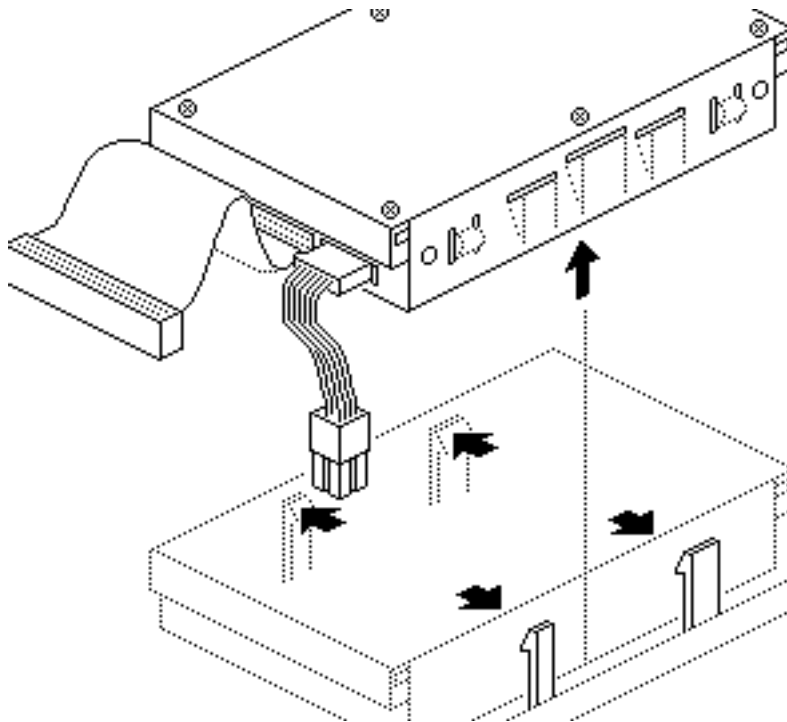

- 3 Release the two plastic latches on one side of the hard drive and lift the drive slightly. Repeat on the other side of the drive and remove the drive (with carrier) from the computer.

Replacement Note: For information on removing the hard drive from the carrier and returning drives, cables, and carriers to Apple, refer to “Additional Procedures” in the Hard Drives manual.





Fan/Speaker Assembly (LC)

Before you begin, remove the top cover.

Caution: Review the ESD precautions in Bulletins/Safety.

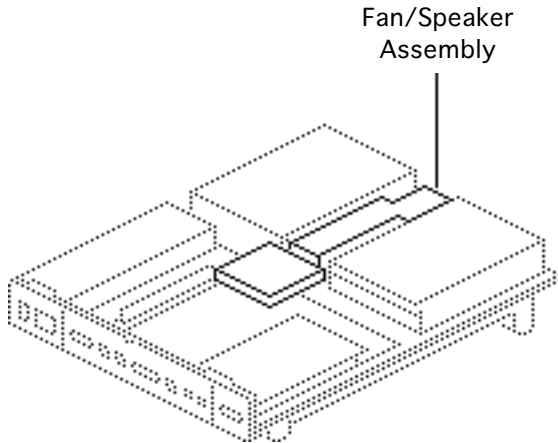

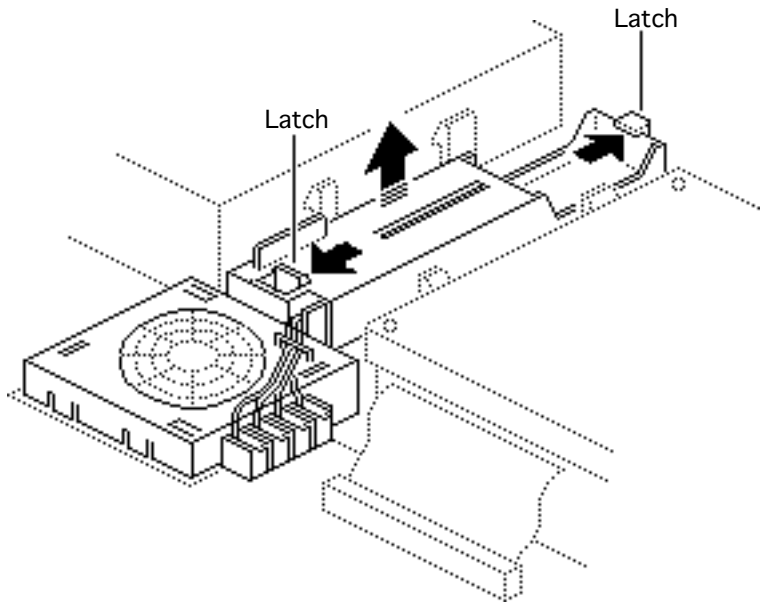

- 1 Release the latch on one end of the fan/speaker assembly, and lift the assembly slightly.
- 2 Release the other latch and remove the fan/speaker assembly from the bottom case.





Fan (LC II/III)

Before you begin, remove the top cover.

Caution: Review the ESD precautions in Bulletins/ Safety.

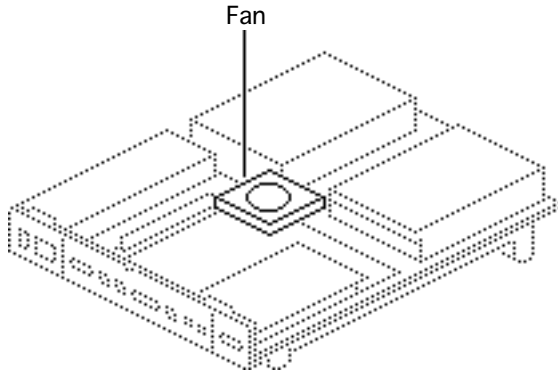

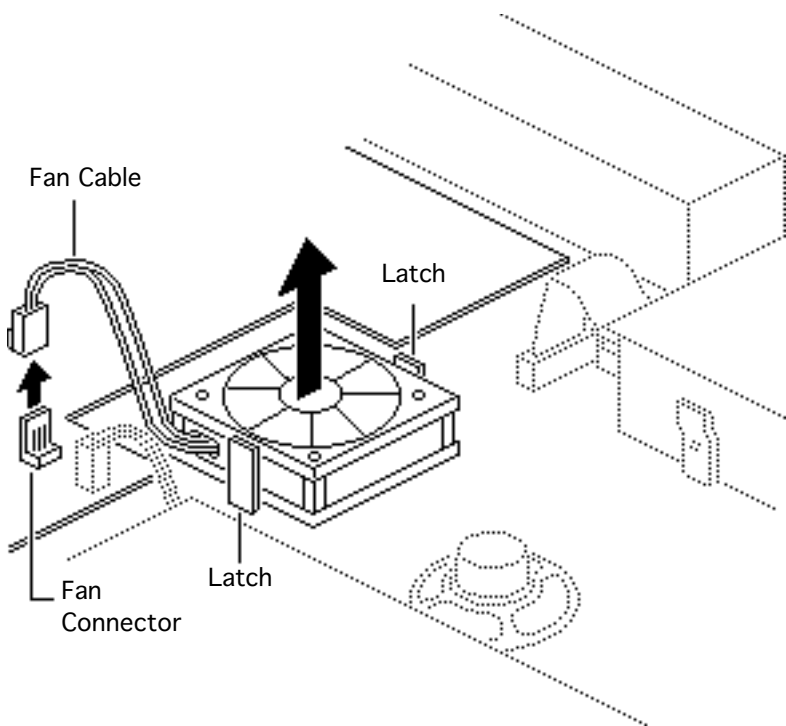

- 1 Disconnect the fan cable from the fan connector on the logic board.
- 2 Release the plastic latches and lift the fan from the case.

Replacement Caution: Be sure to install the fan with the logo side down, or the fan may damage the computer.





Speaker (LCII/III)

Before you begin, remove the following:

- Top cover
- Hard drive

Caution: Review the ESD precautions in Bulletins/Safety.

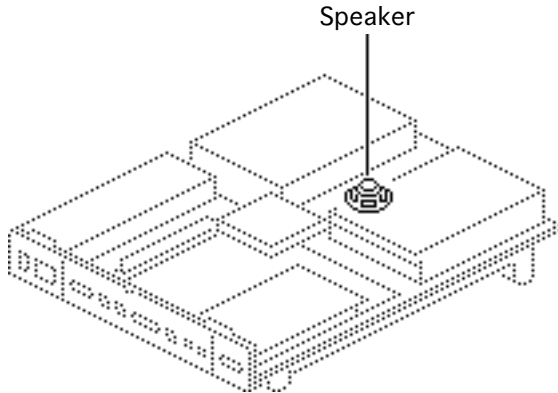

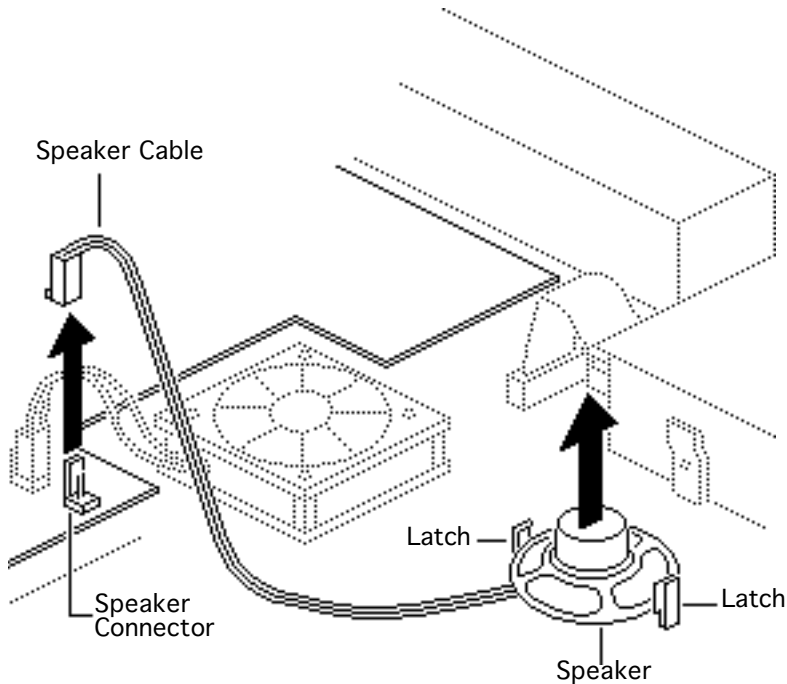

- 1 Disconnect the speaker cable from the speaker connector on the logic board.
- 2 Release the plastic latches and lift the speaker from the case.

Replacement Note: Before reconnecting the speaker cable, thread it through the top two brackets that hold the hard drive in place.





Floppy Drive

Before you begin, remove the top cover.

Caution: Review the ESD precautions in Bulletins/ Safety.

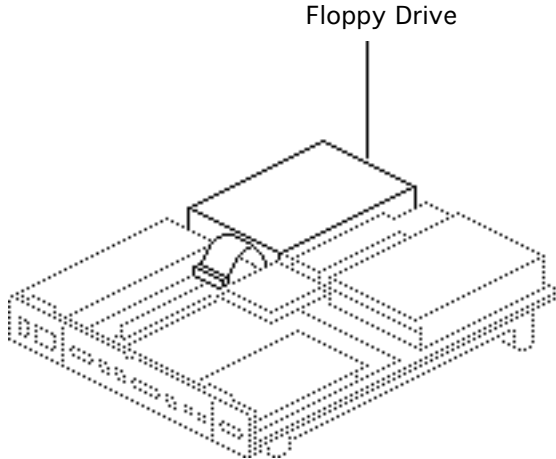

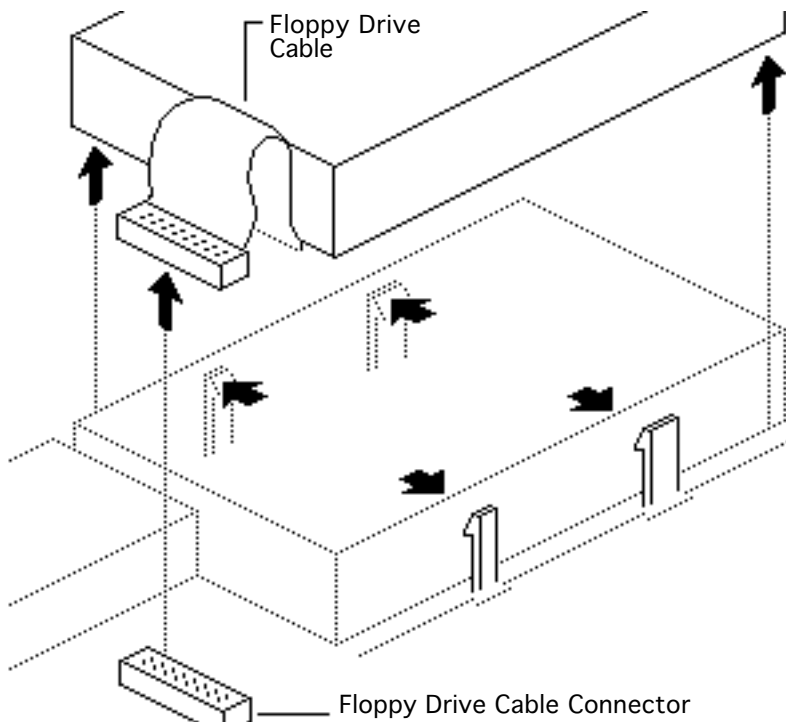

Macintosh LC

- 1 Disconnect the floppy drive cable from the connector on the logic board.

Note: Retain the old floppy drive cable. Use the old cable on the new exchange module.

- 2 Release the two latches on one side of the drive and lift the drive slightly. Repeat on the other side and remove the drive from the case.





Replacement Note: Before you install a replacement 1.4 MB SuperDrive, you must remove the dust shield.



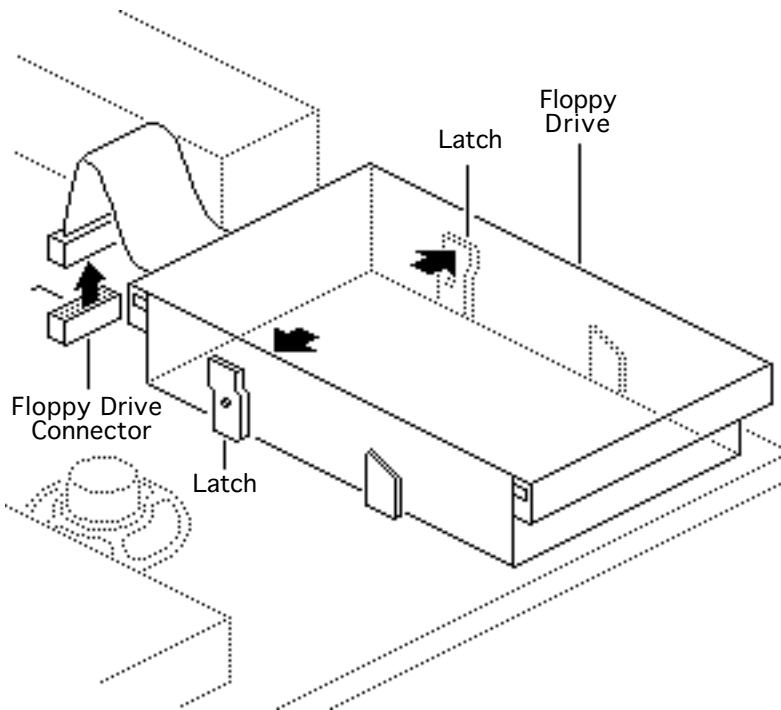

LC II/LC III/Quadra 605

- 1 Disconnect the floppy drive cable from the connector on the logic board.
- 2 Release the two latches at the rear of the floppy drive and remove the drive from the case.

Replacement Note: Before you install a replacement auto-inject 1.4 MB SuperDrive, you must remove the dust shield, if present.





Replacement Note: You may encounter either an Apple SuperDrive or a manual eject floppy drive in some models. Replace floppy drives like for like.





Power Supply

Before you begin, remove the top cover.

Caution: Review the ESD precautions in Bulletins/Safety.

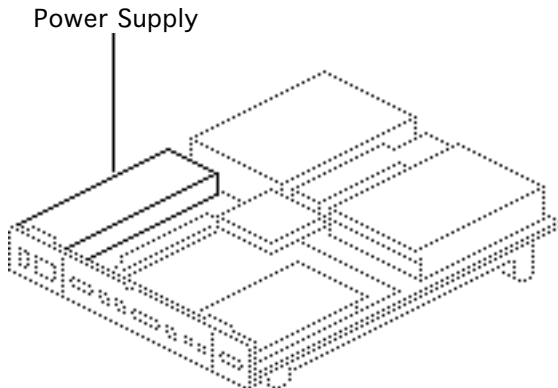

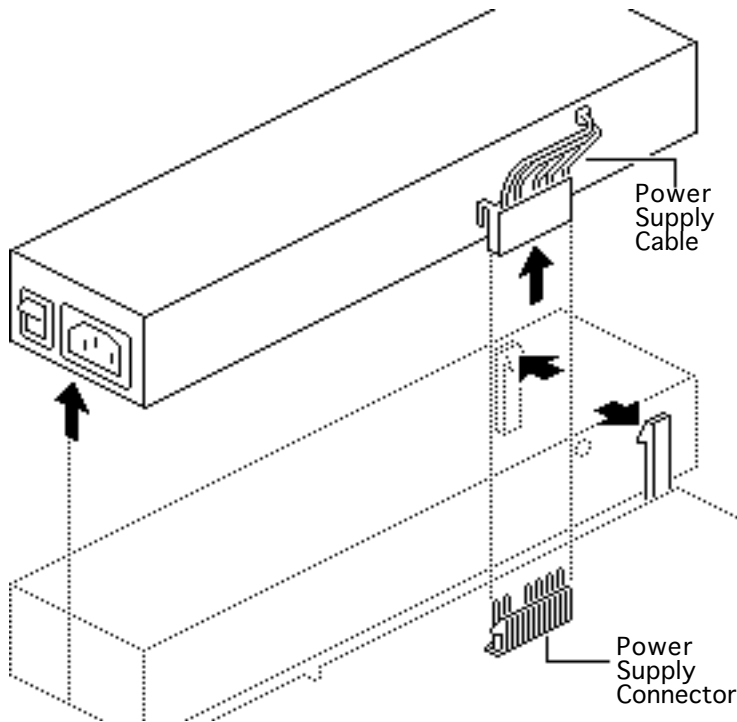

- 1 Disconnect the power supply cable from the connector on the logic board.
- 2 Release the two latches that secure the front end of the power supply to the bottom case, and lift the power supply out of the case.





Logic Board

Before you begin, remove the following:

- Top cover
- Fan/speaker assembly (LC)
- Fan (LC II/III/475 and Quadra 605)

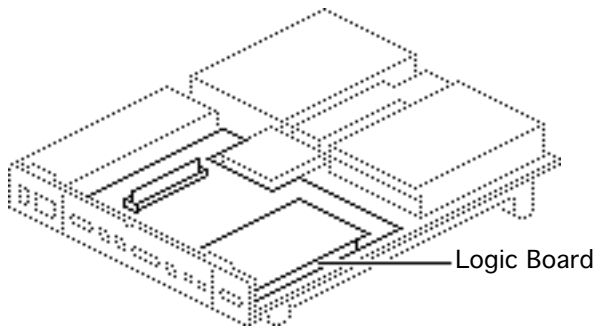

Caution: Review the ESD precautions in Bulletins/Safety.



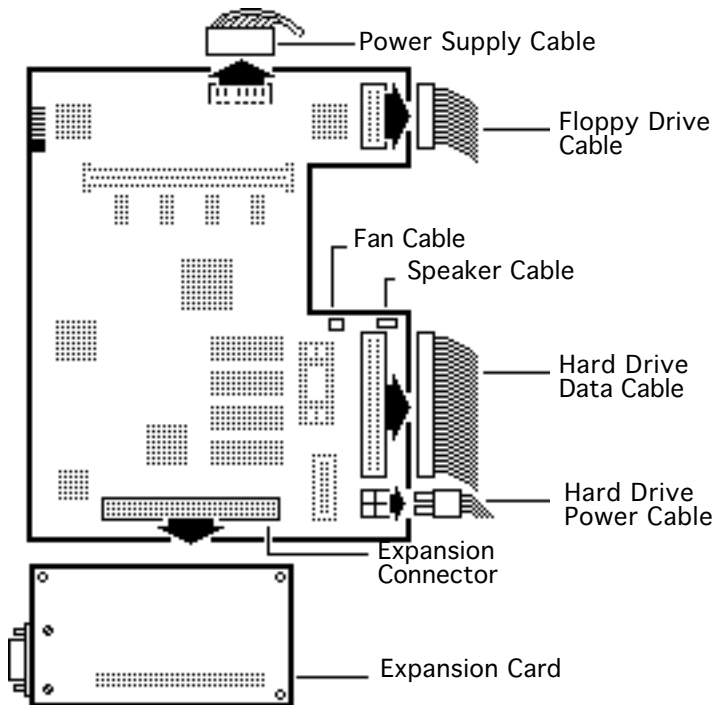

- 1 Disconnect the following cable connectors from the logic board:
 - Hard drive power cable
 - Hard drive data cable
 - Floppy drive cable
 - Power supply cable
 - Fan cable (LC II/III/LC 475 and Quadra 605)
 - Speaker cable (LC II/III/LC 475 and Quadra 605)
- 2 Remove the expansion card (if installed).





Caution: In the next step, be sure the power on/off button clears the rear panel before you remove the logic board. While lifting the board, do not touch any components or connectors on the back of the logic board. (The oil from your skin can harm the connectors.)





- 3 Using your forefingers, spread the two latches that secure the logic board to the bottom case. At the same time, using your right thumb, push on the expansion connector and slide the logic board toward the front of the case.

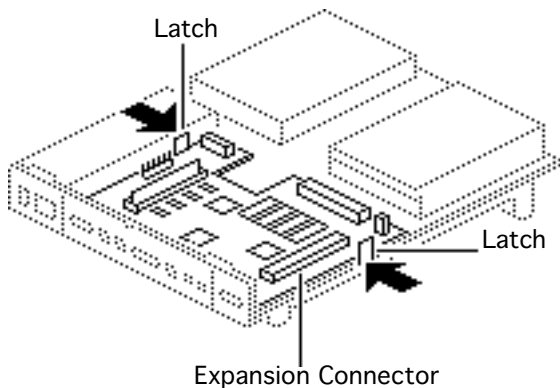



- 4 Gently lift the board from the case.

Replacement Note: Remove the SIMMs from the defective logic board and install them on the replacement logic board.

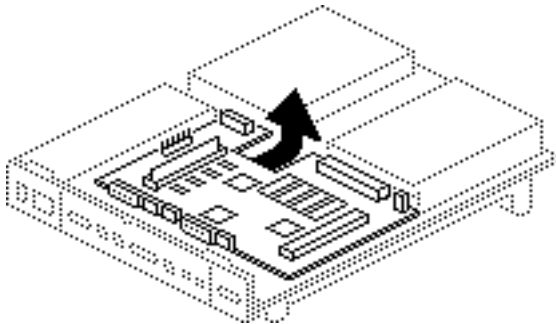



Quadra 605 Logic Board

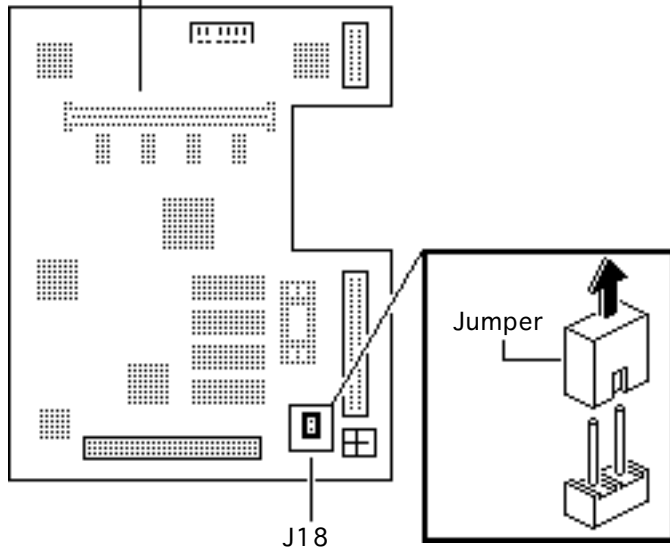

- 5 Remove the jumper from the pins at location J18 on the defective board.

Replacement Note: The LC 475 and Quadra 605 use the same logic board replacement. The Quadra 605 requires a jumper to connect the pins at location J18. Quadra 605 service replacement logic boards do not include the jumper.





Quadra 605 Logic Board

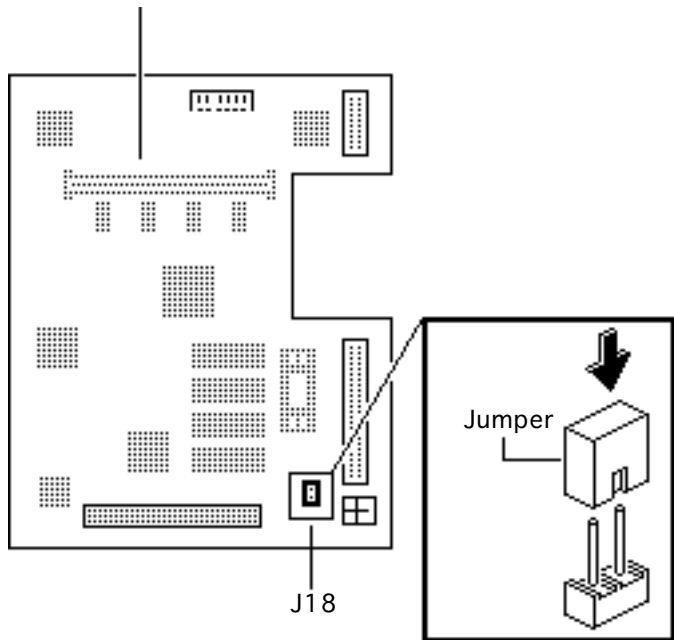

- 6 Install a jumper on the pins at location J18 on the Quadra 605 service replacement logic board.



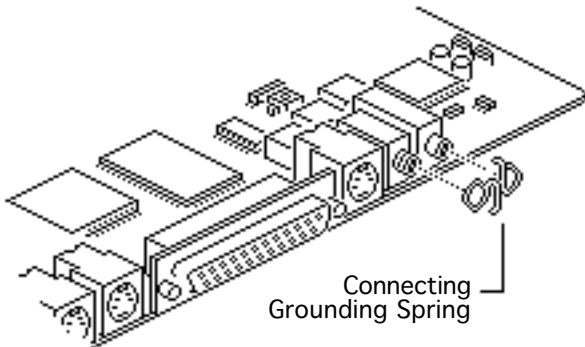
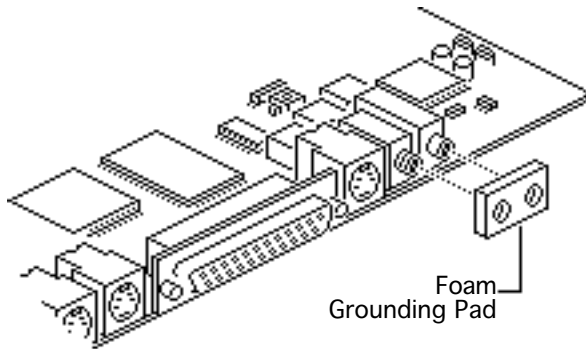

Replacement Note: The replacement logic boards for the LC 475 and the Quadra 605 do not include grounding connectors. You must remove the grounding connector from the defective board and install it on the replacement board.

There are two versions of grounding connectors, a foam grounding pad and a connecting grounding spring. You may encounter either version on LC 475 and Quadra 605 logic boards.



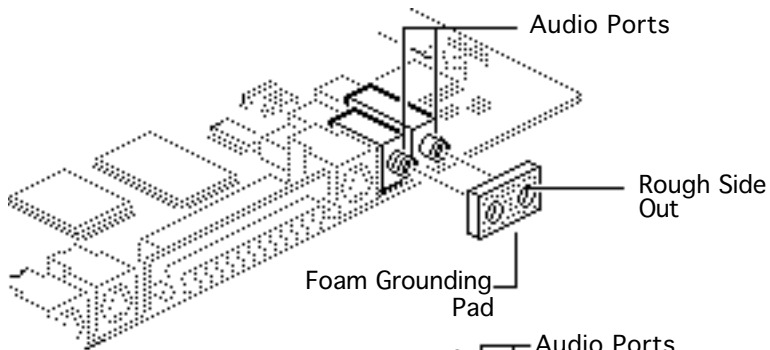

- 7 Install the foam grounding pad on the audio ports of the replacement logic board with the rough side of the pad facing out.

- 8 Install the connecting grounding spring on the audio ports of the replacement logic board with the arms of the spring facing out.

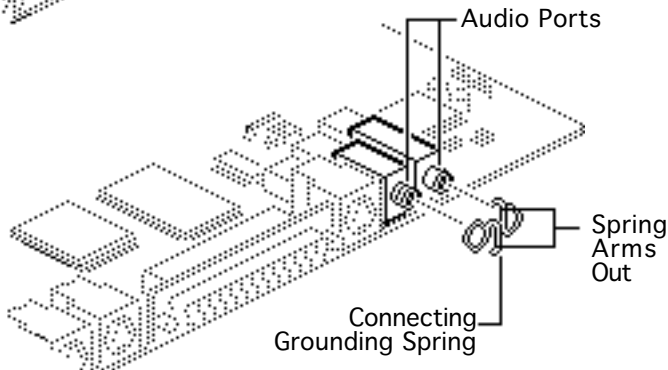



Upgrades

Macintosh LC Series/Quadra 605





LC Ethernet Upgrade

Before you begin, remove the top cover.

Caution: Review the ESD precautions in Bulletins/ Safety.

Note: The finished goods LC Ethernet Card package includes the LC Ethernet Card and standoffs. If you order service parts, you must order the standoffs separately from the card.

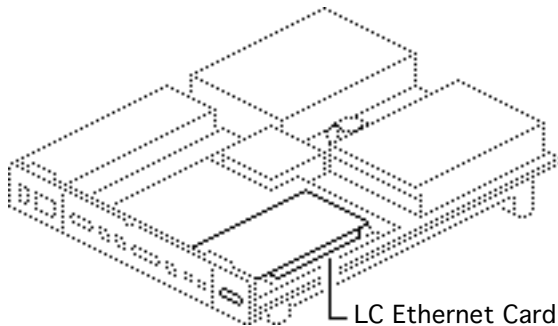

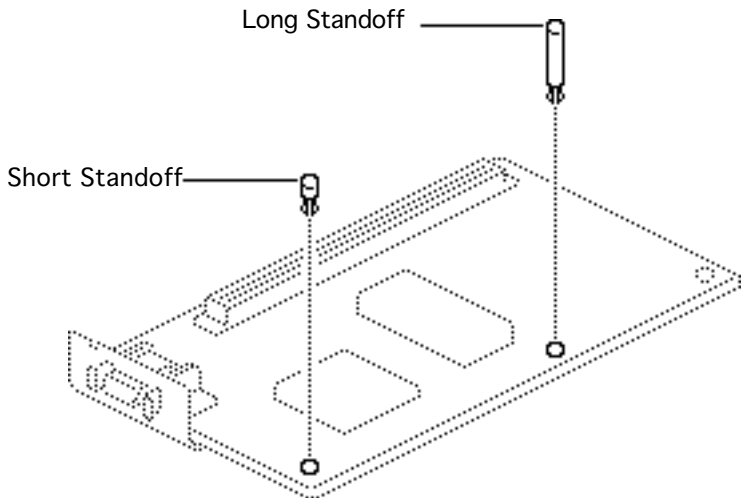

- 1 Insert the short standoff in the hole on the corner near the connector end of the card.
- 2 Insert the long standoff in the hole on the center edge of the card.

Caution: Failure to install the standoffs can cause the computer to restart intermittently.



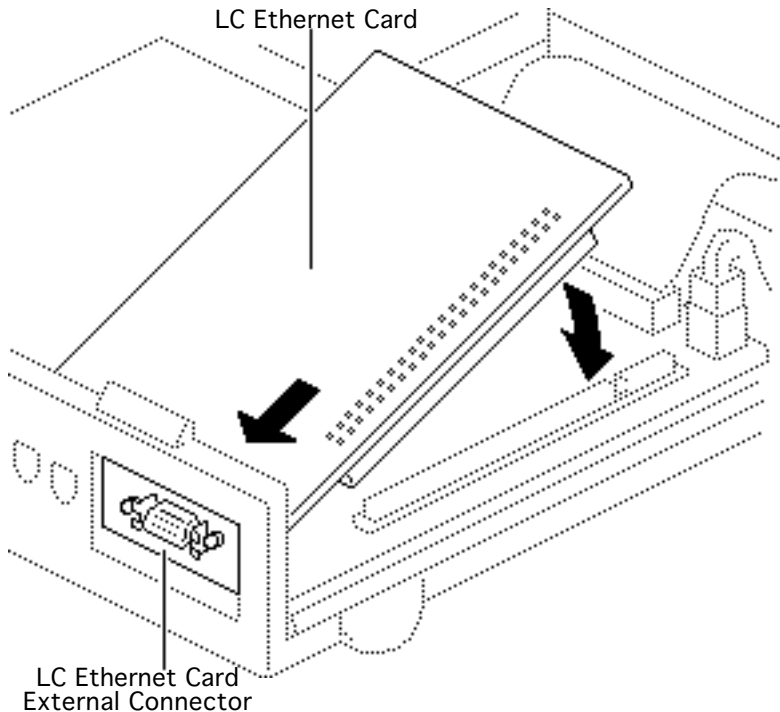

- 3 Position the card so that the external connector extends through the expansion connector opening.
- 4 Pivot the card over the expansion slot.
- 5 Press the connector pins into the connector slot.

Note: Do not force the card into the slot. If you meet a lot of resistance, pull the card out and reset it.





LC II Upgrade

Before you begin, remove the following:

- Top cover
- Fan/speaker assembly
- Logic board

Caution: Review the ESD precautions in Bulletins/ Safety.

Note: A Macintosh LC II upgrade kit upgrades a Macintosh LC to a Macintosh LC II. The upgrade kit includes a Macintosh LC II logic board and cover.

Macintosh LC Logic Board

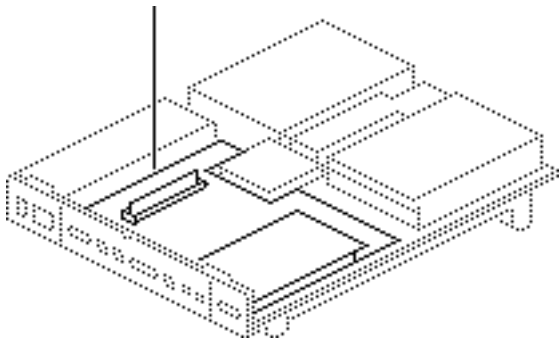



Macintosh LC II Logic Board

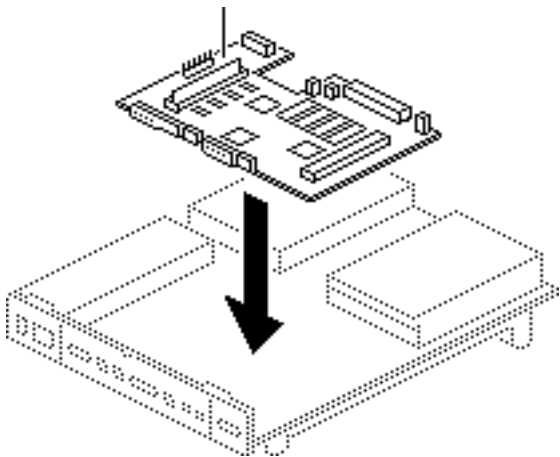

- 1 Install the Macintosh LC II logic board.
- 2 Install the customer's SIMMs into the new logic board.



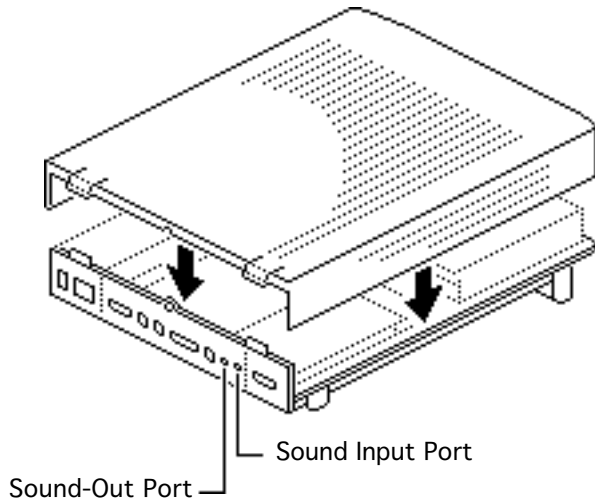

Replacement Note: After replacing the fan/speaker assembly, install the Macintosh LC II top cover.

Make sure that the connections to the sound-out and sound input ports are correct. Inserting equipment into the wrong port can damage the computer or equipment.





LC to LC III Upgrade

Macintosh LC III Upgrade

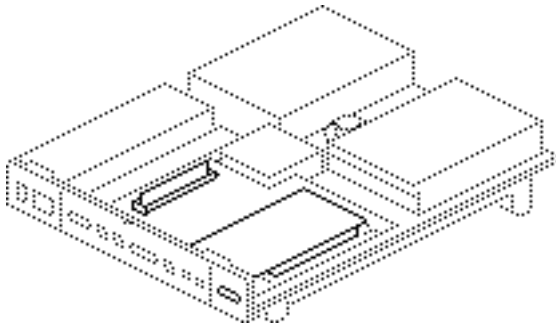

Before you begin, remove the following:

- Top cover
- Fan/speaker assembly
- Floppy drive
- Logic board

Caution: Review the ESD precautions in Bulletins/Safety.





Note: A Macintosh LC III upgrade kit includes LC III logic board, bottom case, top cover, power supply, speaker, fan, and floppy drive carrier.

Note: You will use only a few parts from the original LC in upgrading an LC to an LC III. The following procedures explain how to remove the LC parts and install them into the LC III upgrade unit.



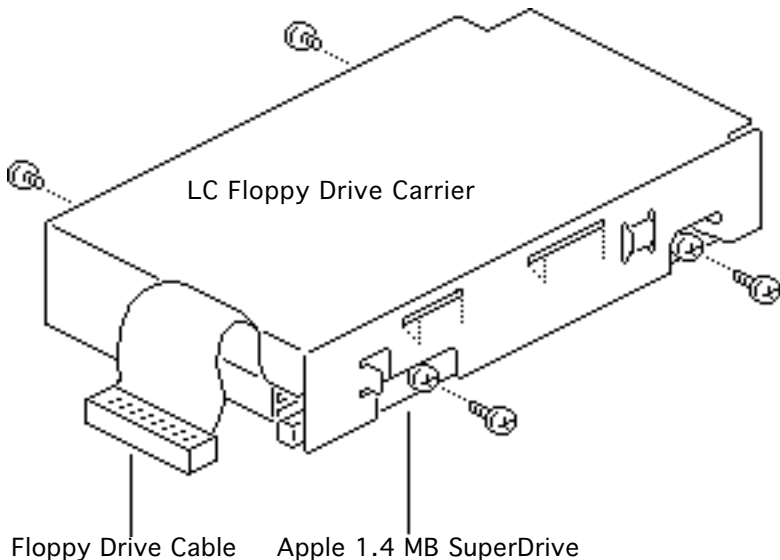

- 1 Remove the Macintosh LC floppy drive and floppy drive cable. (See “Floppy Drive” in Take Apart.)
- 2 Remove the floppy drive and cable from the LC floppy drive carrier.





- 3 Install the floppy drive with cable into the LC III floppy drive carrier.

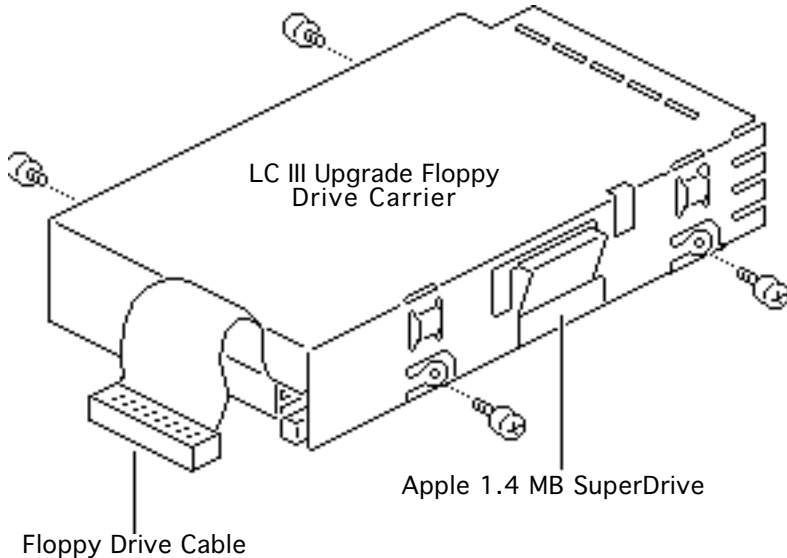

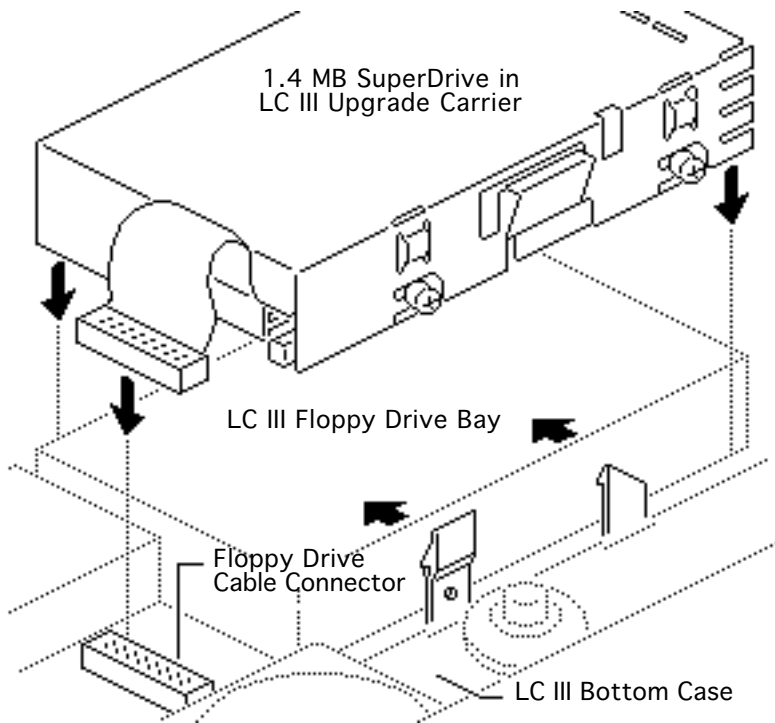

- 4 Install the floppy drive into the floppy drive bay of the LC III upgrade bottom case.
- 5 Connect the floppy drive cable to the floppy drive connector on the logic board.

Replacement Note: If you are installing a replacement auto-inject 1.4 MB SuperDrive, you must remove the dust shield, if present.



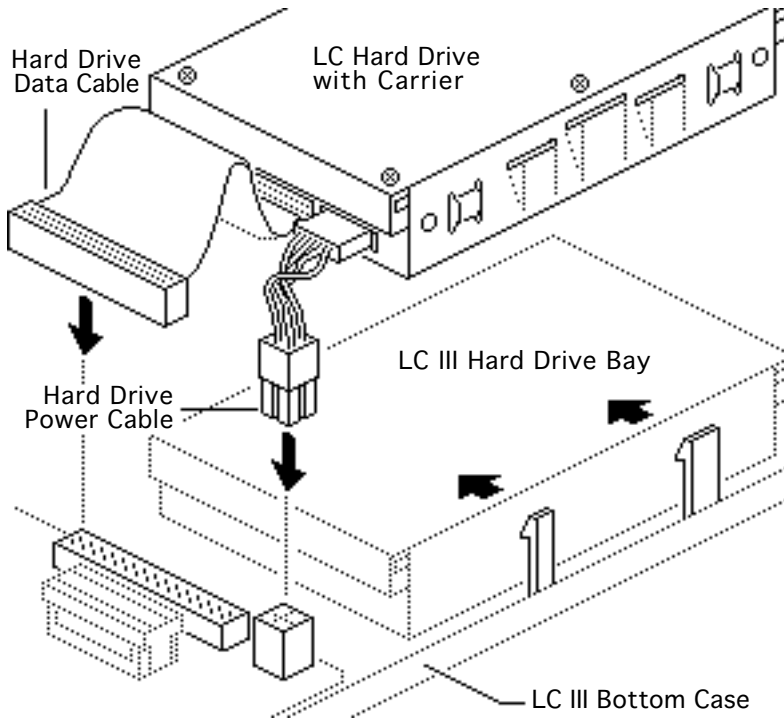

- 6 Remove the Macintosh LC hard drive with carrier, hard drive data cable, and hard drive power cable. (See “Hard Drive” in Take Apart.)
- 7 Install the LC hard drive into the hard drive bay of the LC III upgrade bottom case.
- 8 Connect the hard drive data cable and hard drive power cable connectors to the connectors on the LC III upgrade logic board.



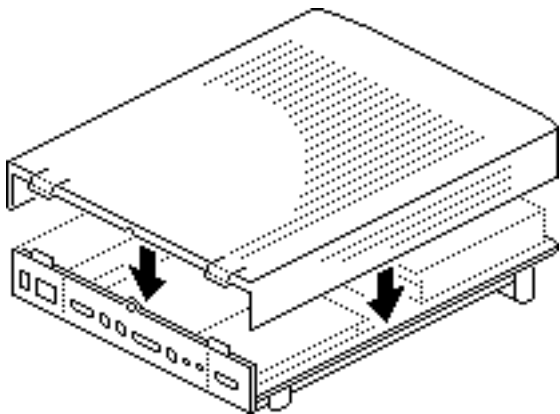

- 9 Install the LC VRAM SIMMs and the expansion card (if present) into the LC III upgrade logic board.

Note: DRAM SIMMs from an LC are not compatible with the LC III.

- 10 Attach the top cover.





LC II to LC III Upgrade

Before you begin, remove the top cover.

Caution: Review the ESD precautions in Bulletins/Safety.

Macintosh LC III Upgrade

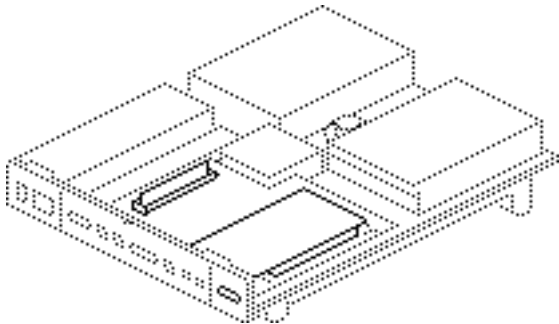



Note: A Macintosh LC III upgrade kit upgrades a Macintosh LC II to a Macintosh LC III. The upgrade kit includes a Macintosh LC III logic board, top cover, fan, speaker, and a floppy drive carrier. When upgrading an LC II to an LC III, you will need only the LC III logic board.





- 1 Install the Macintosh LC III logic board. (See Take Apart chapter.)

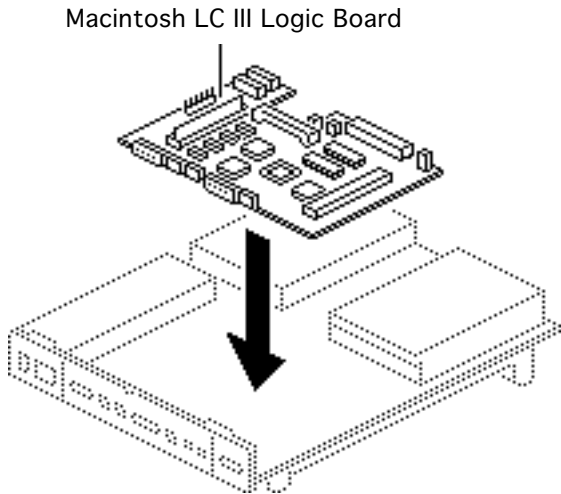



- 2 Install the fan and new Macintosh LC III top cover (see Take Apart chapter).

Replacement Caution: Make sure that the connections to the sound-out and sound input ports are correct. Inserting equipment into the wrong port can damage the computer or equipment.

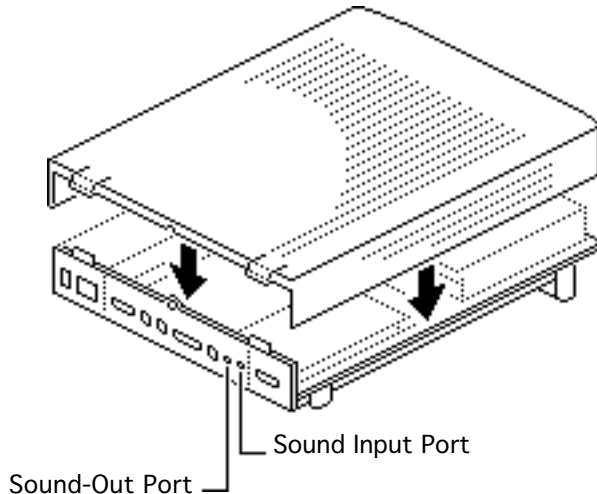



LC 475 Logic Board Upgrade

Before you begin, remove the following:

- Top cover
- Fan
- Logic board

Caution: Review the ESD precautions in Bulletins/Safety.

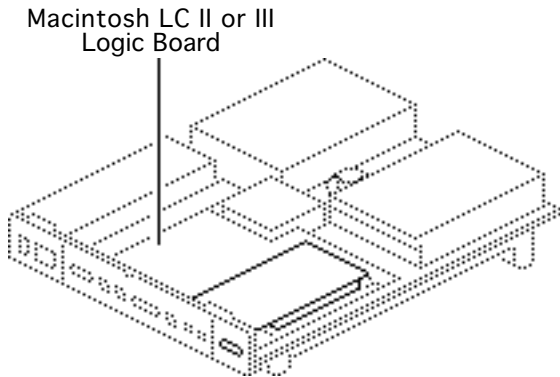



Note: A Macintosh LC 475 upgrade kit upgrades a Macintosh LC II or III to a Macintosh LC 475. The upgrade kit includes a Macintosh LC 475 logic board and product ID labels.



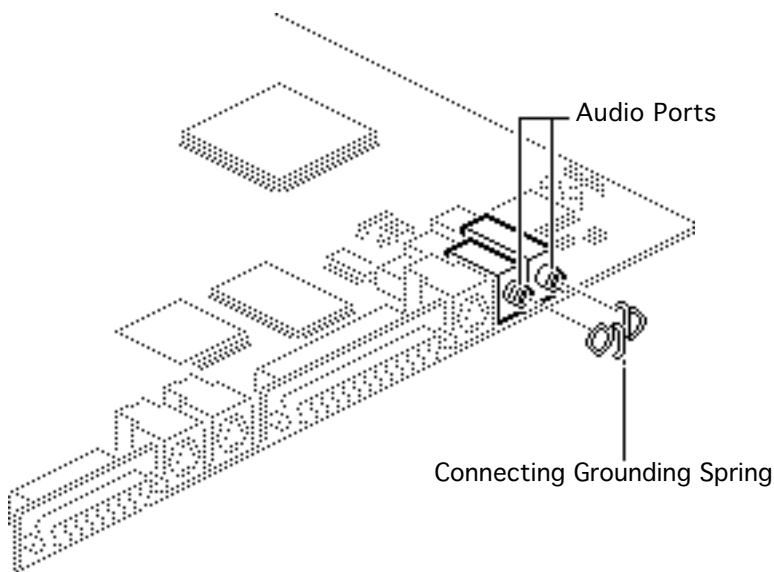

- 1 **Note:** The upgrade kit does not include a connecting grounding spring. You must order this part separately.

Before installing the upgrade logic board, install the connecting grounding spring on the audio ports of the board, with the arms of the spring facing out.





- 2 Install the Macintosh LC 475 logic board.

Macintosh LC 475 Logic Board

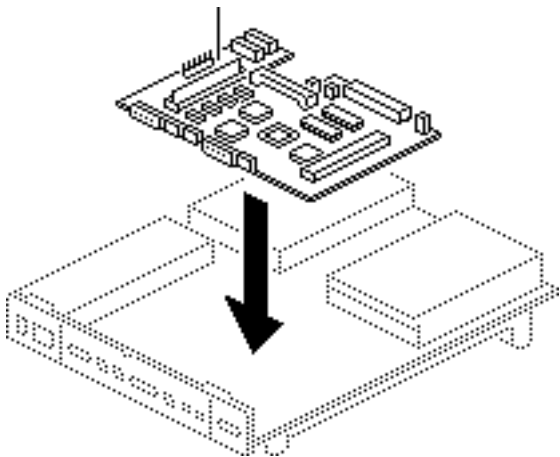



- 3 Install the fan and top cover (see Take Apart chapter).

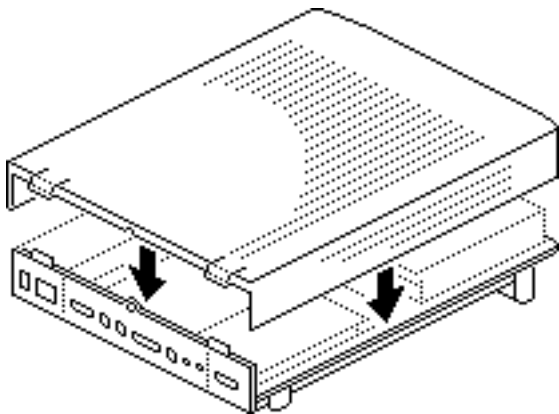



Macintosh Processor Upgrade

Before you begin, remove the following:

- Top cover
- I/O door
- Logic board
- Card in the PDS slot (if any)

Caution: Review the ESD precautions in Bulletins/ Safety.

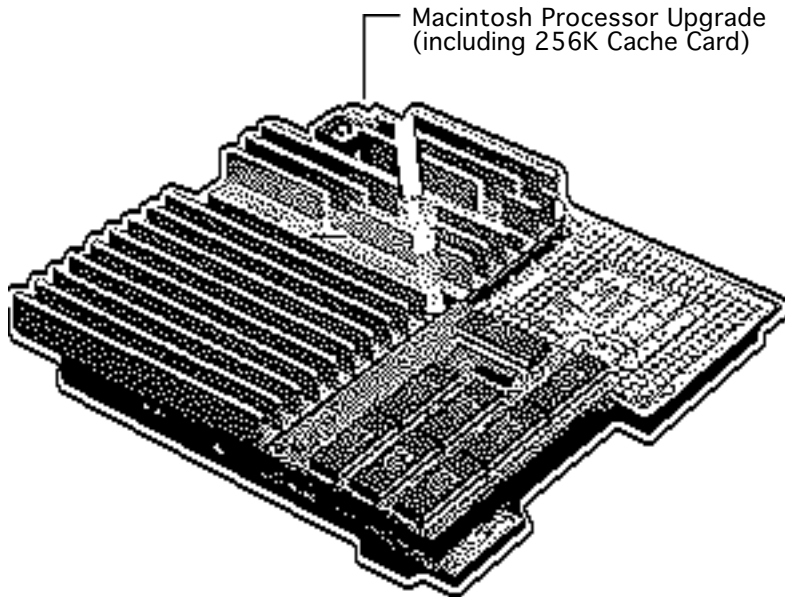

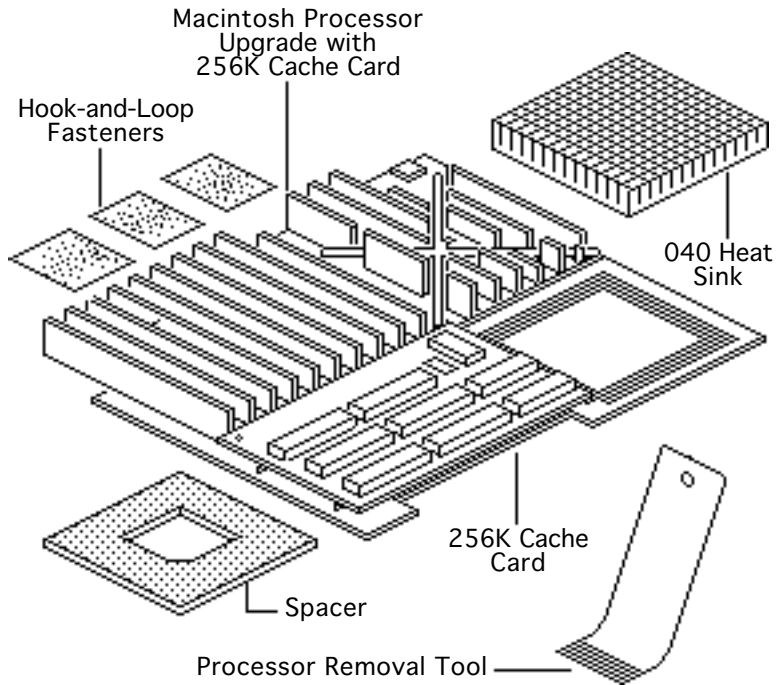

Note: The Macintosh Processor Upgrade kit allows 68LC040 computers to switch between a PowerPC 601 processor and a 68LC040 processor. The upgrade board includes the PowerPC 601 processor on board and a socket to accept the customer's 68LC040 processor.

Note: Refer to the Macintosh Processor Upgrade manual under the Power Macintosh menu for information about specifications and troubleshooting.





Note: The Macintosh Processor Upgrade comes packaged with the Macintosh Processor Upgrade board, 256K cache card, 040 heat sink, and hook-and-loop fasteners. If you need to order service replacement parts, order the parts separately.

Note: To install the upgrade, you will need a processor removal tool. Order the removal tool as a separate service part.





Note: The cache card comes installed on the upgrade board.





Installation Procedure Overview

There are three basic steps to installing the Macintosh Processor Upgrade on LC 475 and Quadra 605 computers.

- Remove the 68LC040 processor from the customer's logic board
- Install the 68LC040 processor on the upgrade board
- Install the upgrade board on the logic board

Detailed procedures follow.





- 1 Locate the 68LC040 processor on the logic board.
- 2 Remove the 68LC040 processor from the logic board

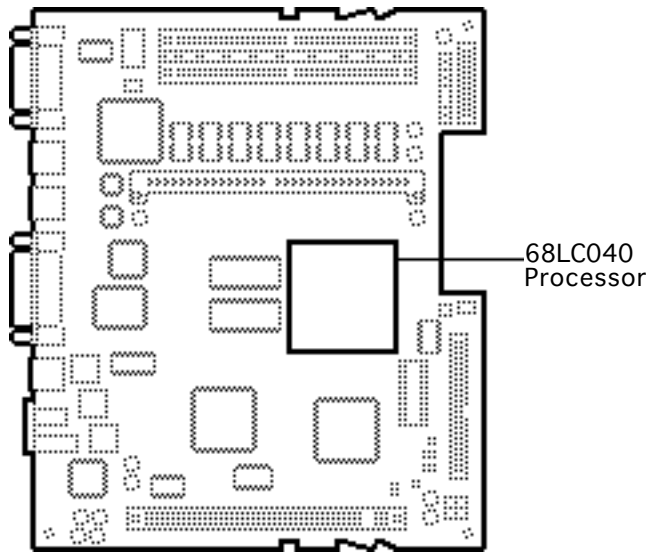

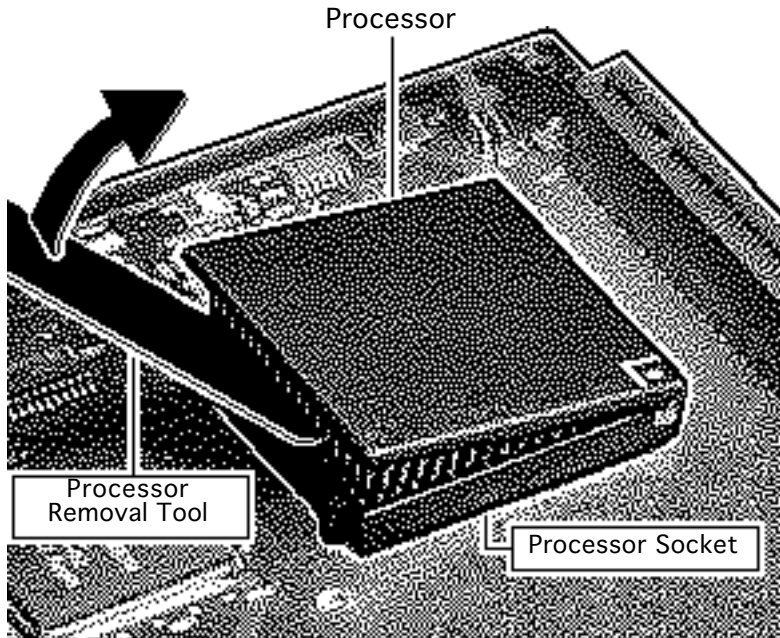

Note: This graphic shows the proper way to remove any 68LC040 chip from its logic board. Your logic board may differ somewhat from this graphic

- 3 Position the teeth of the processor removal tool in the groove between the processor and the logic board socket.





Caution: Be sure to lift up on the handle of the processor removal tool. Pressing down could damage components on the logic board.

Caution: Pry up each side of the processor only slightly to avoid bending the pins.

- 4 Gently lift up the processor removal tool handle and pry up each side of the processor from the socket.
- 5 Remove the processor.





Install the 68LC040 Processor on the Upgrade Board

Note: The alignment corner of the 68LC040 processor is missing one pin. The alignment corner of the spacer is missing a pin hole.

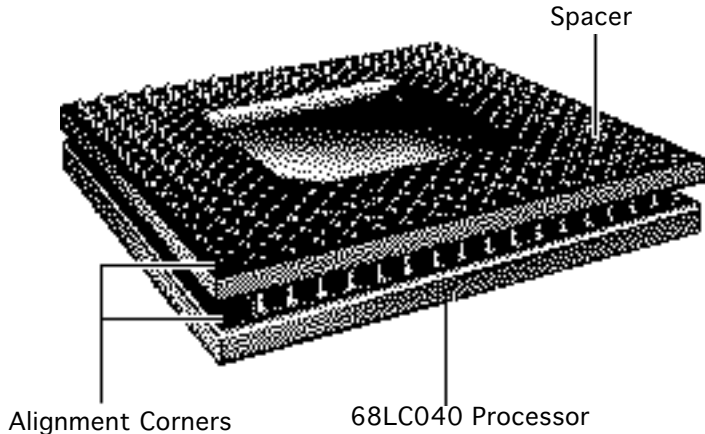

- 1 Position the spacer alignment corner over the 68LC040 processor alignment corner
- 2 Place the spacer on the processor.



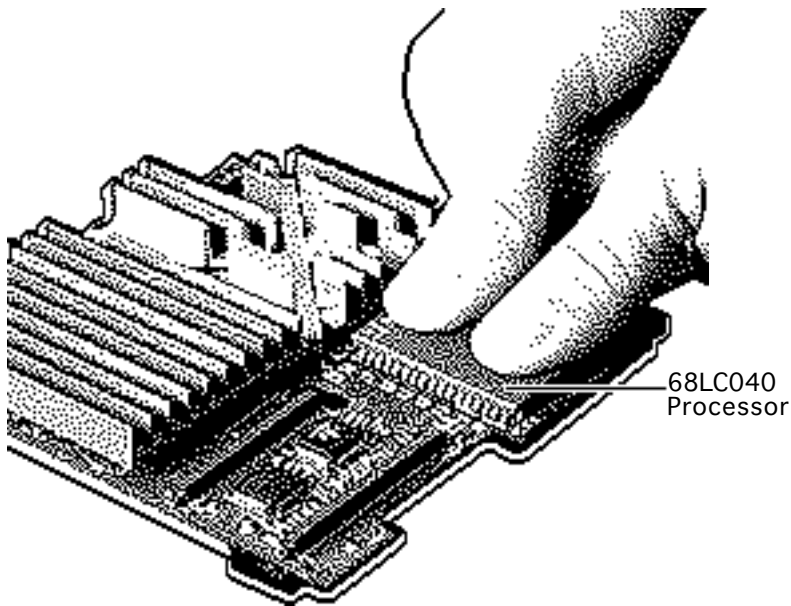

Caution: Forcing the 68LC040 processor connector pins into the socket could damage the pins. If the processor resists installation, check the pin alignment.

Caution: Place the upgrade board on a firm even surface to avoid bending the upgrade board when pressing the processor into the socket.

Caution: Use two thumbs to evenly distribute the pressure as you press the processor into the socket.





- 3 Hold the processor and spacer together and position the spacer alignment corner over the upgrade socket alignment corner.
- 4 Press the processor connector pins into the socket until you hear a “snap.”



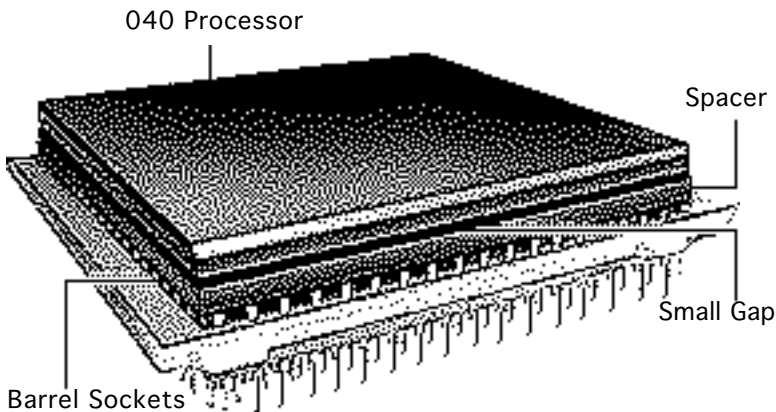

Note: On a correctly installed 040 processor, a very small gap separates the 040 chip from the metal spacer. A larger gap caused by the board barrel sockets separates the upgrade board and the spacer.



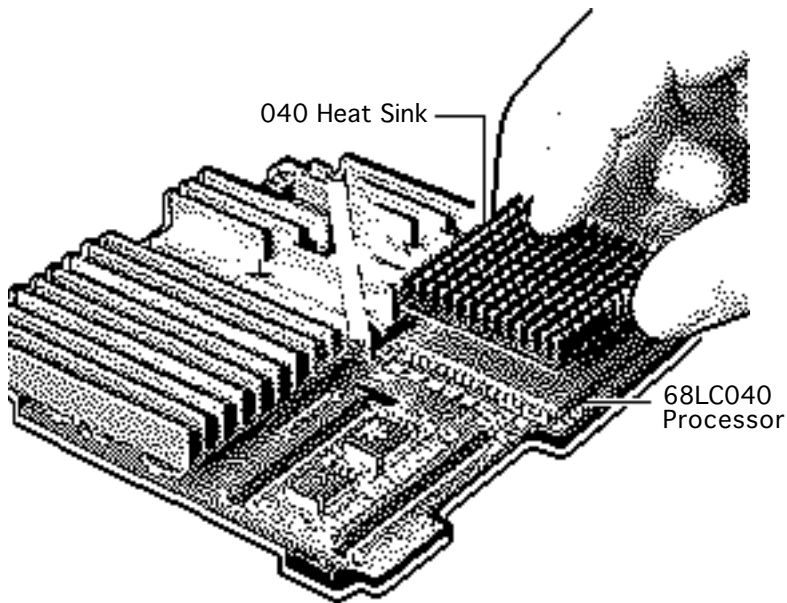

- 5 Peel the paper from the back of the heat sink and install the heat sink on the processor.

Note: Make sure the 040 heat sink is aligned with the sides of the processor.



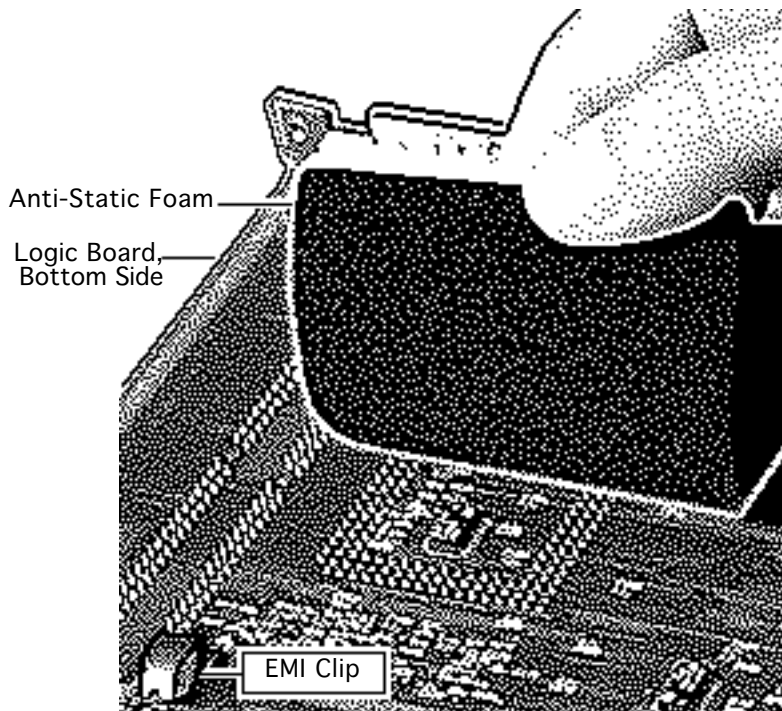

Install the Upgrade Board

Note: The next step explains how to prepare the logic board to accept the upgrade board.

Caution: The EMI clips on the bottom of the LC 475 and Quadra 605 logic boards flex easily. Do not apply heavy pressure directly to these clips or to the logic board, or you may bend the board.





- 1 Place a piece of antistatic foam directly under the processor socket on the bottom side of the logic board.

Note: This step helps prevent the logic board from bending when you apply pressure in the next few steps.



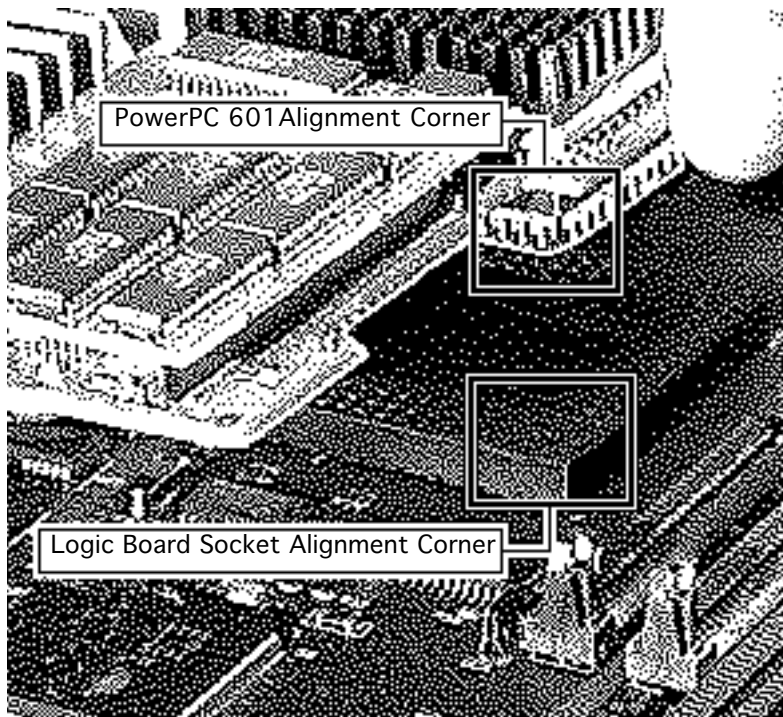

- 2 **Caution:** Forcing the upgrade board connector pins into the logic board socket could damage the pins. If the connector resists installation, check the pin alignment.

Position the upgrade connector alignment corner over the logic board socket alignment corner.

- 3 Carefully align the pins along all sides of the processor and socket.





- 4 Firmly press the connector pins into the logic board socket.

Note: To install the software, refer to the Macintosh Processor Upgrade Owner's Guide.





Logic Board and Upgrade Board Returns

Return the upgrade and logic boards to their original conditions before sending them to Apple. Be sure to remove the upgrade board from the logic board and reinstall the 68LC040 processor on the logic board.

Replacement Caution: To avoid bending any pins when removing the 68LC040 processor, pry up each side only slightly.





Additional Procedures

Macintosh LC Series/Quadra 605





Battery Verification

Before you begin, remove the top cover.

Caution: Review the ESD precautions in Bulletins/Safety.

Warning: If handled or discarded improperly, the lithium battery in the computer could explode. Review battery handling and disposal instructions in Bulletins/Safety.

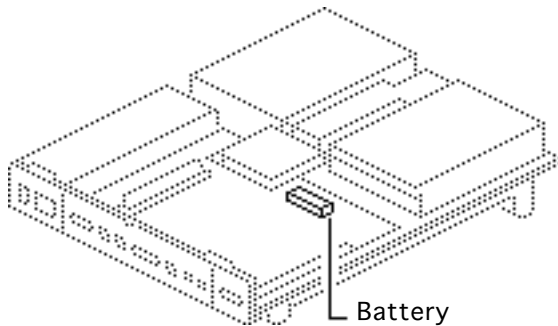

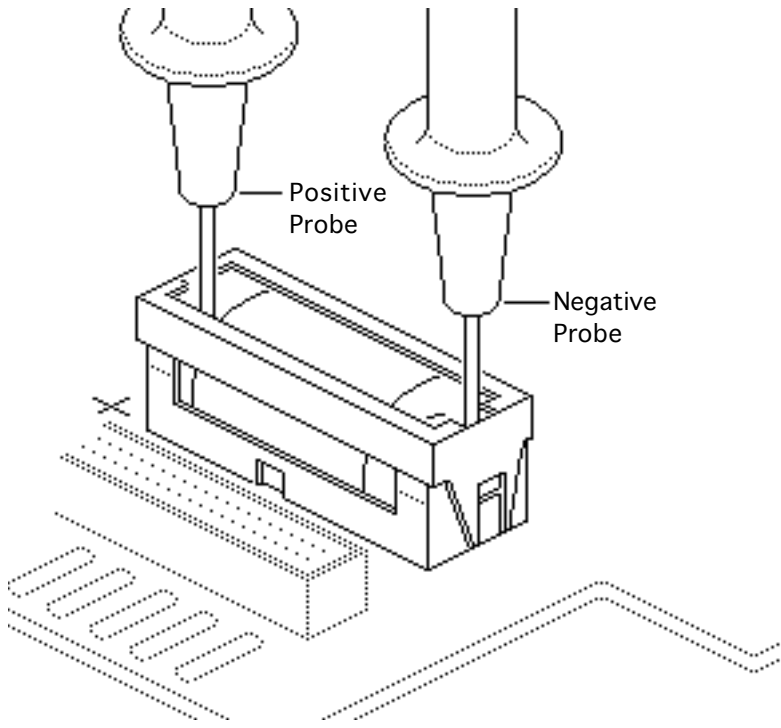

- 1 Set the voltmeter to the 10 volts DC scale.
- 2 Hold the positive probe of the voltmeter to the positive end of the battery and the negative probe to the negative end of the battery.
- 3 If the battery voltage is below 3.0 volts, replace the battery. Refer to “Battery Replacement” in this chapter.





Battery Replacement

Before you begin, remove the top cover.

Caution: Review the ESD precautions in Bulletins/Safety.

Warning: If handled or discarded improperly, the lithium battery in the computer could explode. Review battery handling and disposal instructions in Bulletins/Safety.

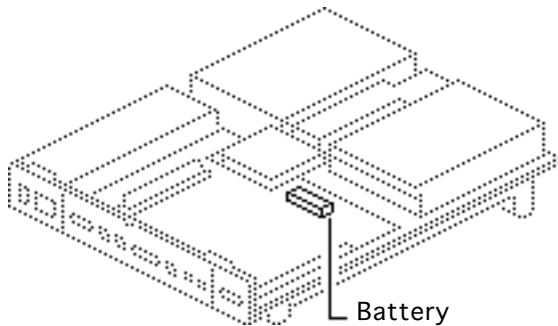

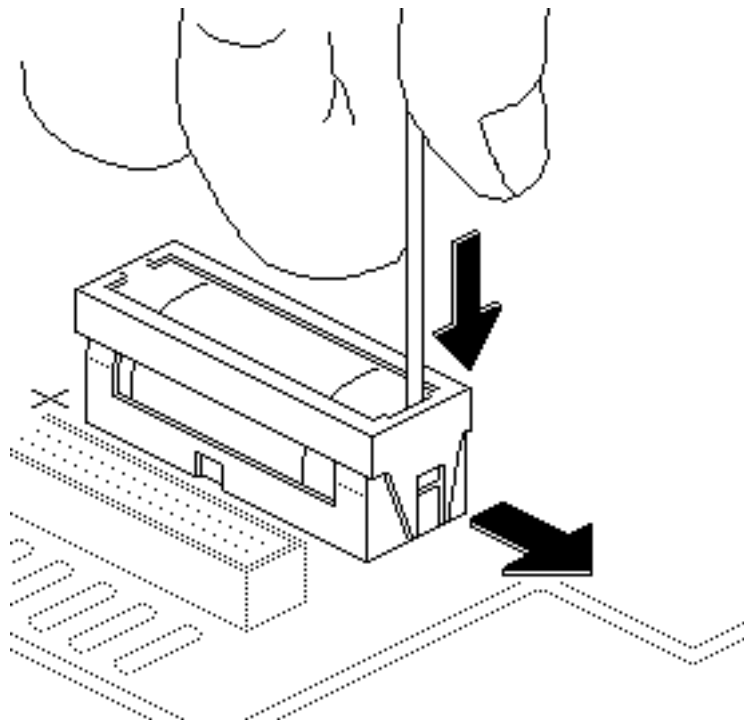

- 1 Insert a small flat-blade screwdriver into the top of the holder and gently push the screwdriver down until the side tab pushes out.
- 2 Repeat on the other end and remove the cover from the holder.



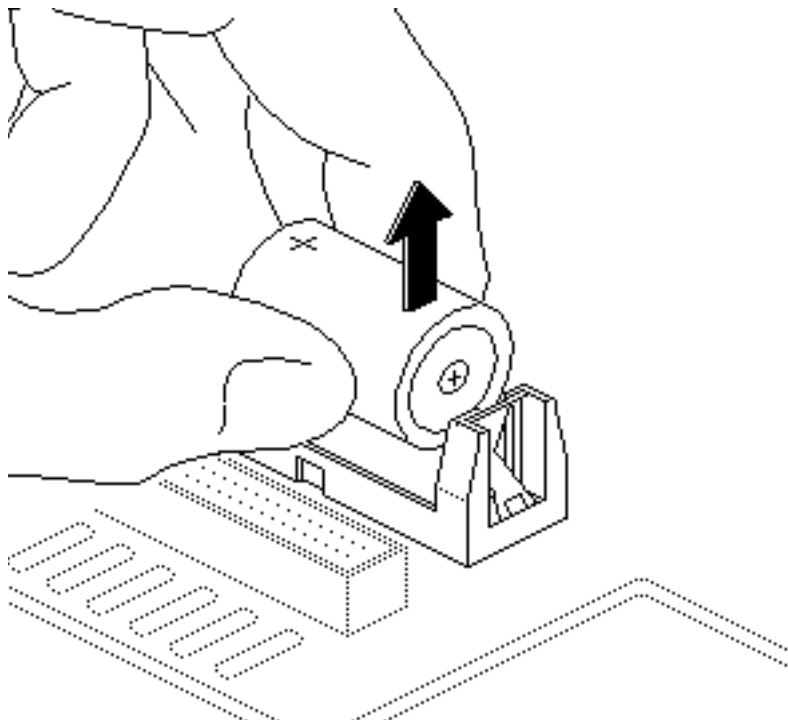

- 3 Grasp the battery and remove it from the holder.
- 4 Return the battery to Apple for proper disposal. For battery packaging and labeling information, refer to the instructions in Bulletins/Safety.





Exploded View

Macintosh LC Series, Quadra 605





Exploded View

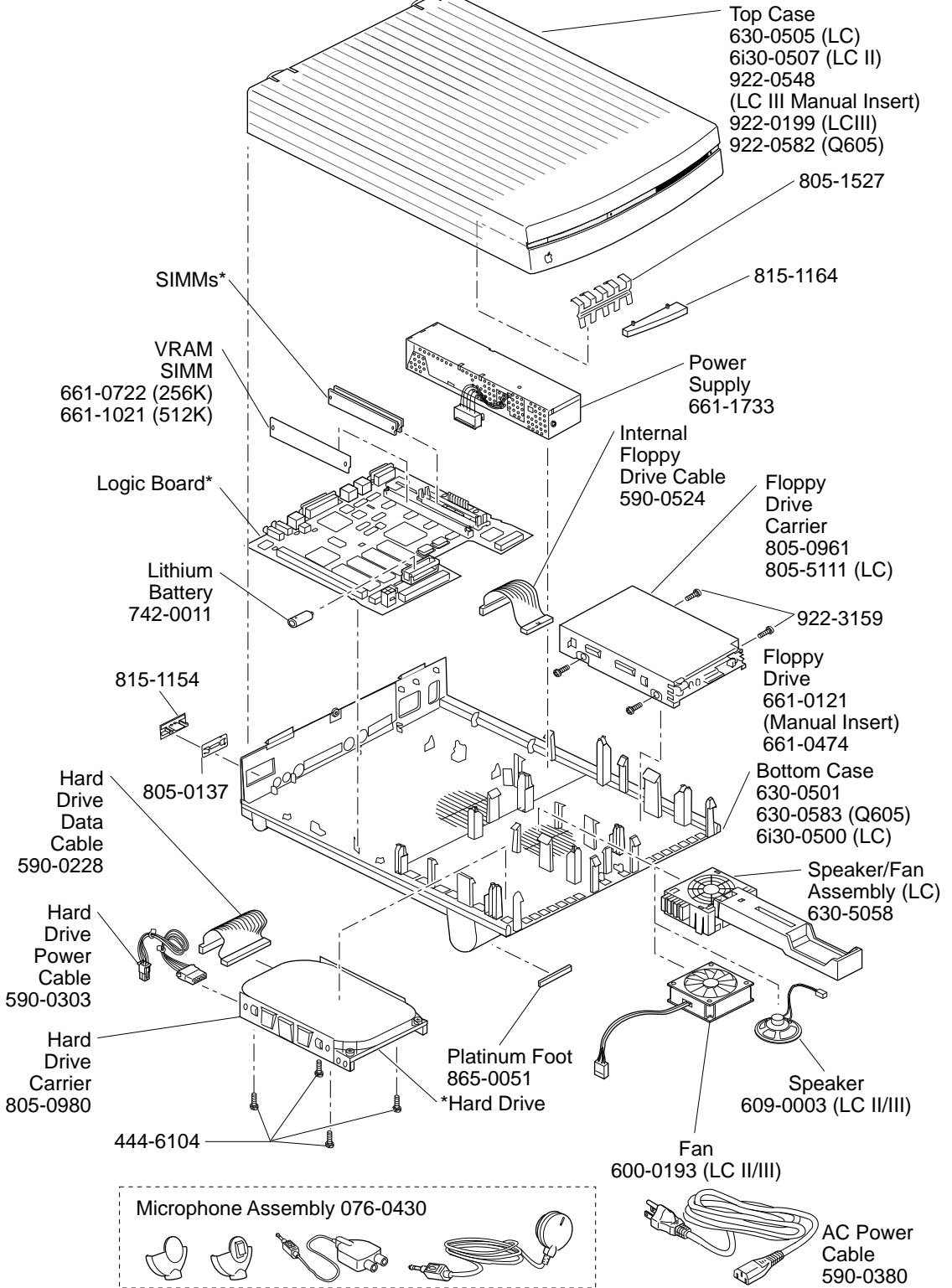

This is a generic representation of a product family. Configurations may vary. For number of part with asterisk, see parts list.

