



Performa 500 Series

Macintosh Performa 550, Macintosh Performa 560,
Macintosh Performa 575, Macintosh Performa 577,
Macintosh Performa 578





Basics

Performa 500 Series





Product Information

The Performa 500 Series computers are based on a compact “all-in-one” design. This design incorporates an LC-based microprocessor, 14-inch Trinitron display, CD-ROM drive, hard drive, and floppy drive in one enclosure.





Identifying Features

Performa 550 and 560:

- 68LC030 processor
- Processor-direct slot
- CD-300i drive (caddy required)

The Performa 550 and 560 ship with different software bundles.

Performa 575, 577, 578:

- 68LC040 processor
- Processor-direct and communications slots
- CD-300+i drive (trayloading, caddyless)
- Modem (third-party)

The Performa 575, 577 and 578 ship with slightly different software and hard drive bundles.





Specifications

Performa 500 Series





Processor

Performa 550, 560

Motorola 68030 microprocessor

33 MHz

Built-in memory management unit (MMU)

Performa 575, 577, 578

Motorola 68LC040 microprocessor

33 MHz

Built-in memory management unit (MMU)

Coprocessor

Socket for optional math coprocessor





Memory

RAM	Perf 550, 560: 4 MB of dynamic RAM on board Perf 575, 577: 5 MB of dynamic RAM on board Perf 578: 8 MB of dynamic RAM on board Expandable to 36 MB (80 ns or faster SIMMs) 72-pin DRAM SIMM connector
ROM	1 MB of ROM
PRAM	256 bytes of clock/calendar/parameter memory Long-life lithium battery





VRAM

Perf 550, 560: 512K of VRAM on board (up to 256 colors or 8-bit color)

Expandable to 768K (up to 32,000 colors or 16-bit color)
68-pin VRAM SIMM connector

Perf 575, 577,578: 1MB of VRAM onboard
Two VRAM SIMM slots





Disk Storage

Floppy Drive

Internal 1.4 MB Apple SuperDrive, manual-insert

Hard Drive

Perf 550, 560: 80 or 160 MB SCSI

Perf 575: 250 MB SCSI

Perf 577, 578: 320 MB SCSI

CD-ROM Drive

Perf 550, 560: Internal AppleCD 300i, double-speed CD-ROM drive

Perf 575, 577, 578: Internal AppleCD 300+i, double-speed CD-ROM drive





I/O Interfaces

Serial	Two RS-232/RS-422 serial ports; mini DIN-8 connectors
SCSI	One SCSI parallel port; DB-25 connector Connects up to six external SCSI devices
Apple Desktop Bus	Two Apple Desktop Bus (ADB) ports; mini DIN-4 connectors Maximum of three ADB devices recommended Maximum current draw: 500 mA (Mouse draws 10 mA, keyboard draws 25 mA)
Sound	Sound-output port capable of delivering stereo sound Sound-input port for monaural sound input Front headphone jack capable of delivering stereo sound





Processor-Direct Slot

Internal expansion slot for 96 or 114-pin processor-direct expansion cards

Communications Slot (Perf 575,577, 578)

Internal expansion slot for 50-pin modem and Ethernet cards





I/O Devices

Keyboard

Standard 80-key Apple keyboard with numeric keypad; ADB connector

Soft power-on switch

2.5 mm travel, 18 mm vertical and horizontal pitch

Two-level tilt adjustment

Mouse

Apple Desktop Bus Mouse II

New, ergonomic design

Microphone

Built-in electret, omnidirectional microphone

Speaker

Adjustable sound control on front of bezel





Sound and Video

Sound Generator

Records at 11 kHz or 22 kHz sample rate

Plays back at 11 kHz or 22 kHz sample rate

Two speakers with enhanced stereo sound

Allows playback and recording of ordinary audio compact discs

Video Display

14-in. diagonal, 13-in. viewable screen

Trinitron CRT with high-contrast glass

.26-mm aperture grille pitch

640 pixels by 480 lines; 70 dpi





Electrical

Line Voltage	100-240 VAC; Universal power supply
Frequency	47-63 Hz, single phase
Maximum Power	120 W





Physical

Dimensions

Height: 17.9 in. (45.5 cm)

Width: 13.5 in. (34.4 cm)

Depth: 16.5 in. (42.0 cm)

Weight

40.5 lb. (18.4 kg)





Environmental

**Operating
Temperature**

50-104° F (10-40° C)

**Storage
Temperature**

-40 to 116° F (-40 to 47° C)

Relative Humidity

20-95% noncondensing

Altitude

0-15,000 ft. (0-4722 m)





Troubleshooting

Performa 500 Series





General

The Symptom Charts included in this chapter will help you diagnose specific symptoms related to your product. Because cures are listed on the charts in the order of most likely solution, try the first cure first. Verify whether or not the product continues to exhibit the symptom. If the symptom persists, try the next cure. (Note: If you have replaced a module, reinstall the original module before you proceed to the next cure.)

If you are not sure what the problem is, or if the Symptom Charts do not resolve the problem, refer to the Flowchart for the product family.

For additional assistance, contact Apple Technical Support.





Symptom Charts

Video

Screen is black, too dark, or too bright; audio and drive operate

- 1 Adjust contrast button on front bezel.
- 2 Adjust brightness. Use Screen Control Panel.
- 3 Check yoke cable connection.
- 4 Perform video adjustments. Refer to “Video” in Adjustments chapter.
- 5 Replace analog board.
- 6 Replace CRT.

Screen is bright and audio is present, but no video information is visible

- 1 Perform video adjustments. Refer to “Video” in Adjustments chapter.
- 2 Replace analog board.
- 3 Replace CRT.





Video (Continued)

Single vertical or horizontal line is displayed

Note: A thin, gray, horizontal line may be visible across the bottom third of a lit screen. This line is inherent in the design of Trinitron monitors. Do not replace modules.

Otherwise,

- 1 Replace analog board.
- 2 Replace CRT.

Predominant color tint or color cannot be adjusted

- 1 Perform video adjustments. Refer to “Video” in Adjustments chapter.
- 2 Replace analog board.
- 3 Replace CRT if red, green, or blue cannot be turned off using appropriate controls.





Video (Continued)

Picture breaks into diagonal lines, or picture rolls vertically or horizontally

- 1 Perform video adjustments. Refer to “Video” in Adjustments chapter.
- 2 Replace analog board.

Out of convergence (color bleeds from text or lines)

- 1 Perform convergence adjustment. Refer to “Convergence” in Adjustments chapter.
- 2 Replace analog board.
- 3 Replace CRT.

Black screen spots (burnt phosphors)

Replace CRT.





Video (Continued)

Screen jitters or flashes

- 1 Verify that adjacent computer equipment is properly grounded. Move electrical devices away from monitor. Temporarily shut off all fluorescent lights in area.
- 2 Check that all ground cables are secure.
- 3 Replace analog board.

Out of focus

- 1 Perform focus adjustment. Refer to “Focus” in Adjustments chapter.
- 2 Replace analog board.
- 3 Replace CRT only if one part of display remains out of focus despite adjustment of focus controls to their limits.





Video (Continued)

Flashing or wavy screen or monitor emits high-pitched noise

Replace analog board.

Raster size too short/tall or narrow/wide

- 1 Adjust horizontal or vertical size control. Refer to Adjustments chapter.
- 2 Replace analog board.

Linearity bad (size of text/graphics differs at top, bottom, or sides of screen)

- 1 Perform video adjustments. Refer to “Video” in Adjustments chapter.
- 2 Replace analog board.





Video (Continued)

Raster tilted or shifted

- 1 Verify that adjacent computer equipment is properly grounded. Move electrical devices away from monitor. Temporarily shut off all fluorescent lights in area.
- 2 Perform appropriate geometric adjustments in Adjustments chapter.
- 3 Perform yoke adjustment. Refer to “Yoke” in Adjustments chapter.
- 4 Replace analog board.

Raster distorted (barrel-shaped, corners not square, stretched or compressed at top of display, or sides not perpendicular)

- 1 Verify that adjacent computer equipment is properly grounded. Move electrical devices away from monitor. Temporarily shut off all fluorescent lights in area.
- 2 Perform appropriate geometric adjustments in Adjustments chapter.
- 3 Replace analog board.
- 4 Replace CRT (only in rare instances).





Video (Continued)

Raster not centered

- 1 Verify that adjacent computer equipment is properly grounded. Move electrical devices away from monitor. Temporarily shut off all fluorescent lights in area.
- 2 Adjust horizontal or vertical center control. Refer to Adjustments chapter.
- 3 Replace analog board.





Floppy Drive

Audio and video are present, but internal floppy drive does not operate

- 1 Replace bad disk with known-good disk.
- 2 Replace floppy drive.
- 3 Replace logic board. Retain customer's SIMMs.
- 4 Replace floppy drive.

Disk ejects; display shows icon with blinking "X"

- 1 Replace bad system disk with known-good system disk.
- 2 Replace floppy drive.
- 3 Replace logic board. Retain customer's SIMMs.

Unable to insert disk all the way

- 1 To eject previously inserted disk, insert opened paper clip into hole beside floppy drive.
- 2 Switch off system and hold mouse button down while switching system on (to complete eject cycle).
- 3 Replace floppy drive.





Floppy Drive (Continued)

Does not eject disk

- 1 Insert opened paper clip into hole beside floppy drive.
- 2 Switch off system and hold mouse button down while switching system on (to complete eject cycle).
- 3 Replace floppy drive.

Internal floppy drive runs continuously

- 1 Replace bad disk with known-good disk.
- 2 Replace floppy drive.
- 3 Replace logic board. Retain customer's SIMMs.
- 4 Replace floppy drive.





Hard Drive

Internal or external hard drive does not operate

- 1 Verify that SCSI loopback card is not attached.
- 2 Verify that external drive is properly terminated.
- 3 Replace hard drive.
- 4 Replace logic board. Retain customer's SIMMs.
- 5 Replace hard drive.

Works with internal or external SCSI device but does not work with both

- 1 Verify that SCSI device ID switch setting on external device is higher than 0. Also verify that ID switch setting on external SCSI device does not duplicate ID switch settings on any other attached external SCSI devices.
- 2 Replace terminator on external SCSI device.
- 3 Replace SCSI select cable.





CD-ROM Drive

CD-ROM drive does not accept disc

- 1 Replace disc (if dirty or damaged).
- 2 Replace CD-ROM drive mechanism.

Volume control does not operate correctly

Replace chassis harness assembly.

Macintosh cannot mount CD-ROM drive

Replace CD-ROM drive mechanism.





Peripheral

Cursor does not move

- 1 Check mouse connection.
- 2 If mouse was connected to keyboard, connect it to rear ADB port instead. If mouse works, replace keyboard.
- 3 If mouse does not work in any ADB port, replace mouse.
- 4 Replace logic board. Retain customer's SIMMs.

Cursor moves, but clicking mouse button has no effect

- 1 Replace mouse.
- 2 Replace logic board. Retain customer's SIMMs.





Peripheral (Continued)

Cannot double-click to open application, disk, or server

- 1 Remove extra system files on hard drive.
- 2 Clear parameter RAM. Hold down <Command> <Option> <P> <R> keys during system startup but before “Welcome to Macintosh” appears.
- 3 If mouse was connected to keyboard, connect it to rear ADB port instead. If mouse works, replace keyboard.
- 4 If mouse does not work in any ADB port, replace mouse.
- 5 Replace logic board. Retain customer’s SIMMs.

No response to any key on keyboard

- 1 Check keyboard connection to ADB port.
- 2 Replace keyboard cable.
- 3 Replace keyboard.
- 4 Replace logic board. Retain customer’s SIMMs.





Peripheral (Continued)

Known-good
ImageWriter or
ImageWriter II does
not print

- 1 Make sure that Chooser and Control Panel are set correctly.
- 2 Replace printer driver and system software with known-good.
- 3 Replace printer interface cable.
- 4 Replace logic board. Retain customer's SIMMs.

Known-good
LaserWriter does not
print

- 1 Make sure that Chooser and Control Panel are set correctly.
- 2 Replace printer driver and system software with known-good.
- 3 Refer to Networks and Communications manual.





Miscellaneous

Clicking, chirping, or thumping sound	1	Replace analog board.
	2	Replace logic board. Retain customer's SIMMs.
Smoke/odor		Replace analog board.
No video, no audio, and no drive operation	1	Connect power cord.
	2	Switch power on.
	3	Replace power cord.
	4	Replace analog board.
	5	Replace logic board. Retain customer's SIMMs.
"Sad Macintosh" icon	1	Replace bad disk with known-good disk.
	2	Replace RAM SIMMs on logic board.
	3	Replace logic board. Retain customer's SIMMs.





Miscellaneous (Continued)

- | | | |
|------------------------------------------------------------------------------|---|------------------------------------------------|
| Screen shows “Sad Macintosh” icon and black vertical lines; screeching sound | 1 | Replace RAM SIMMs on logic board. |
| | 2 | Replace logic board. Retain customer’s SIMMs. |
| Headphone jack does not operate correctly | 1 | Verify that headphone jack is seated properly. |
| | 2 | Replace chassis harness assembly. |
| Speaker jacks do not operate | 1 | Verify that speaker jacks are seated properly. |
| | 2 | Replace chassis harness assembly. |





Take Apart

Performa 500 Series



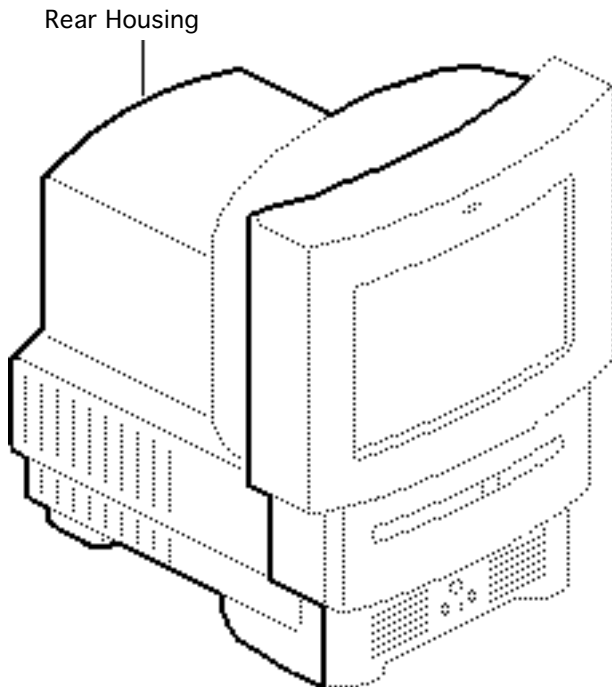

Rear Housing

No preliminary steps are required before you begin this procedure.

⚠ Warning: This product contains high voltage and a high-vacuum picture tube. To prevent serious personal injury or equipment damage, review CRT safety in Bulletins/Safety.

⚠ Warning: Never use a grounding wriststrap until after discharging the CRT.



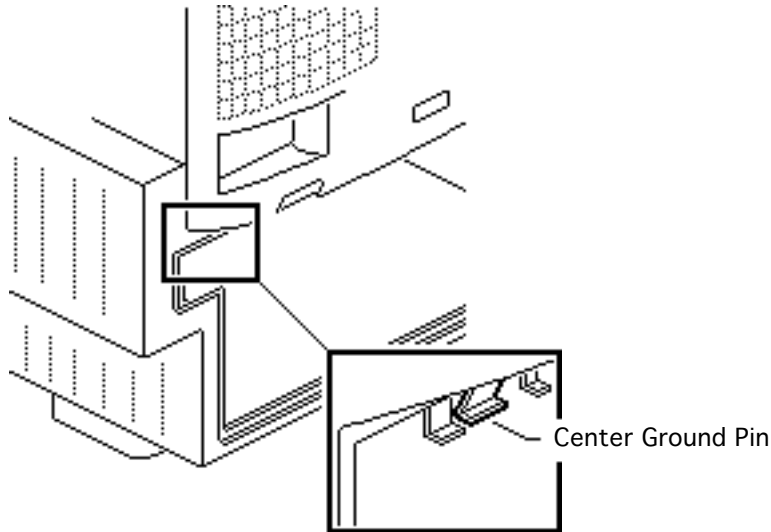

Note: If the rear housing has bronze tape on the rear housing shield, remove the tape before removing the rear housing. Bend back the center ground pin on the rear housing shield about 1/8 inch. Do not replace the bronze tape.



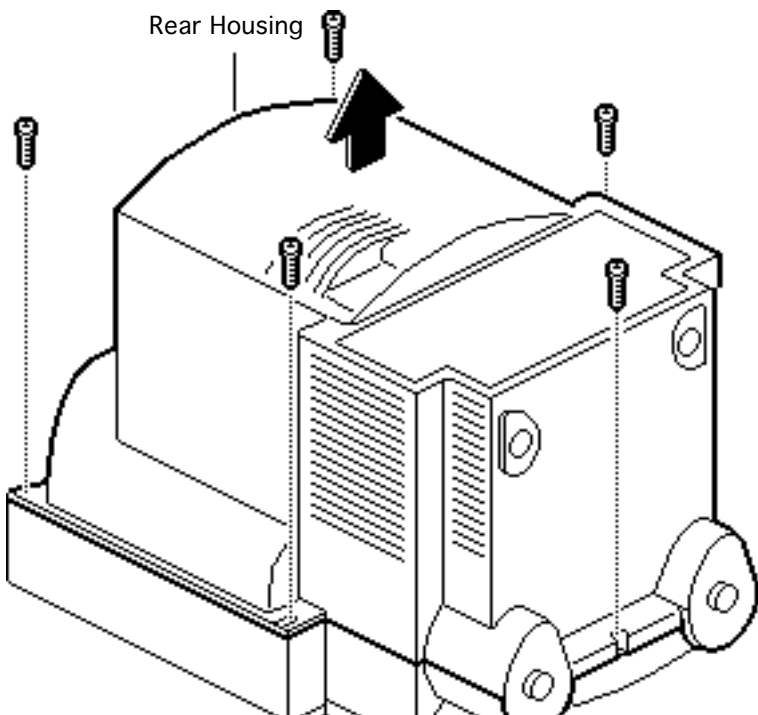

- 1 Using a Torx screwdriver, remove the five screws.
- 2 Lift off the rear housing.



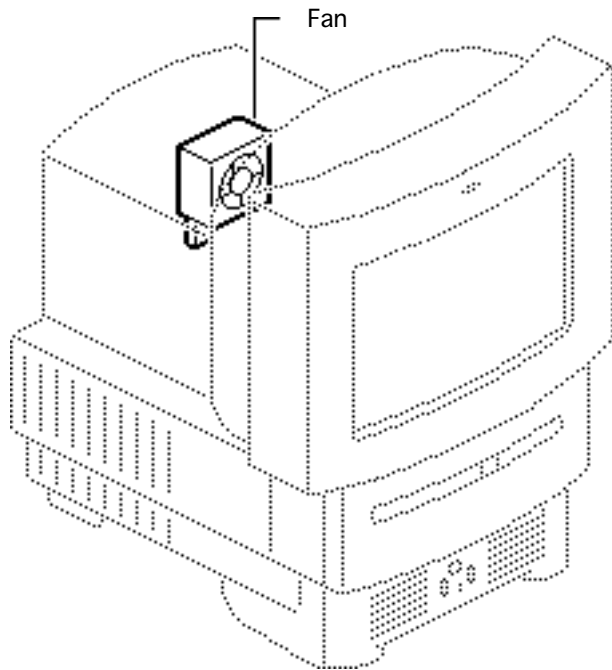

Fan

Before you begin, remove the rear housing.

⚠ Warning: This product contains high voltage and a high-vacuum picture tube. To prevent serious personal injury or equipment damage, review CRT safety in Bulletins/Safety.

⚠ Warning: Never use a grounding wriststrap until after discharging the CRT.



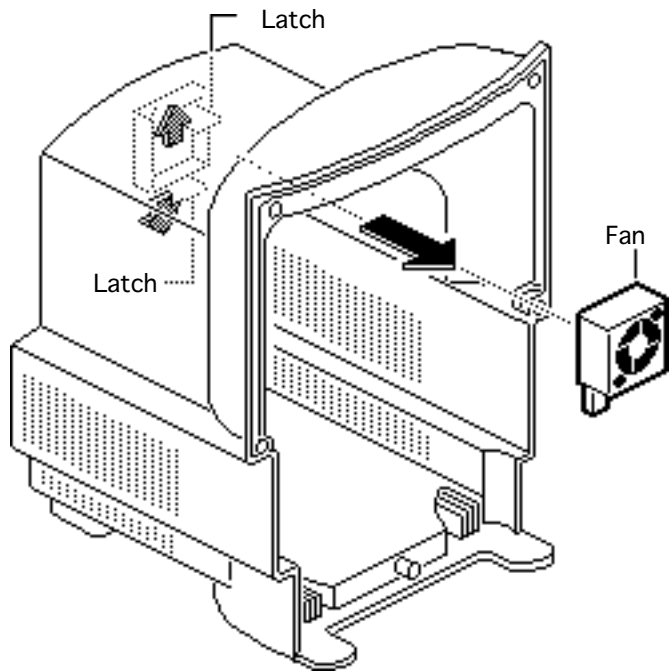

Push out the two latches and remove the fan assembly.





Analog Board

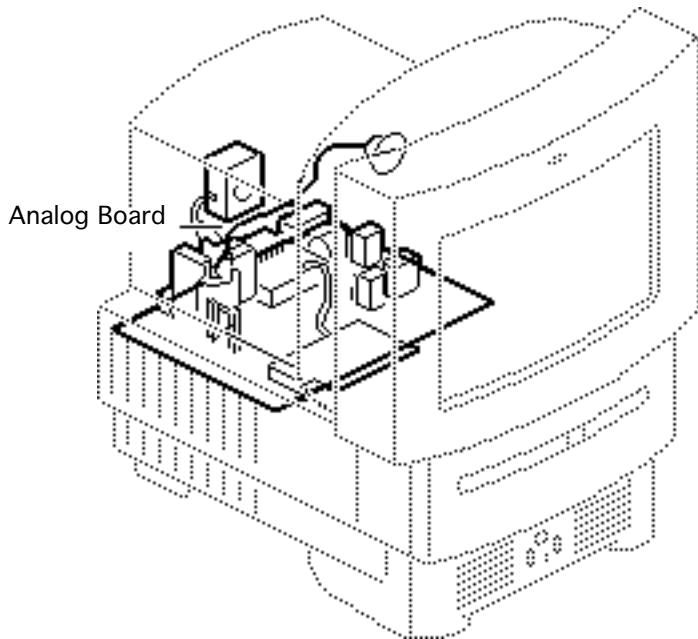

Before you begin,

- Remove the rear housing
- Discharge the CRT
- Remove the anode cap

⚠ Warning: This product contains high voltage and a high-vacuum picture tube. To prevent serious personal injury or equipment damage, review CRT safety in Bulletins/Safety.

⚠ Warning: Never use a grounding wriststrap until after discharging the CRT.



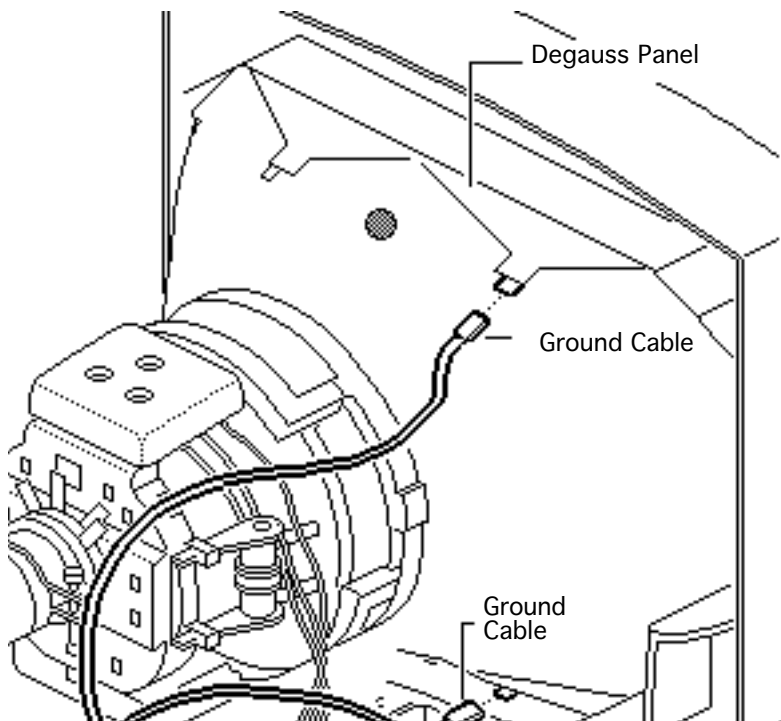

- 1 Disconnect the two ground cables from the degauss panels.





- 2 Disconnect the internal microphone connector.

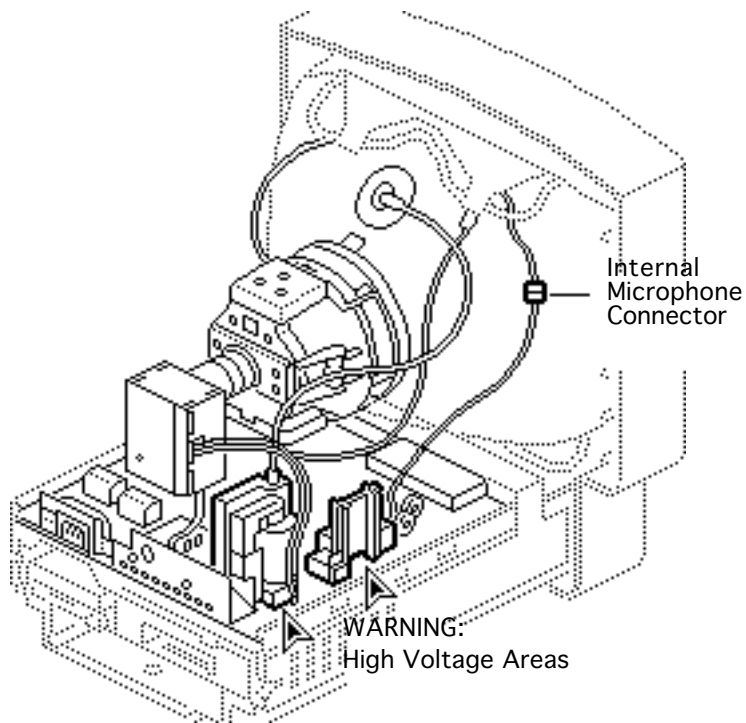

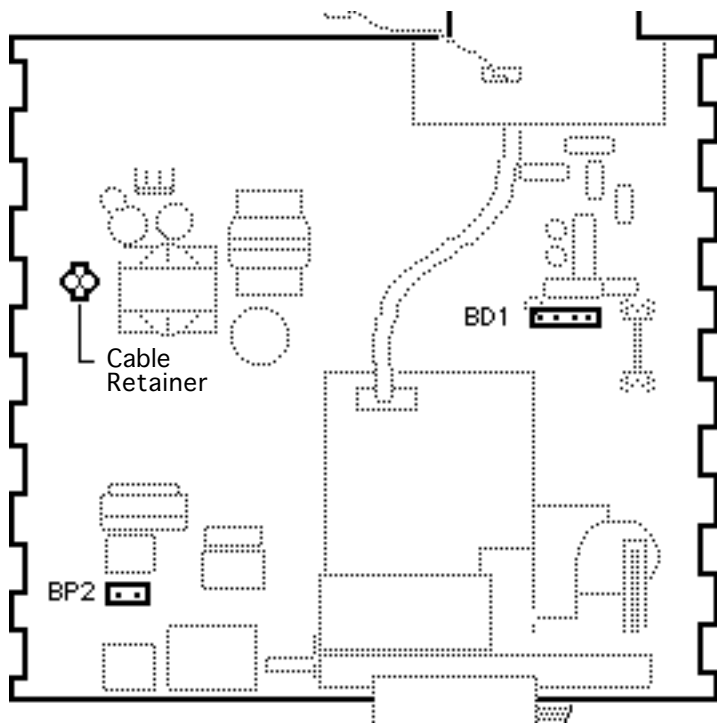

- 3 Disconnect the following cables from the analog board:
 - Degauss cable from BP2 (use a small screwdriver to release the latch)
 - CRT cable from BD1
- 4 Remove the wires from the cable retainer.

Replacement Note: If you are replacing the analog board, remove the cable retainer and reinstall it on the new board.



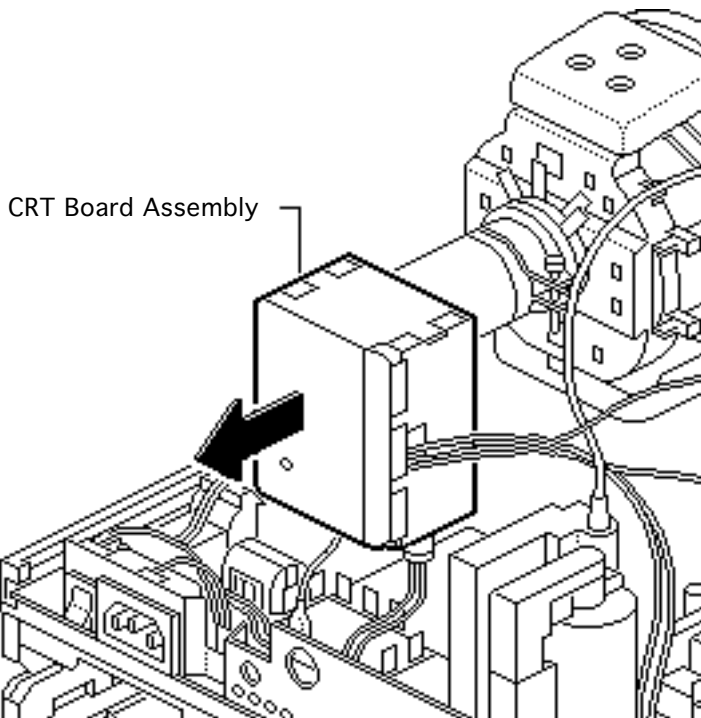

- 5 **Caution:** Twisting, bending, or applying force to the video board assembly could damage the neck of the CRT. Be sure to pull the CRT board assembly straight off the CRT.

Remove the CRT board assembly from the neck of the CRT.





6 Remove the analog board.

Replacement Note: Perform the cutoff adjustment whenever you replace the analog board. See “Video” in the Adjustments chapter.

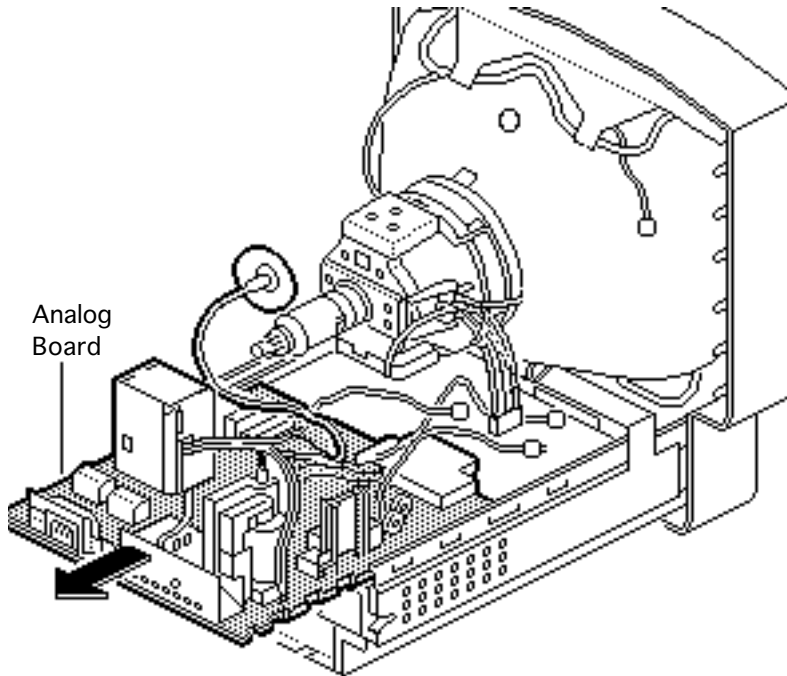



I/O Door

No preliminary steps are required before you begin this procedure.

Caution: Review the ESD precautions in Bulletins/ Safety.

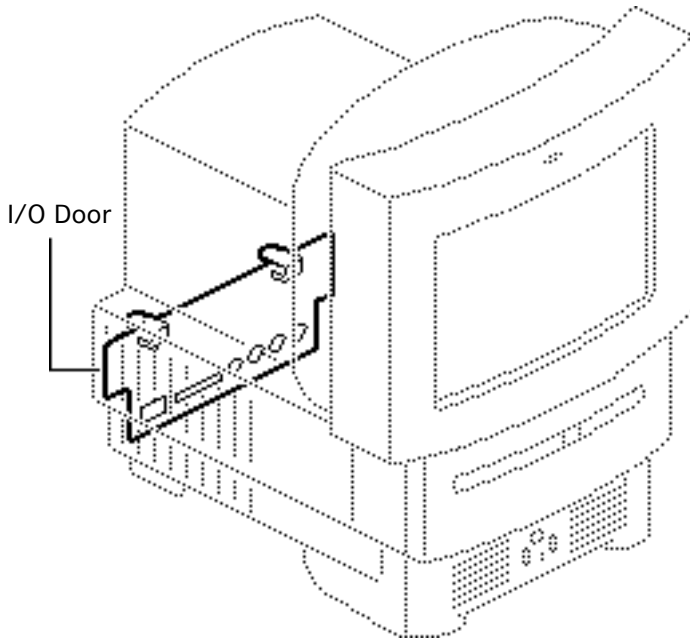



- 1 Remove the two screws.
- 2 Push down on the two tabs and remove the I/O door.

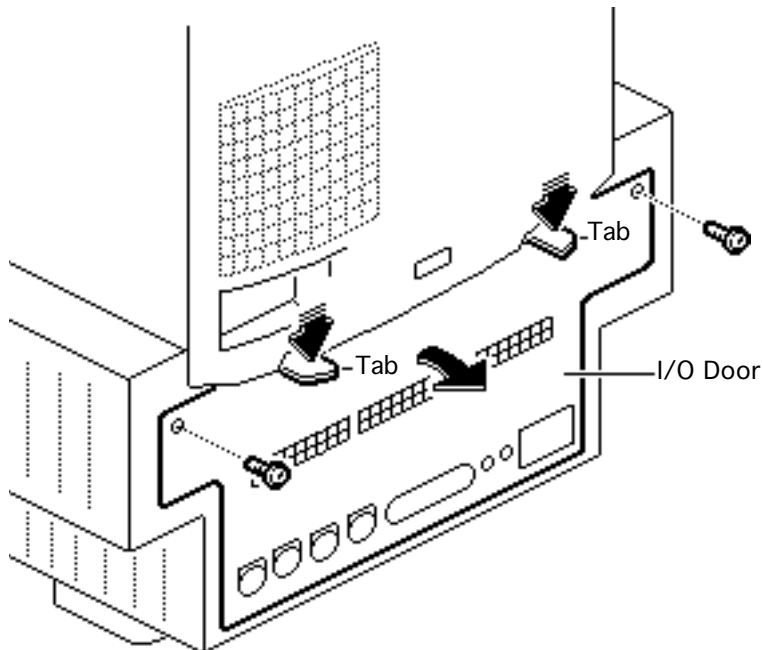



Logic Board

Before you begin, remove the I/O door.

Caution: Follow proper ESD precautions: use a grounded workbench pad, and always wear a grounding wriststrap.

Pull out the logic board.

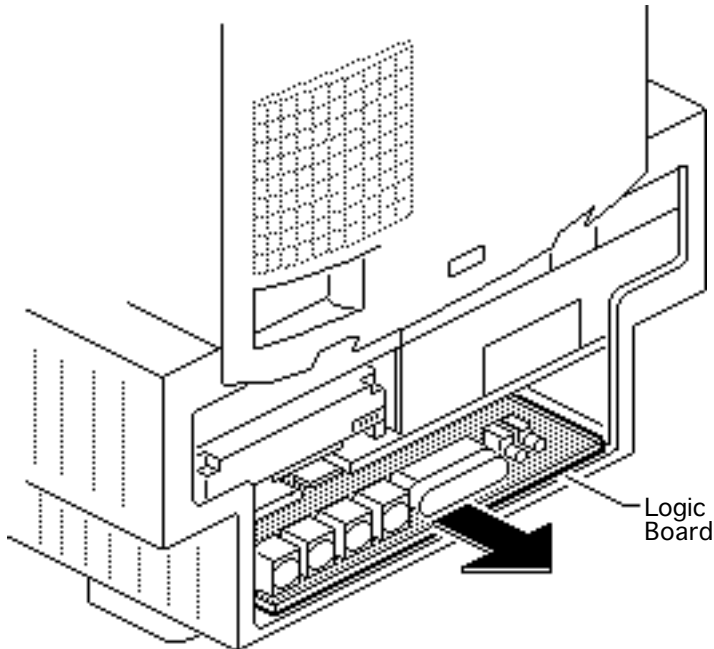



Drive Bezel

No preliminary steps are required before you begin this procedure.

Caution: Review the ESD precautions in Bulletins/ Safety.

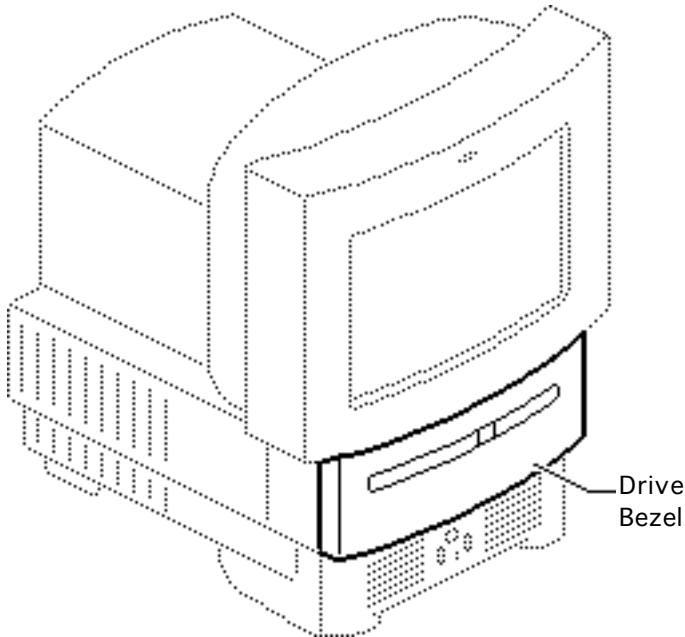

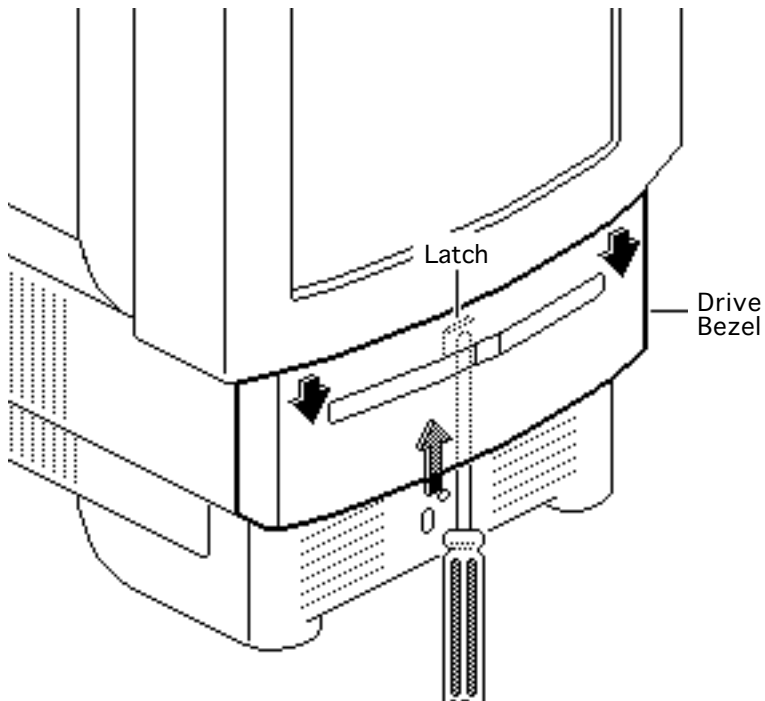

Using a flat-blade screwdriver, push up the latch. Pull down and remove the drive bezel.





Floppy Drive

Before you begin, remove the drive bezel.

Caution: Follow proper ESD precautions: use a grounded workbench pad, and always wear a grounding wriststrap.

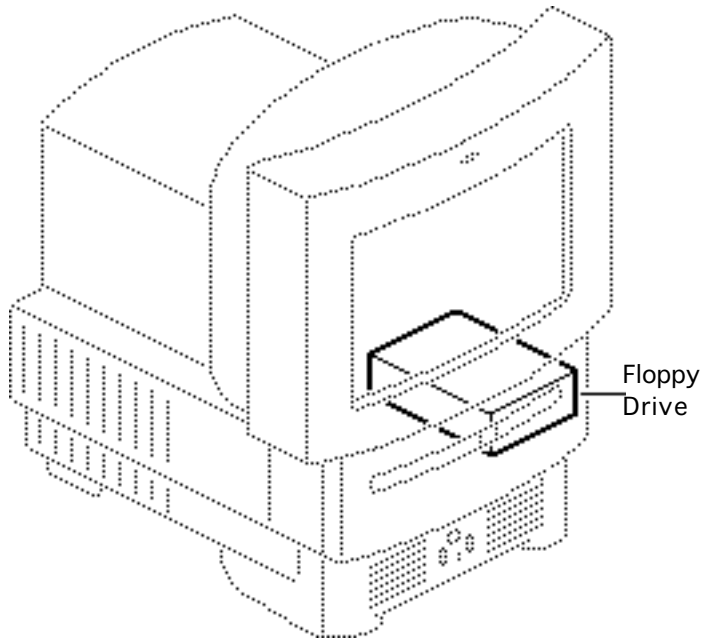



- 1 Push down the latch and pull out the floppy drive.

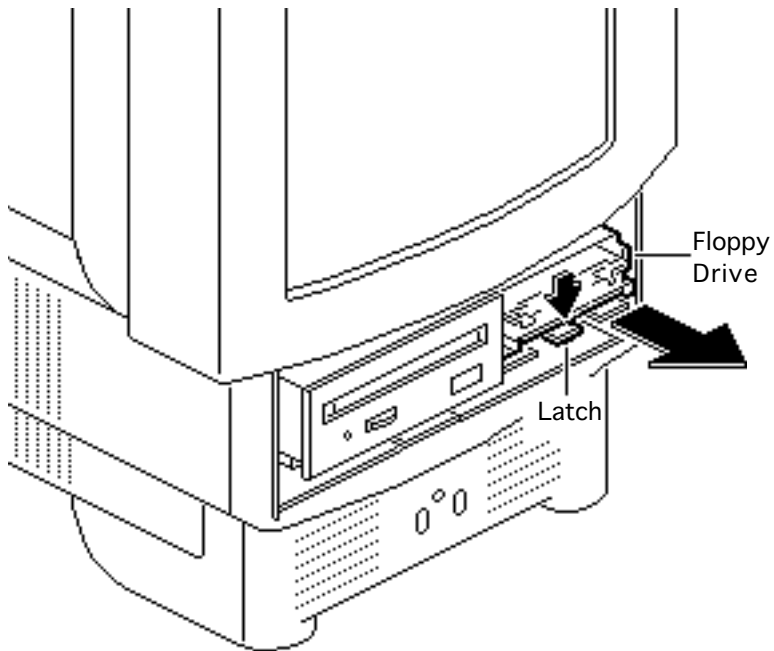



- 2 Pull out the floppy drive connector adapter.

Connector
Adapter

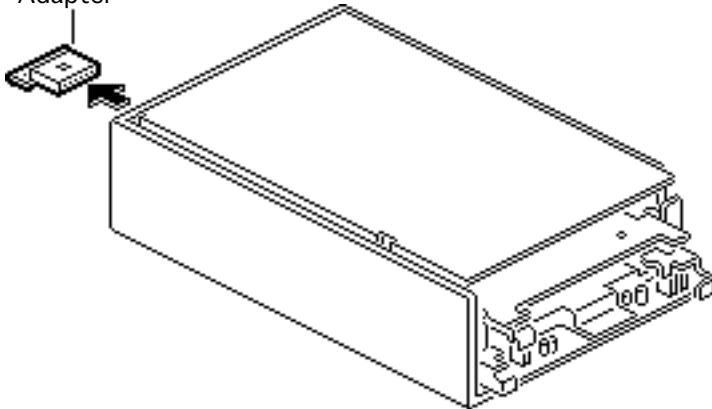

Replacement Note: Be sure to reinstall the floppy drive connector adapter on the replacement floppy drive.



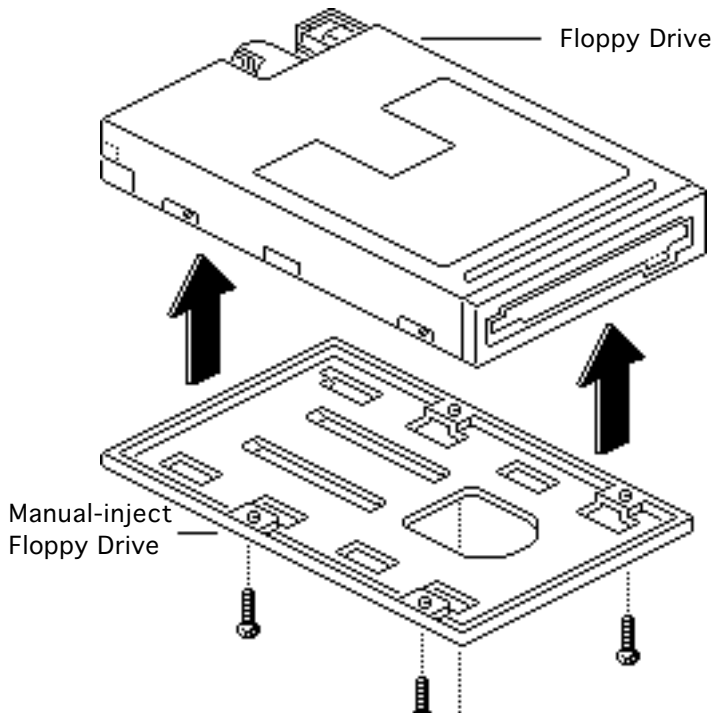

- 3 Remove the four mounting screws and remove the floppy drive from the carrier.





CD-ROM Drive

Before you begin, remove the drive bezel.

Caution: Follow proper ESD precautions: use a grounded workbench pad, and always wear a grounding wriststrap.

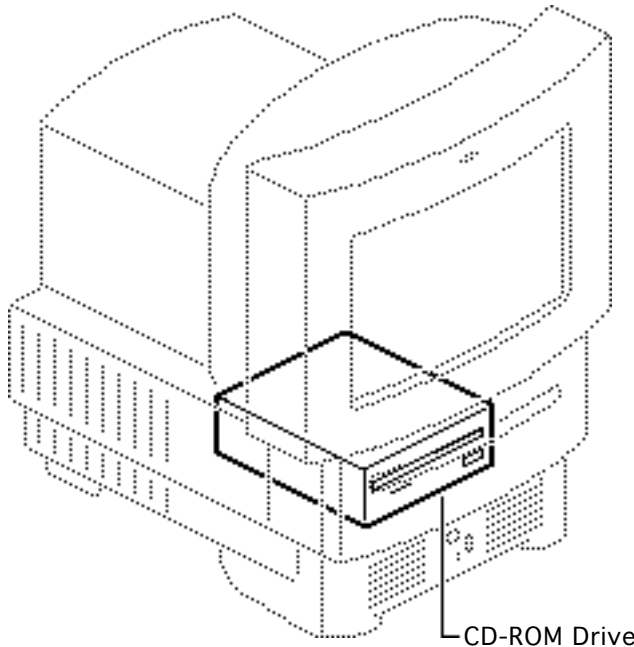

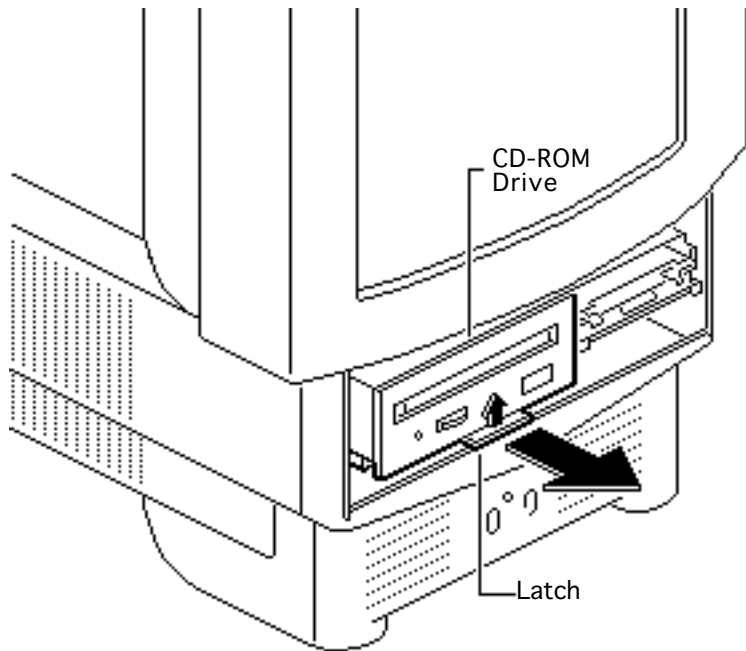

- 1 Pull up the latch and pull out the CD-ROM drive.





- 2 Pull out the CD connector adapter and the CD audio adapter.

Replacement Note: Be sure to reinstall the CD connector adapter on the replacement CD-ROM drive.

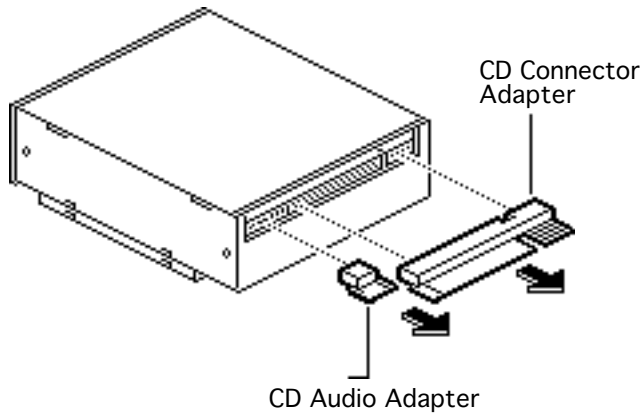

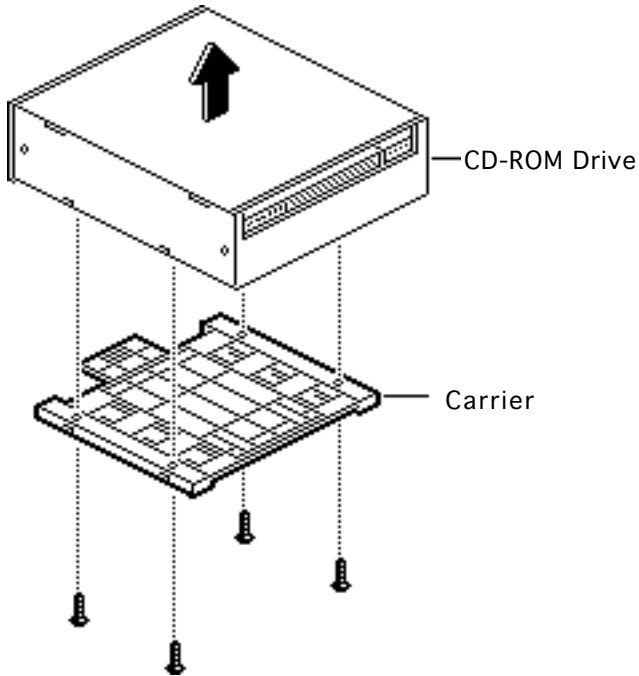

- 3 Remove the four mounting screws and remove the CD-ROM drive from the carrier.

Replacement Note: Replace the carrier on the new CD-ROM drive.





Hard Drive

Before you begin, remove the I/O door.

Caution: Follow proper ESD precautions: use a grounded workbench pad, and always wear a grounding wriststrap.

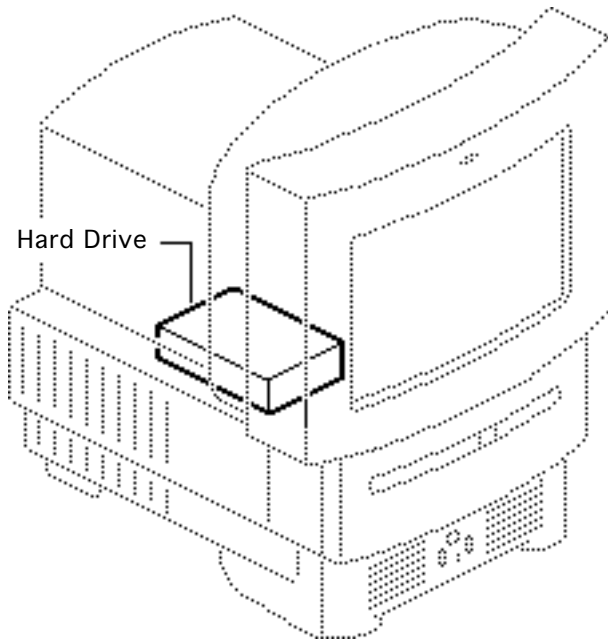



- 1 Push down the latch and remove the hard drive.

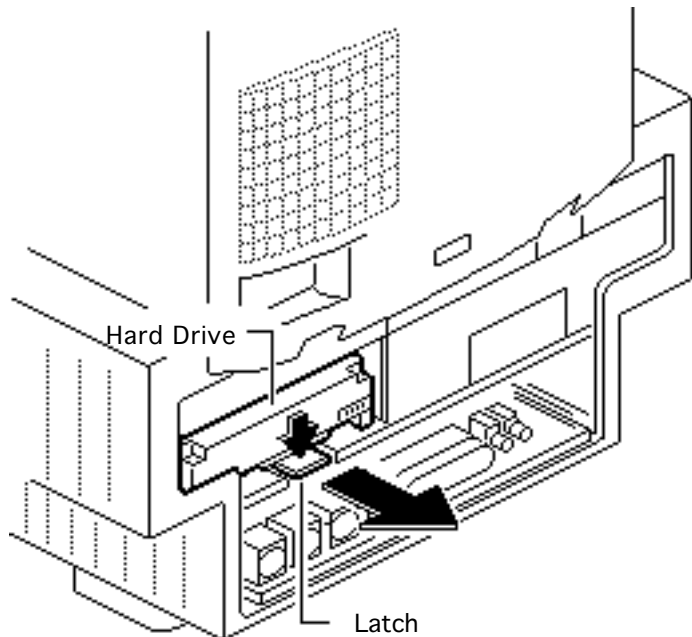



- 2 Pull out the hard drive connector adapter.

Replacement Note: Be sure to reinstall the hard drive connector adapter on the replacement hard drive.

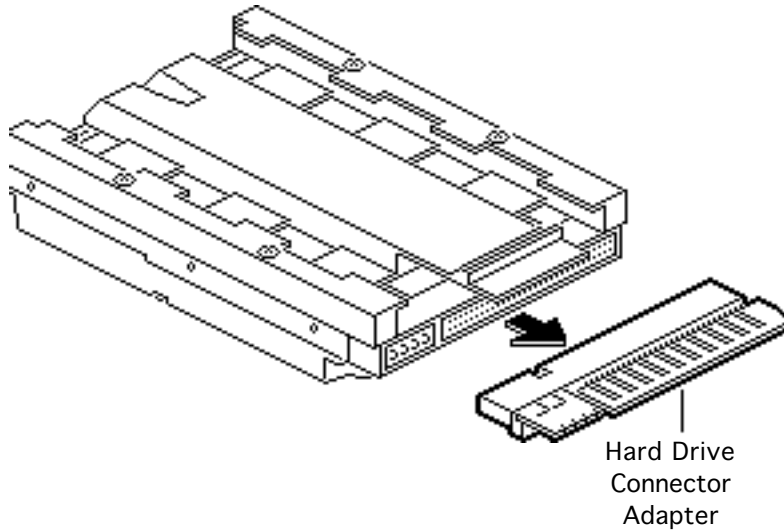

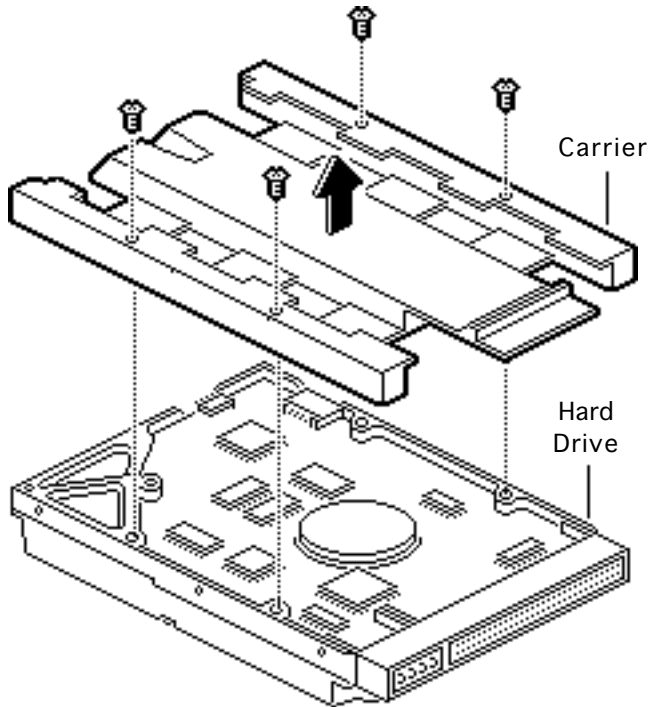

- 3 Remove the four screws.
- 4 Remove the hard drive from the carrier.

Replacement Note: Replace the carrier on the new hard drive.





Chassis Harness Assembly

Before you begin, remove the following:

- Drive bezel
- I/O door
- CD-ROM drive
- Floppy drive
- Hard drive
- Logic board
- Rear housing
- Analog board

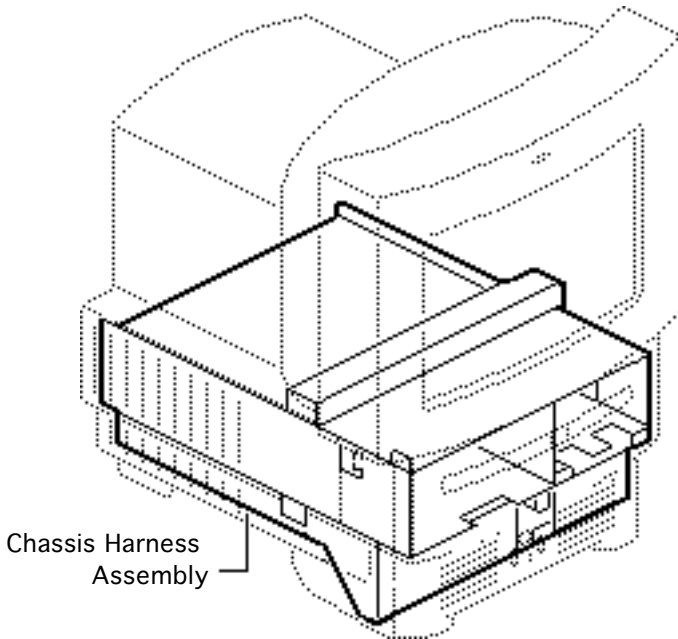

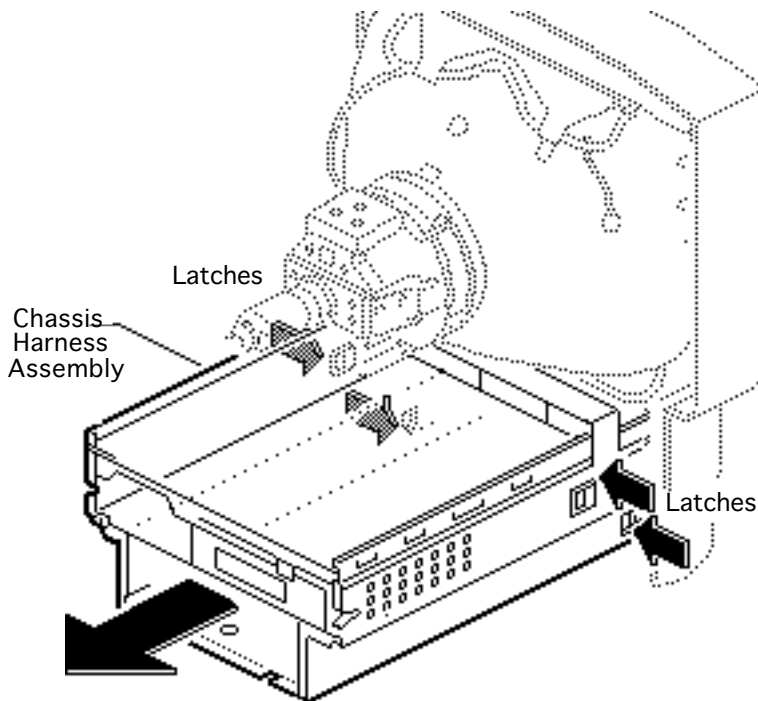

⚠ Warning: This product contains high voltage and a high-vacuum picture tube. To prevent serious personal injury or equipment damage, review CRT safety in Bulletins/Safety.

⚠ Warning: Never use a grounding wriststrap until after discharging the CRT.

- 1 Discharge the CRT.
- 2 Press in the four latches and lift off the chassis harness assembly.





Chassis Harness Take Apart Strategy

Background

After product introduction, Apple Service adjusted the service strategy for the chassis harness assembly in Mac TV, LC 500 Series, and Performa 500 Series computers. Originally, the chassis harness assembly was a single service assembly. As of November 1994, the chassis harness assembly is divided into several service piece parts.

Identifying the Chassis Harness Assembly

There are three slightly different chassis harness assemblies and Apple service strategy varies with the type of chassis. The three chassis harness assemblies differ according to the combination of floppy and CD-ROM drives they support.





- Chassis 922-1824 supports the auto-insert Apple SuperDrive and CD-ROM drives earlier than the 300i+. This chassis requires a floppy drive adapter, and the CD-ROM connector bridge is about 1-1/2 inches above the CD-ROM drive bay.
- Chassis 922-0557 supports the manual-insert Apple SuperDrive and CD-ROM drives earlier than the 300i+. This chassis uses a ribbon cable to connect the floppy drive, and the CD-ROM connector bridge is about 1-1/2 inches above the CD-ROM drive bay.
- Chassis 661-1094 supports the manual-insert Apple SuperDrive and the 300i+ CD-ROM drive. This chassis uses a ribbon cable to connect the floppy drive, but the CD-ROM connector bridge is only 1/2 inch above the CD-ROM drive bay.





For more information, refer to *Apple Service Guide*, Macintosh Computers, Vol. 3 (1994), page 110.

Service Parts Now Available for Chassis 922-1824 and 922-0557

661-0981 Shield Kit (EMI shielding)

922-1825 PCBA Front Panel (front panel control board)

922-1826 Speaker Assembly (speaker and wire)

922-0117 Screw

076-0489 Chassis Kit (bare chassis)

922-0503 FoxConn Cable Assembly (logic board connector and cable assembly)





Service Parts Now Available for Chassis 661-1094

661-0981 Shield Kit (EMI shielding)

922-1825 PCBA Front Panel (front panel control board)

922-1826 Speaker Assembly (speaker and wire)

922-0117 Screw





Chassis Harness Take Apart Procedures

First remove the chassis harness assembly.

EMI Shields

- 1 Remove the EMI shields in this order: lower shield, front drive and speaker shield, top panel shield.
- 2 Remove the front panel control board shield if it is present.





Speaker Assembly

First remove the EMI shields.

Caution: The speaker wire connections on the chassis cable bridge are very fragile. Avoid removing or replacing the speaker wires unless you need to replace the chassis or have isolated the problem to the speaker wires. (That is, replace and test the speakers, front panel control board, and analog board first.)

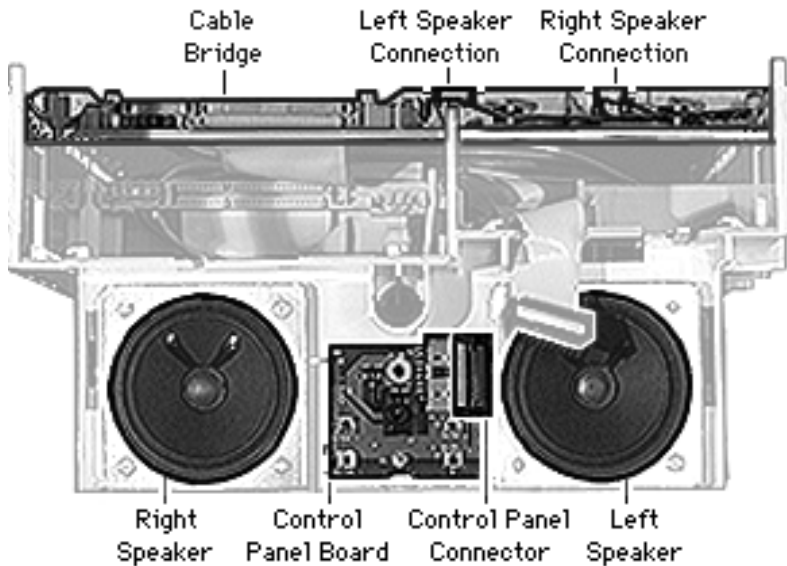



- 1 Disconnect the speaker wire spade connector from the back of the speaker.
- 2 Remove the Phillips screws from the front of the speaker.

Replacement Note: Detach the replacement speaker from its wires and connect the replacement speaker to the original speaker wires.

Speaker Wires

Note: The speaker wire connectors are very fragile.

- 1 Look down on the chassis cable bridge and locate the notches in the cable bridge on top of the wire connectors.
- 2 Using a jeweler's screwdriver, very gently press down on the tab in the middle of the wire connector. You will feel or hear a snap.





- 3 Slide out the wire connector.

Replacement Note: The analog board slides into the computer and completes the connection to the speaker wires; thus, the speaker wire connectors must sit securely in the cable bridge.

- 4 Slide the speaker wire connector into its position in the cable bridge and press up until the connector is secure. You may need to use a jeweler's screw driver to adjust the small metal tab in the center of the speaker wire connector.





Front Panel Control Board

First remove the EMI shields.

- 1 Disconnect the front panel control cable.
- 2 Remove the Phillips screw and remove the board.

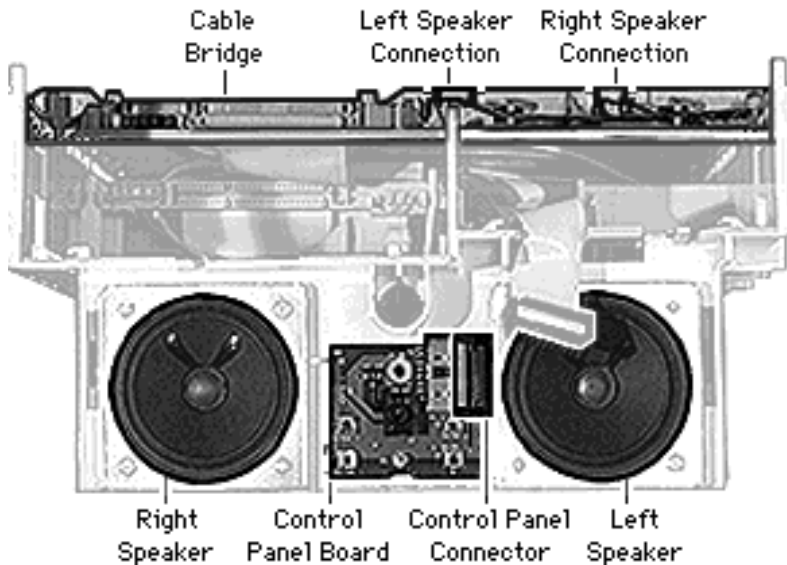



Logic Board Connector and Cable Assembly

First remove the EMI shields, speaker assembly, and front panel control board.

Overview of removal procedures (Detailed steps follow the overview.)

First disconnect all the connections from the top of the chassis. Then route the cables through to the underside of the chassis and disconnect the logic board connector.



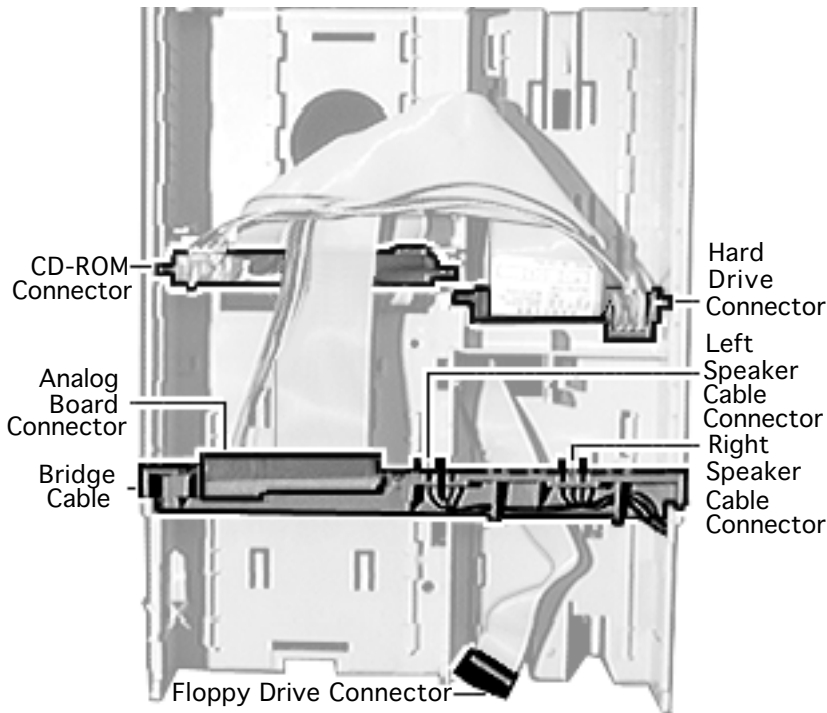

- 1 Stand at the front of the chassis, looking down at the top of the chassis, and disconnect the following in the order listed: analog board connector, CD-ROM drive connector, and hard drive connector. (The connector tabs operate much like large-scale SIMM slot connectors on logic boards.)





- 2 Route the analog board and the CD-ROM/hard drive cables through the large square hole behind the CD-ROM drive bay.
- 3 Push the floppy drive cable (if present) and front panel control cable to the underside of the chassis.
- 4 Turn the chassis over and stand at the rear of the chassis.
- 5 Release the three tabs from the sides and center of the logic board connector and remove the logic board connector and cable assembly.





Overview of replacement procedures (Detailed steps follow the overview.)

Connect the logic board connector to the underside of the chassis, route the cables through the appropriate openings, and connect the connectors on the top and front of the chassis. After replacing the logic board connector and cable assembly, replace the speakers, front panel control board, and EMI shields.

- 1 Place the chassis with the underside facing up and the speakers facing away from you.



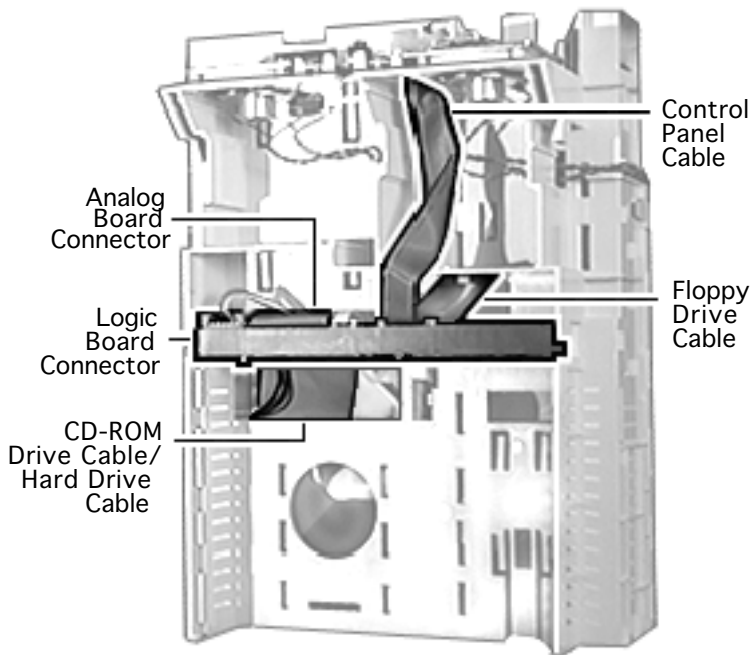

- 2 Arrange the logic board connector and cable assembly as shown.
- 3 Face the connector slot of the logic board connector toward the rear and from the back of the connector route the CD-ROM/hard drive, analog, and floppy drive cables under the connector. Extend the control panel connector cable from the back of the logic board connector toward the front of the chassis.



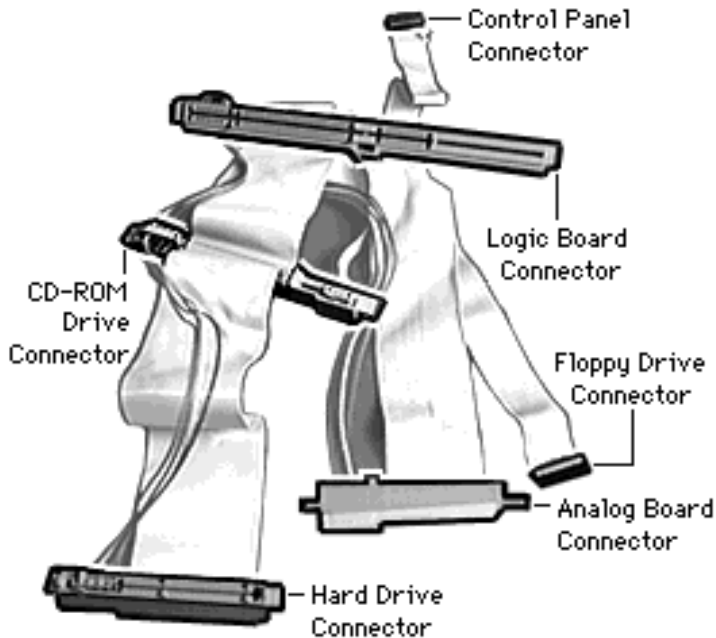

Logic Board Connector and Cable Assembly

- 1 Slide the side extension of the logic board connector down the front side of the small keyed tabs. The logic board connector will snap into place.

Note: Be sure the center tab snaps into place at the same time.

- 2 Route the front panel control cable through the hole in the front of the chassis





- 3 Route the floppy drive cable through its opening at the back of the floppy drive bay.
- 4 Carefully route the analog and CD-ROM/hard drive cables through the large opening behind the CD-ROM drive bay
- 5 Turn over the chassis so that the top is up and the speakers are at the front, facing you.

Important: Be sure to reconnect the CD-ROM, hard drive, and analog connectors in the proper order. When you position the CD-ROM, hard drive, and analog connectors, be sure that the power cables are placed toward the outside of the chassis and the data ribbon cables are placed toward the inside of the chassis.

- 6 Locate the CD-ROM, hard drive, and analog connectors.
- 7 Position the CD-ROM connector with the connector slot





facing the front of the chassis and the power cables facing toward the outside edge of the chassis. Slip the connector extension through the slot in the side of the chassis and slide the connector into place.

- 8 Position the hard drive connector with the connector slot facing the rear of the chassis and the power cables facing toward the outside edge of the chassis. Slip the connector extension through the slot in the side of the chassis and slide the connector into place.
- 9 Position the analog board connector with the connector slot facing the rear and the power cables facing toward the outside edge of the chassis. You will have to route the cable under the connector (between the connector and the cable bridge). Slightly push forward one of the keyed tabs and slide the connector into place.





- 10 To replace the speakers, front control panel board, and EMI shields, reverse the take-apart procedures above. Pay attention to the caution regarding the fragility of the speaker wire connectors and their replacement procedures.



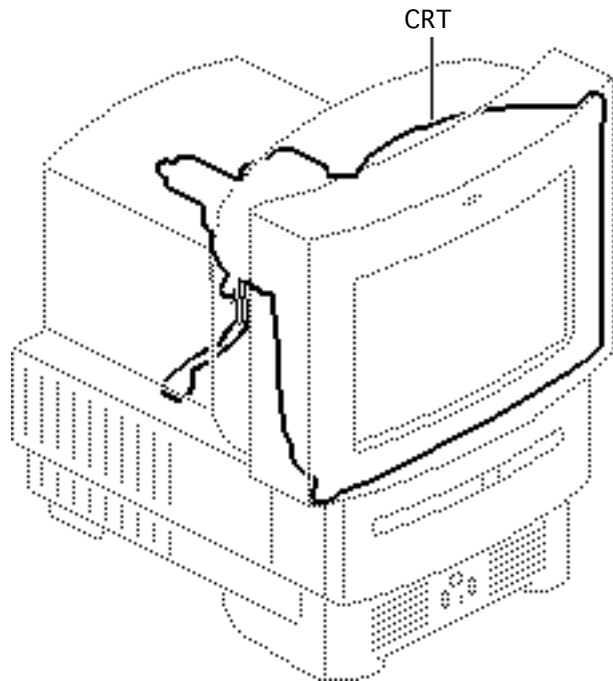

CRT

⚠ Warning: This product contains high voltage and a high-vacuum picture tube. To prevent serious injury, review CRT safety in Bulletins/Safety.

Before you begin, remove the following:

- Drive bezel
- I/O door
- CD-ROM drive
- Floppy drive
- Hard drive
- Logic board
- Rear housing



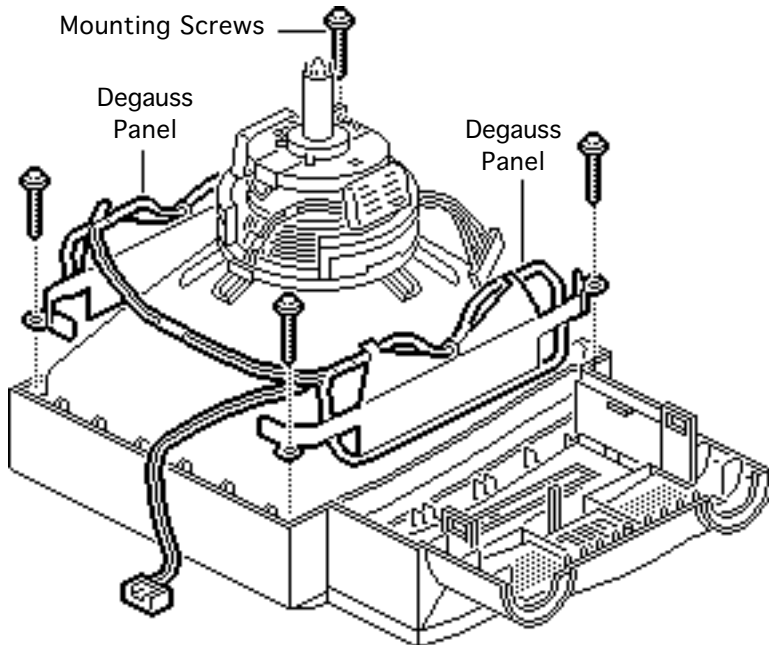

- Analog board
- Chassis harness assembly

⚠ Warning: Never use a grounding wriststrap until after discharging the CRT.

- 1 Remove the four mounting screws and lift off the two degauss panels.



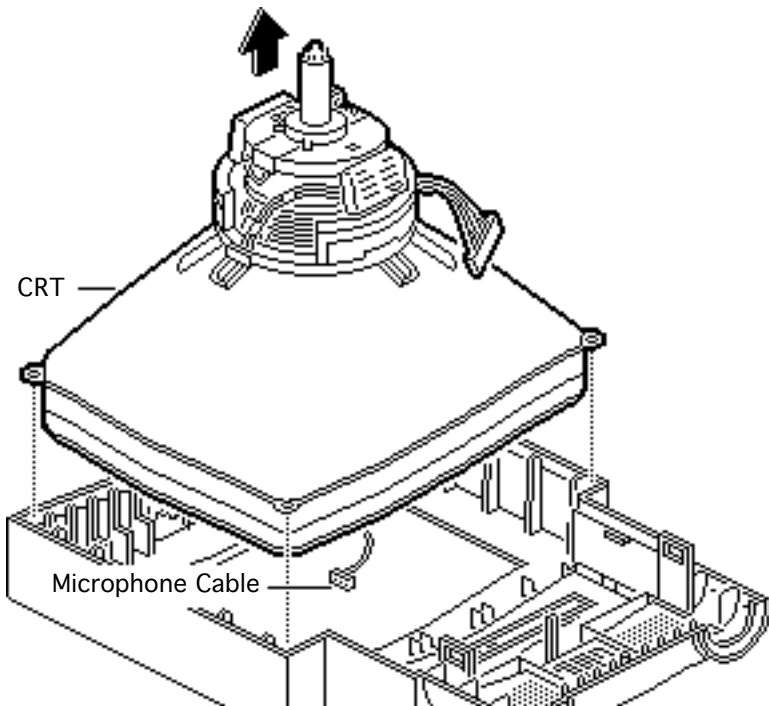

2 Lift off the CRT.

Replacement Note: Be sure the microphone cable is not caught under the CRT.





Internal Microphone

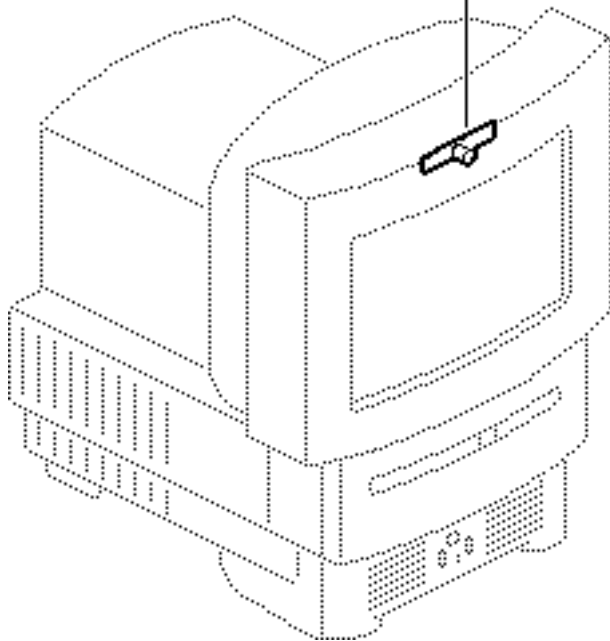

Internal Microphone

Before you begin, remove the following:

- Drive bezel
- I/O door
- CD-ROM drive
- Floppy drive
- Hard drive
- Logic board
- Rear housing
- Analog board
- Chassis harness assembly
- CRT



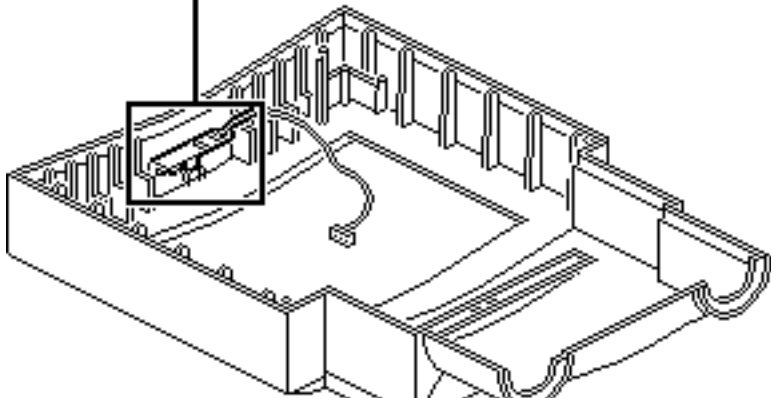
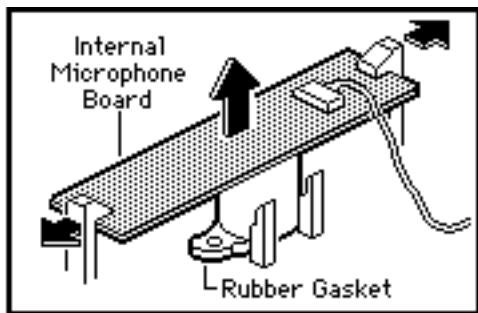

⚠ Warning: This product contains high voltage and a high-vacuum picture tube. To prevent serious injury, review CRT safety in Bulletins/Safety.

⚠ Warning: Never use a grounding wriststrap until after discharging the CRT.

- 1 Push out the two latches and remove the internal microphone board and the rubber microphone gasket.





Replacement Note: Be sure the rubber gasket is in place before replacing the microphone board.



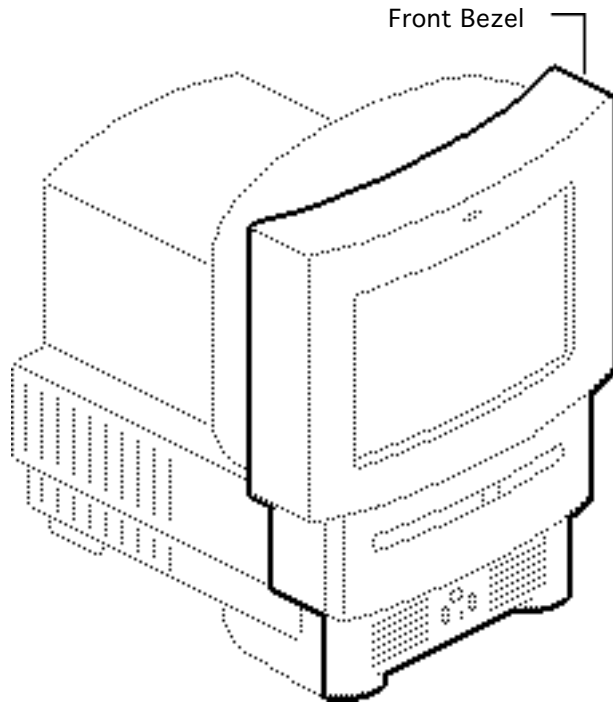

Front Bezel

To remove the front bezel, remove the following:

- Drive bezel
- I/O door
- CD-ROM drive
- Floppy drive
- Hard drive
- Logic board
- Rear housing
- Analog board
- Chassis harness assembly
- CRT
- Internal microphone



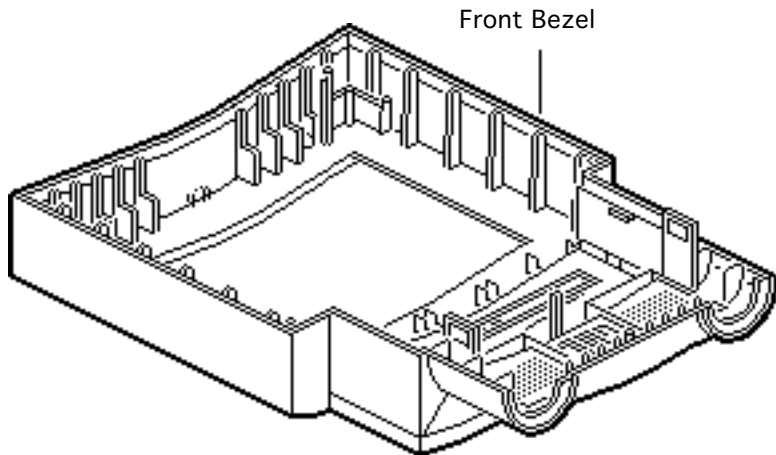

⚠ Warning: This product contains high voltage and a high-vacuum picture tube. To prevent serious injury, review CRT safety in Bulletins/Safety.

⚠ Warning: This product contains high voltage and a high-vacuum picture tube. Never use a grounding wriststrap until after discharging the CRT. Review CRT safety in Bulletins/Safety.





Upgrades

Performa 500 Series





Macintosh Processor Upgrade

Before you begin, remove the following:

- I/O door
- Logic board
- Card in PDS slot (if any)

Caution: Review the ESD precautions in Bulletins/ Safety.

Note: The Macintosh Processor Upgrade kit allows 68LC040 computers to switch between a PowerPC 601 processor

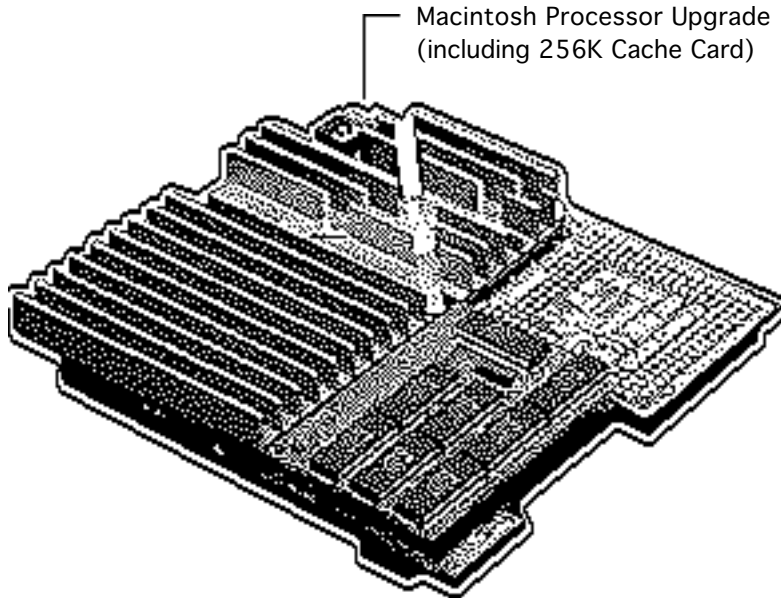



and a 68LC040 processor. The upgrade board includes the PowerPC 601 processor on board and a socket to accept the customer's 68LC040 processor.

Note: The Macintosh Processor Upgrade for the Performa 520, 550, and 560 consists of a Macintosh LC 575 logic board, the Macintosh Processor Upgrade Card, a new rear panel, and the 575 product ID label.

To install this upgrade,





follow the Macintosh LC 575 Macintosh Processor Upgrade procedures in this topic, substituting the 575 logic board, rear panel, and ID label for those installed on the Performa 550, or 560.

Note: Refer to the Macintosh Processor Upgrade manual for information about specifications and troubleshooting.

Note: The Macintosh Processor Upgrade comes packaged with the Macintosh



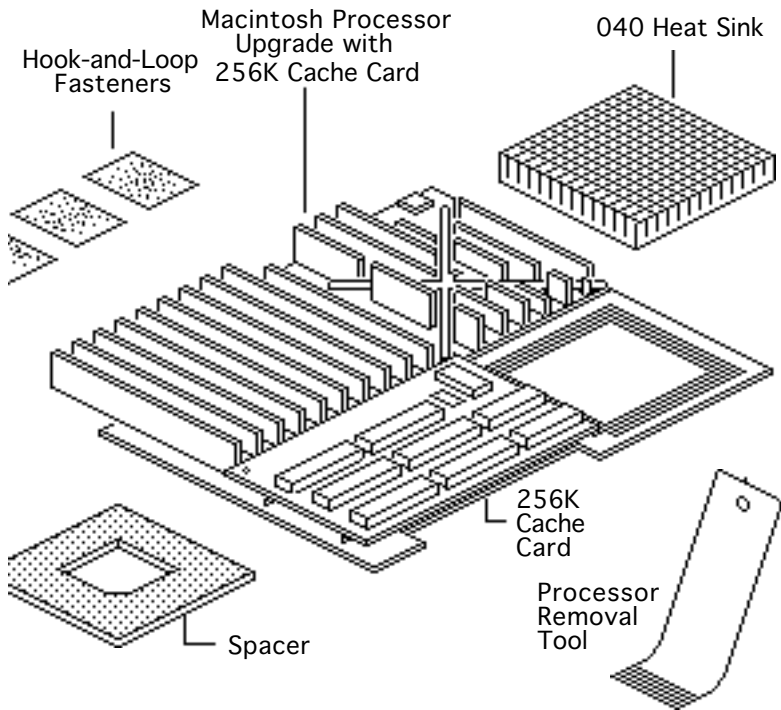

Processor Upgrade board, 256K cache card, 040 heat sink, and hook-and-loop fasteners. If you need to order service replacement parts, order the parts separately.

Note: To install the upgrade, you will need a processor removal tool. Order the removal tool as a separate service part.

Note: The cache card comes installed on the upgrade board.





Installation Procedure Overview

There are four basic steps to installing the Macintosh Processor Upgrade.

- Remove the 68LC040 processor from the customer's logic board
- Install the 68LC040 processor on the upgrade board
- Install the upgrade board on the logic board
- Reinstall the cache card on the upgrade board

Detailed procedures follow.





Remove the 68LC040 Processor from the Logic Board

- 1 Locate the 68LC040 processor on the logic board.

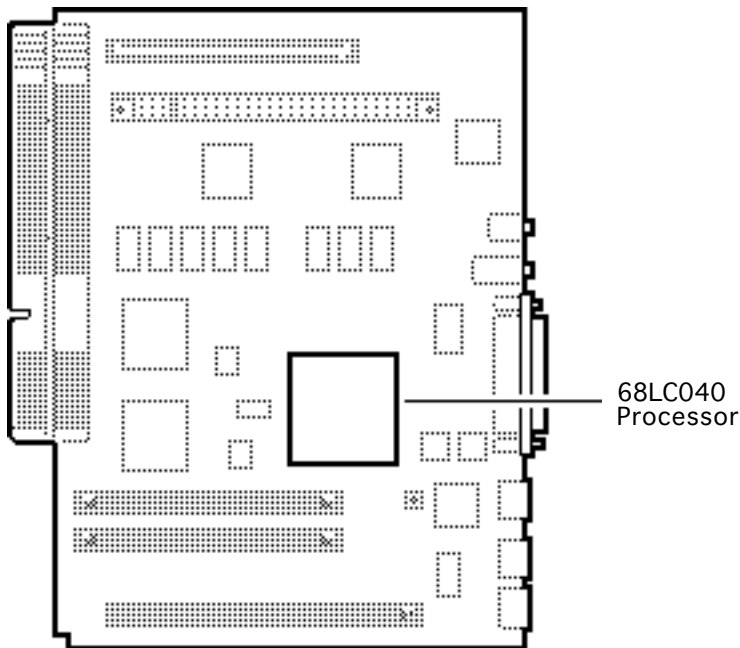

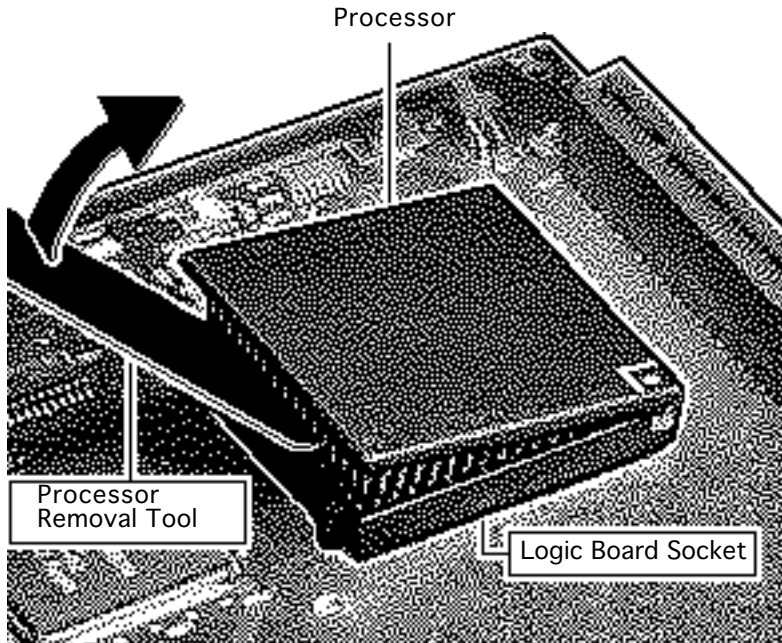

- 2 Position the teeth of the processor removal tool in the groove between the processor and the logic board socket.

Caution: Be sure to lift up on the handle of the processor removal tool. Pressing down could damage components on the logic board.

Note: This graphic shows the proper way to remove a 68LC040 chip from its logic board. Your logic board may differ somewhat.





- 3 **Caution:** Pry up each side of the processor only slightly to avoid bending the pins.

Gently lift up the processor removal tool handle and pry up each side of the processor from the socket.

- 4 Remove the processor.





Install the 68LC040 Processor on the Upgrade Board

Caution: Do not force the connector pins into the socket. Check pins to be sure none are bent.

Note: The alignment corner of the 68LC040 processor is missing one pin. The alignment corner of the upgrade socket is missing a pin hole.

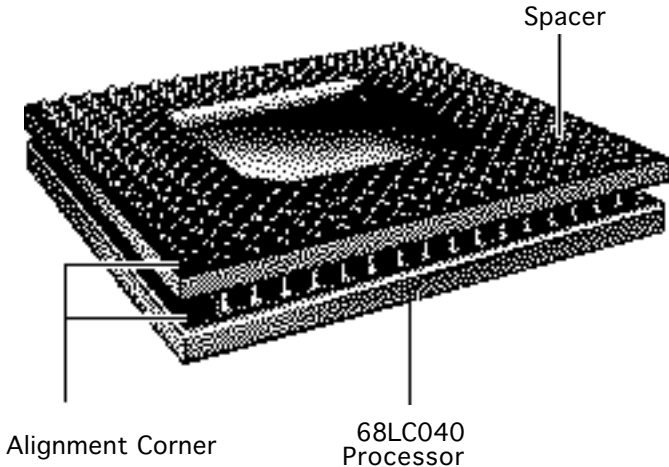



- 1 Position the 68LC040 connector alignment corner over the alignment corner of the upgrade board processor socket.
- 2 Carefully align the 68LC040 connector pins with the corresponding holes in the upgrade socket.



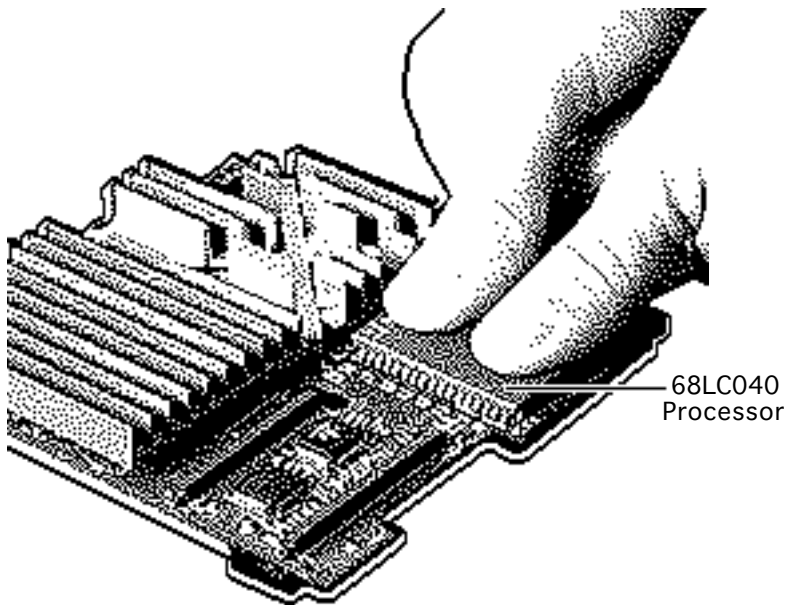

Caution: Forcing the 68LC040 processor connector pins into the socket could damage the pins. If the processor resists installation, check the pin alignment.

Caution: Place the upgrade board on a firm even surface to avoid bending the upgrade board when pressing the processor into the socket.

Caution: Use two thumbs to evenly distribute the pressure as you press the processor into the socket.





- 3 Hold the processor and spacer together and position the spacer alignment corner over the upgrade socket alignment corner.
- 4 Press the processor connector pins into the socket until you hear a snap.





Note: On a correctly installed 040 processor, a very small gap separates the 040 chip from the metal spacer. A larger gap caused by the barrel sockets of the upgrade board separates the upgrade board and the spacer.

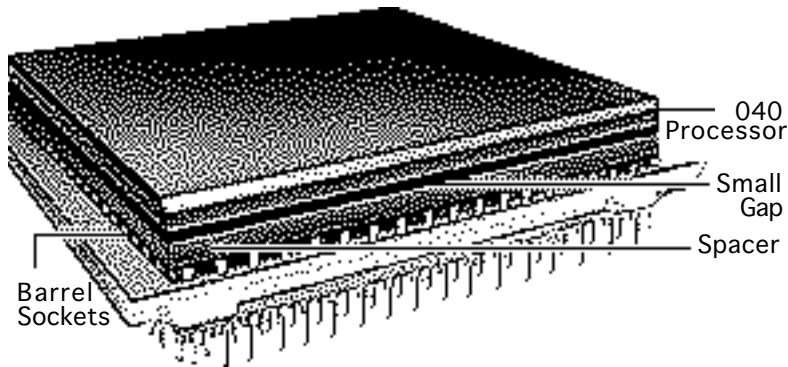

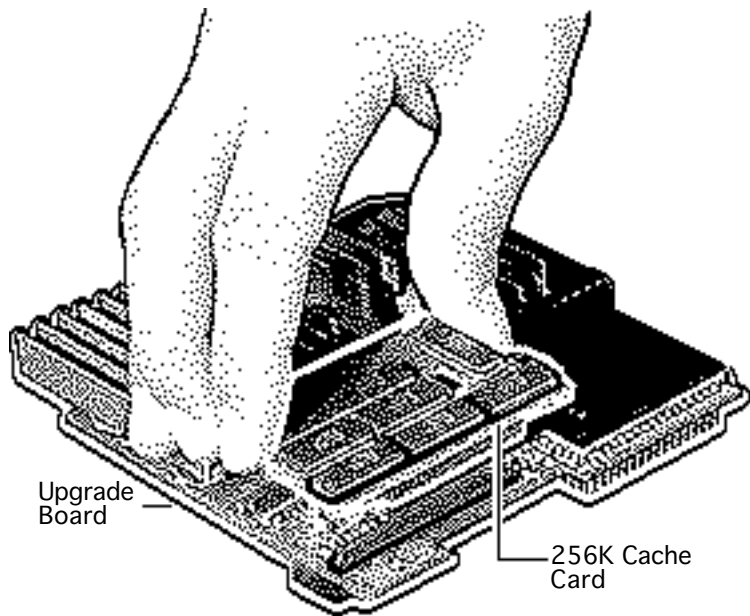

Prepare the Upgrade and Logic Boards for Installation

Note: The steps on this and the next page explain how to prepare the upgrade board to connect with the logic board.

- 1 Remove the 256K cache card from the upgrade board.

Note: You will re-install the cache card after the upgrade board connects to the logic board.



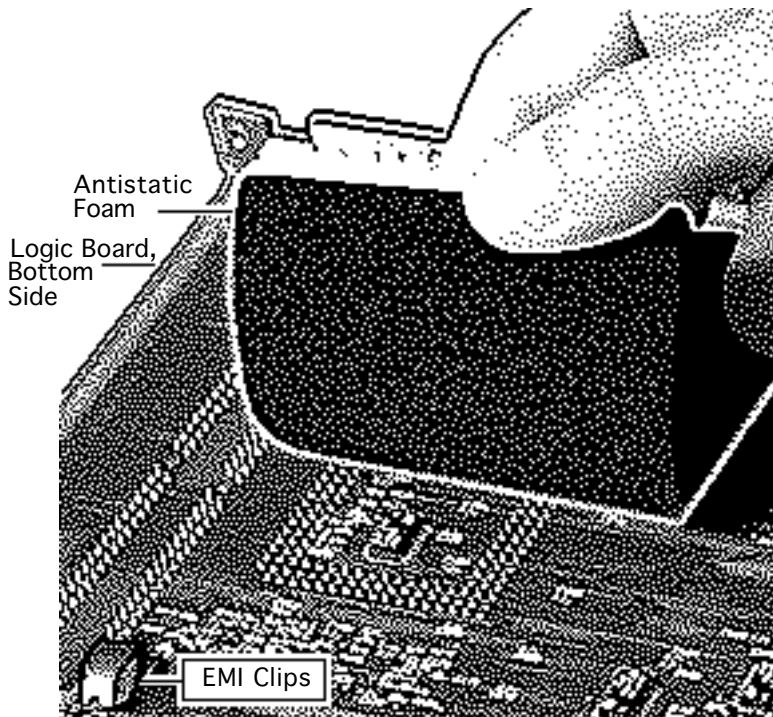

Caution: The EMI clips on the bottom of the LC 575 and Performa 570 series logic boards flex easily. Do not apply heavy pressure directly to these clips or you may bend the logic board.

- 2 Place a piece of antistatic foam directly under the processor socket on the bottom side of the logic board.
- 3 **Note:** This step helps prevent the logic board from bending when you apply pressure in the next few steps.





Peel the tape from the remaining sides of the two hook-and-loop fasteners. Afix the fastener in the position shown on the logic board.

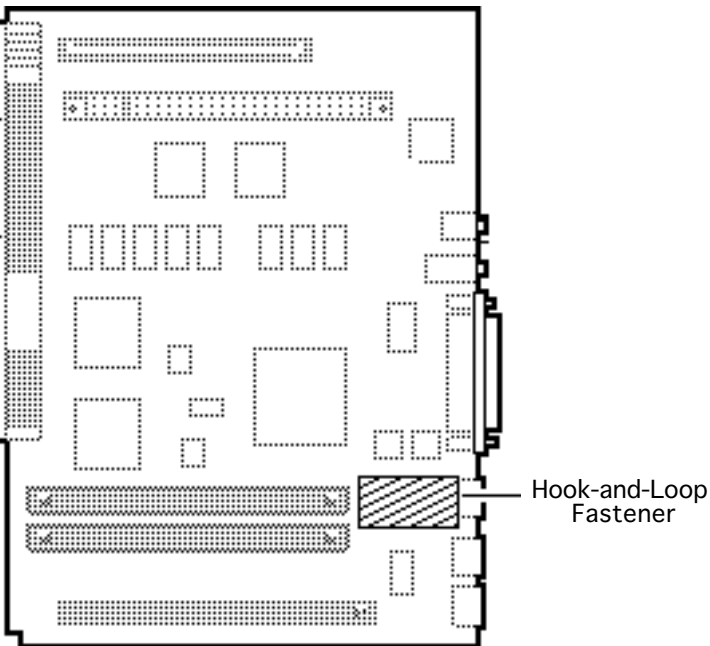

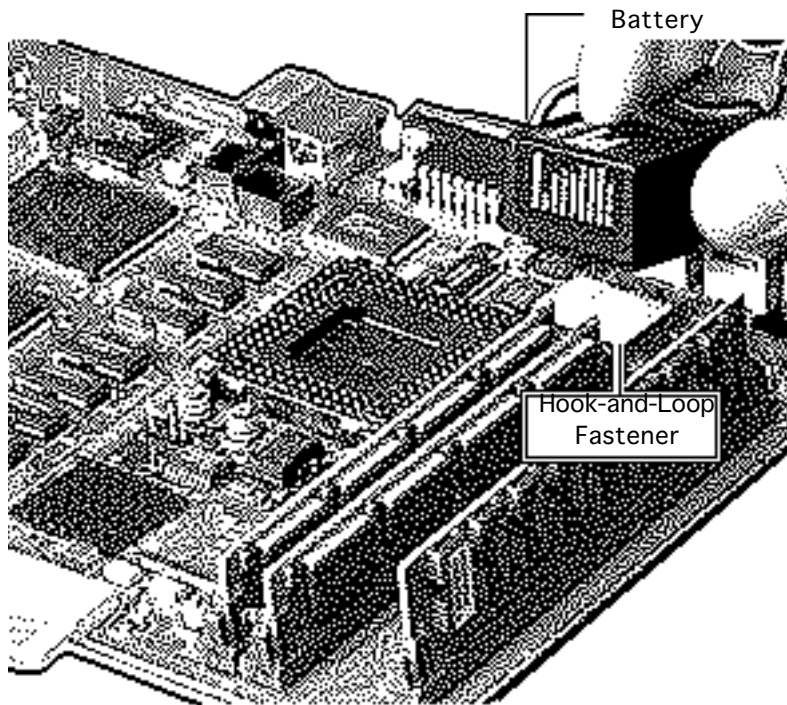

- 4 **Note:** This step makes room for the processor upgrade board.

Move the battery from its original hook-and-loop fastener to the fastener on the chip behind the ADB ports.



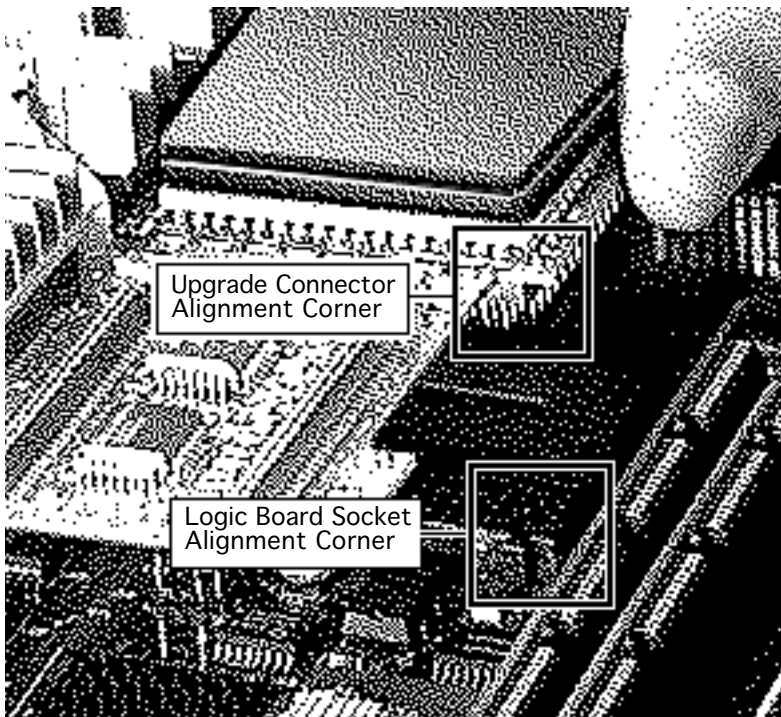

Install the Upgrade Board

Caution: Forcing the upgrade board connector pins into the logic board socket could damage the pins. If the connector resists installation, check the pin alignment.

- 1 Position the upgrade connector alignment corner over the logic board socket alignment corner.





PowerPC Heat Sink

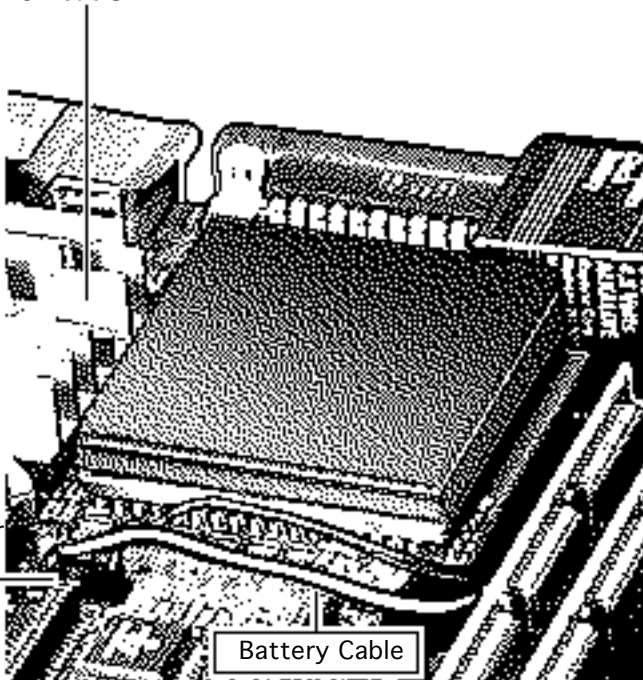

Hole
for
Battery
Connector

Battery Cable

- 2 Carefully align the pins along all sides of the processor and socket.
- 3 Firmly press the connector pins into the logic board socket.

Note: After you install the upgrade board, connect the battery cable through the hole in the upgrade board and reinstall the cache card.

- 4 Drop the battery connector through the hole in the upgrade board and connect the battery to the logic board.



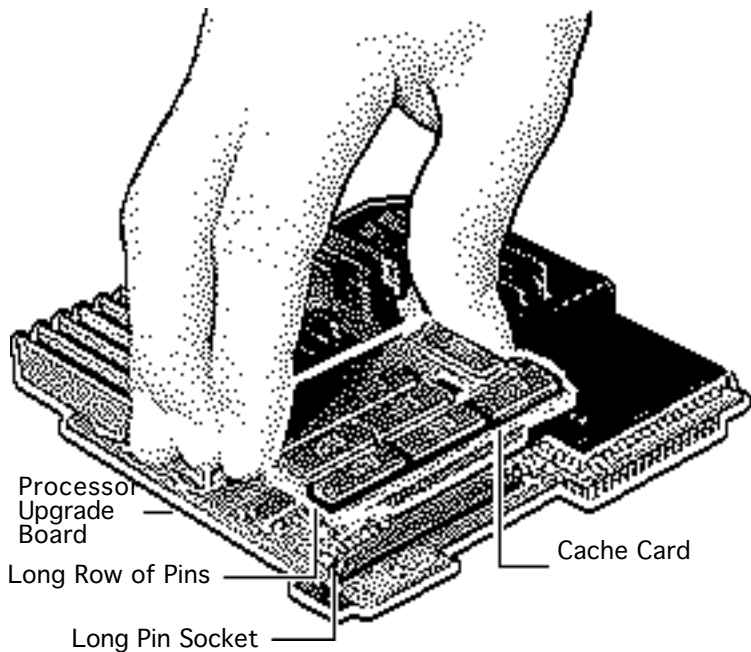

- 5 **Caution:** The heat of the heat sink can melt the battery cable.

Route the battery cable to avoid contact with the heat sink.

Note: There are two sockets on the cache card.

- 6 Align the longer cache card socket with the longer row of pins on the upgrade board.
- 7 Firmly press the cache card onto the upgrade board.





Note: To install the software, refer to the Upgrade Owner's Guide.





Logic Board and Upgrade Board Returns

Return the upgrade and logic boards to their original conditions before sending them to Apple. Be sure to remove the upgrade board from the logic board and reinstall the 68LC040 processor on the logic board.

Replacement Caution: To avoid bending any pins when removing the 68LC040 processor, pry up each side only slightly.





Additional Procedures

Performa 500 Series





Battery Verification

Before you begin, remove the following:

- I/O door
- Logic board

⚠ Warning: If handled or discarded improperly, the lithium battery in the computer could explode. Review battery handling and disposal instructions in Bulletins/Safety.

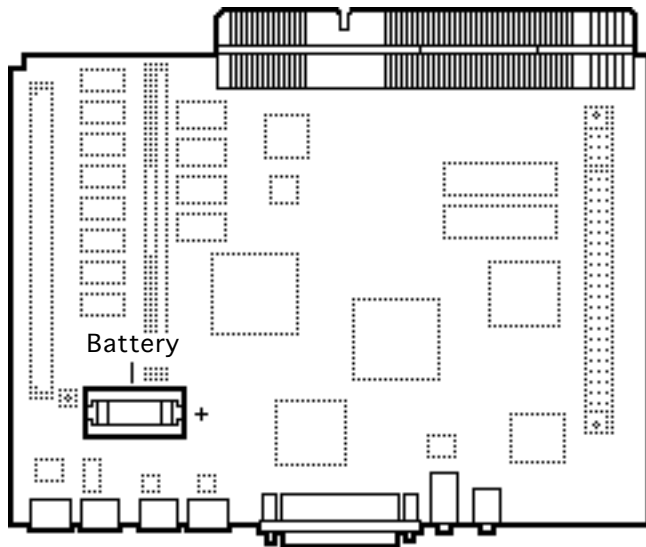

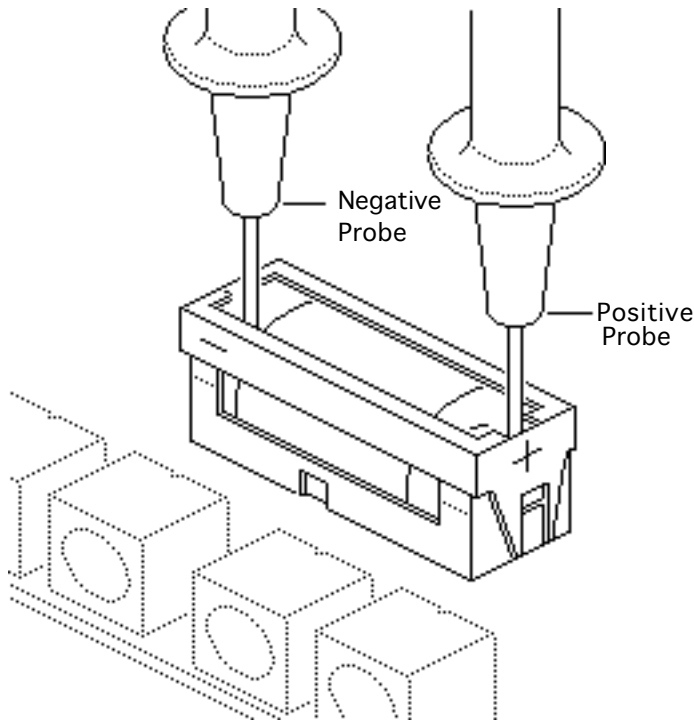

Caution: Review the ESD precautions in Bulletins/ Safety.

- 1 Set the voltmeter to the 10 volts DC scale.
- 2 Hold the positive probe of the voltmeter to the positive end of the battery and the negative probe to the negative end of the battery.
- 3 If the battery voltage is below 3.0 volts, replace the battery. Refer to “Battery Replacement” in this chapter.





Battery Replacement

Before you begin, remove the following:

- I/O door
- Logic board

⚠ Warning: If handled or discarded improperly, the lithium battery in the computer could explode. Review battery handling and disposal instructions in Bulletins/Safety.

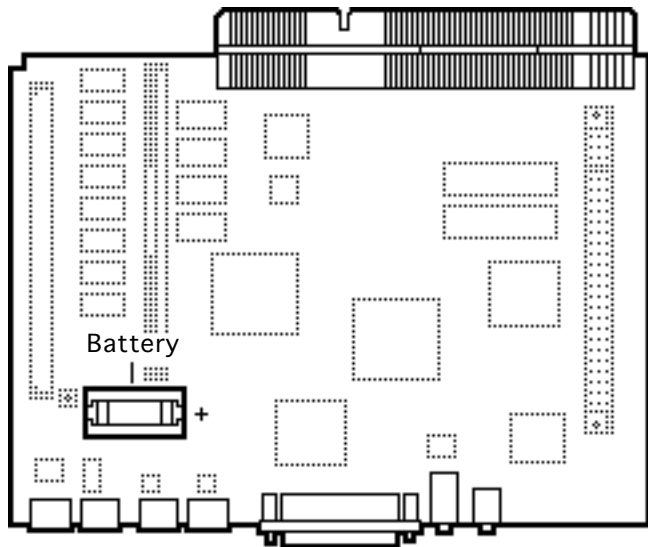

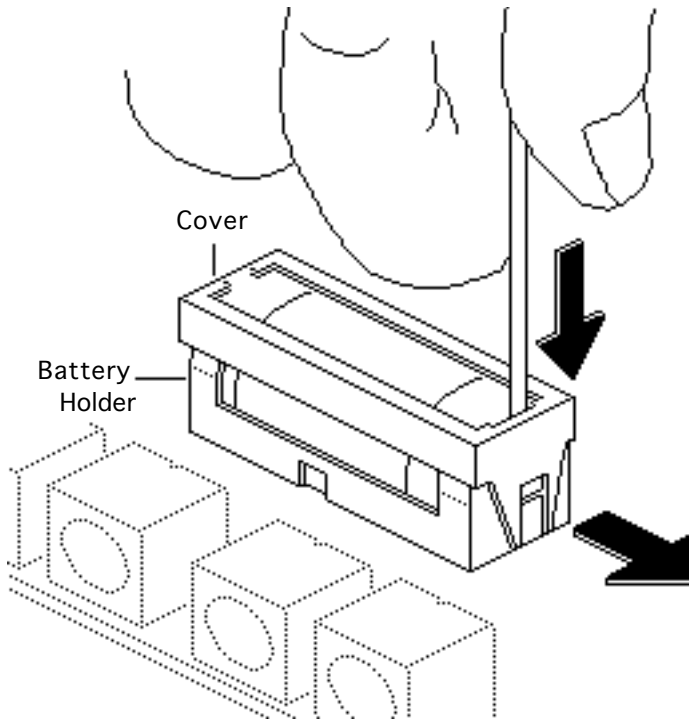

Caution: Review the ESD precautions in Bulletins/ Safety.

- 1 Insert a small flat-blade screwdriver into the top of the battery holder cover and gently push down and out with the screwdriver to release the tab.
- 2 Repeat on the other end and remove the cover from the battery holder.



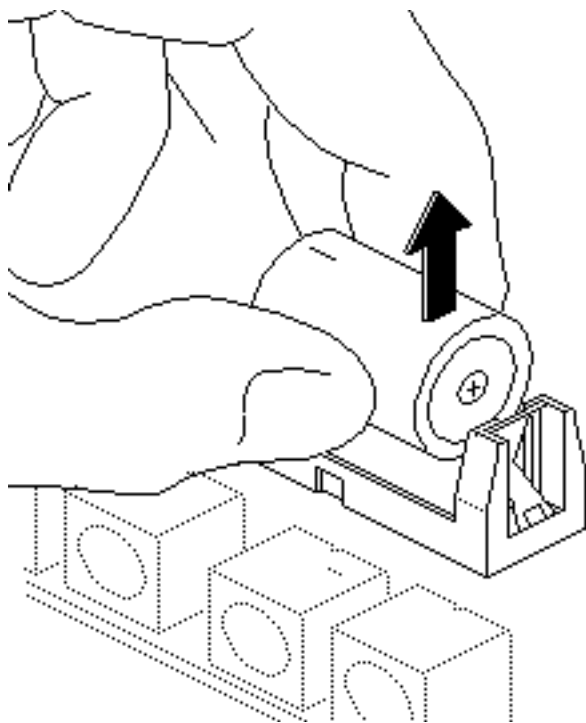

- 3 Grasp the battery and remove it from the holder.
- 4 Return the battery to Apple for proper disposal. For information on battery packaging and labeling, refer to the instructions in Bulletins/Safety.





Adjustments

Performa 500 Series





Geometry

Before you begin, remove the rear housing.

⚠ Warning: This product contains high voltage and a high-vacuum picture tube. To prevent serious injury, review CRT safety in Bulletins/Safety.

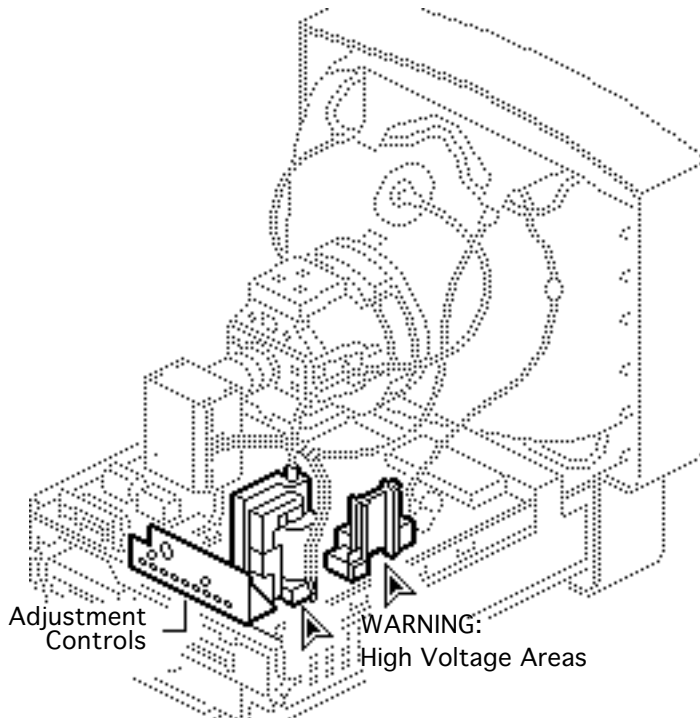



Note: The controls on this monitor require a small hex-head plastic tool to make adjustments. If the tool is long, it will be too flexible, which will make fine adjustments difficult. Use a short hex-head plastic tool to minimize flexing.

⚠ Warning: Do not use metal alignment tools—they are a shock hazard.



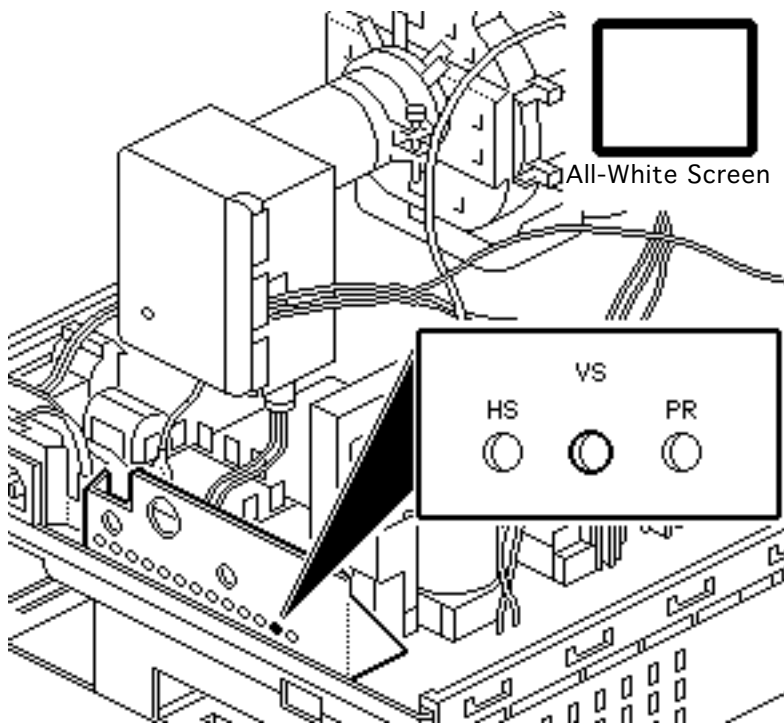

Vertical Center

- 1 Use Display Service Utility to display the All-White Screen test pattern.
- 2 Using a hex-head plastic adjustment tool, adjust the vertical center (VS) control until the raster is centered (top to bottom) in the display area.



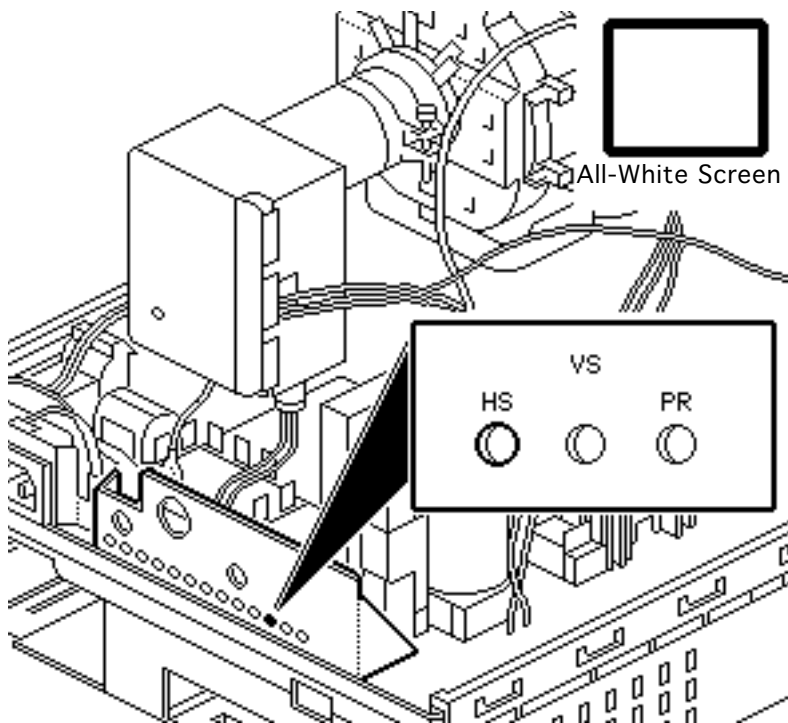

Horizontal Center

Using a hex-head plastic adjustment tool, adjust the horizontal center (HS) control until the raster is centered (side to side) in the display area.



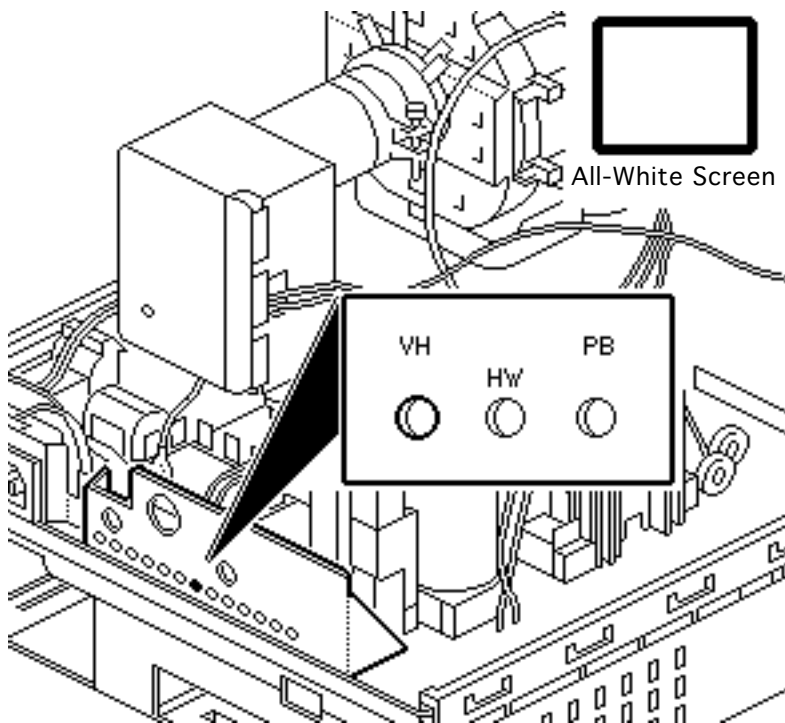

Vertical Size

- 1 Using a hex-head plastic adjustment tool, adjust the vertical height (VH) control until the raster height is 7 inches ($\pm 1/8$ inch) or 176 mm (± 2 mm).
- 2 Verify this height. If it is off, repeat the vertical size adjustment and, if necessary, the vertical center adjustment.



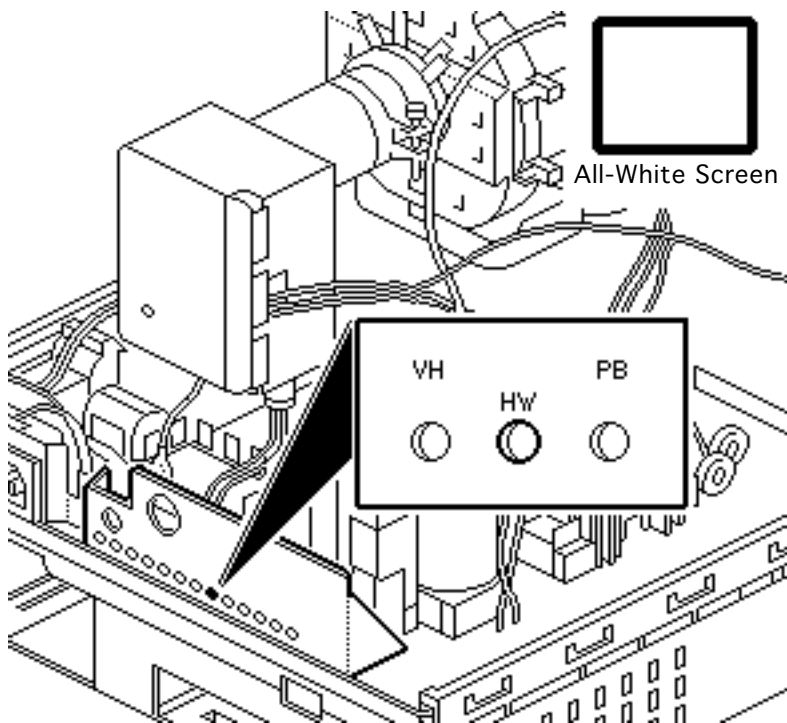

Horizontal Size

Note: Due to video features and timing differences across the Apple line of Macintosh computers, the width of the raster/image area on the Performa 550 screen may vary up to $3/16$ inch at each side of the screen. Perform the horizontal size adjustment to set the display to its proper width.





Using a hex-head plastic adjustment tool, adjust the horizontal width (HW) control until the raster is 9 1/4 inches ($\pm 1/8$ inch) or 235 mm (± 2 mm).



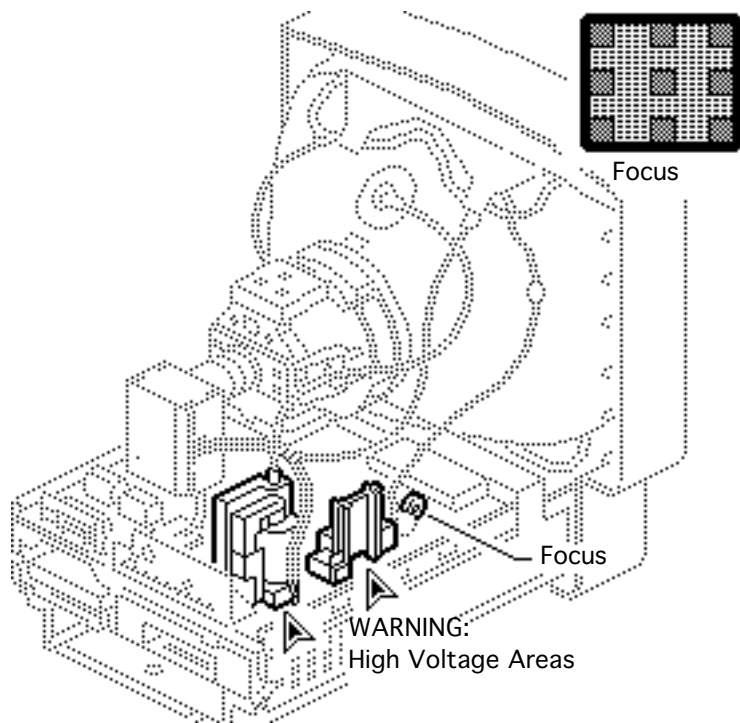

Focus

- 1 Use Display Service Utility to display the Focus test pattern.
- 2 Using a hex-head plastic adjustment tool, adjust the focus control until the Focus test pattern is as clear as possible.



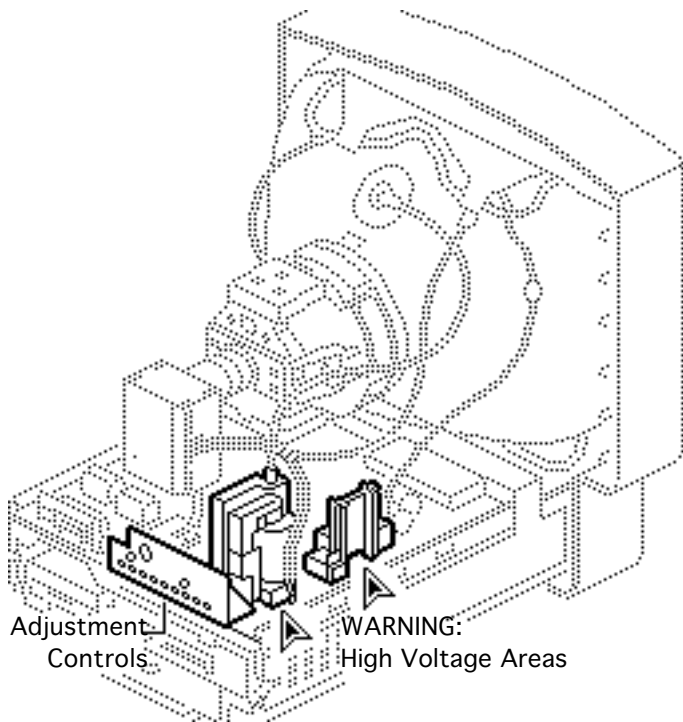

Video

Before you begin, remove the rear housing.

⚠ Warning: This product contains high voltage and a high-vacuum picture tube. To prevent serious injury, review CRT safety in Bulletins/Safety.

Note: Perform the cutoff adjustment prior to adjusting the white balance.





Replacement Note: Perform the cutoff adjustment whenever you replace the CRT or the analog board.



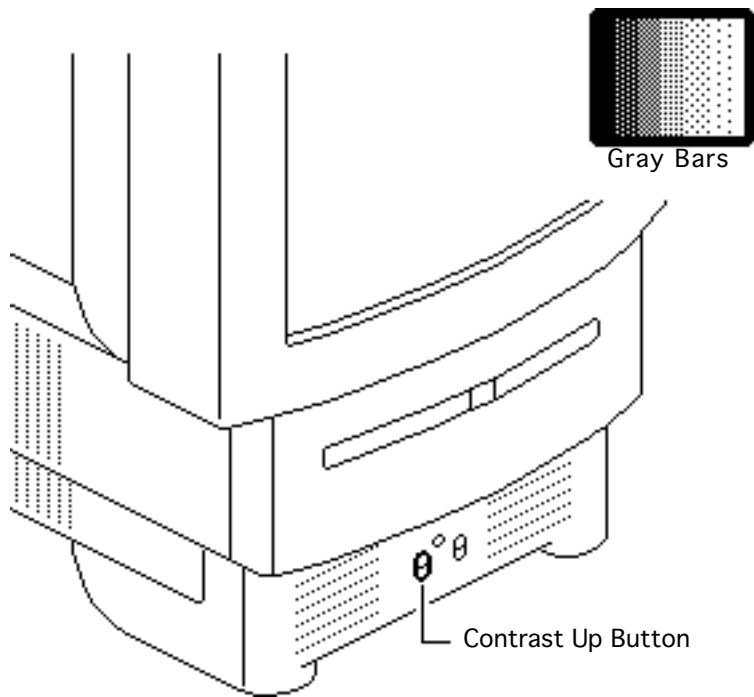

Cutoff

Note: Perform the cutoff and white balance adjustments after the monitor has been on for at least 10 minutes.

- 1 Use Display Service Utility to display the Gray Bars test pattern.
- 2 Press the Contrast Up button and set screen contrast to maximum.



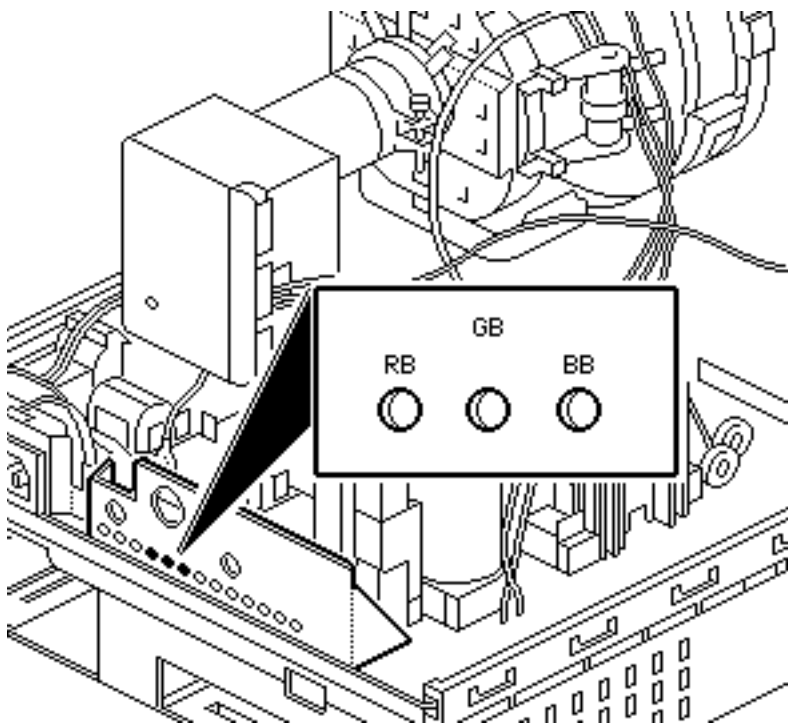

- 3 Select the Screen Control Panel in the Control Panels folder. Drag the brightness control to midrange.
- 4 Using a hex-head plastic adjustment tool, set the red (RB), green (GB), and blue (BB) background controls to the full counterclockwise positions.



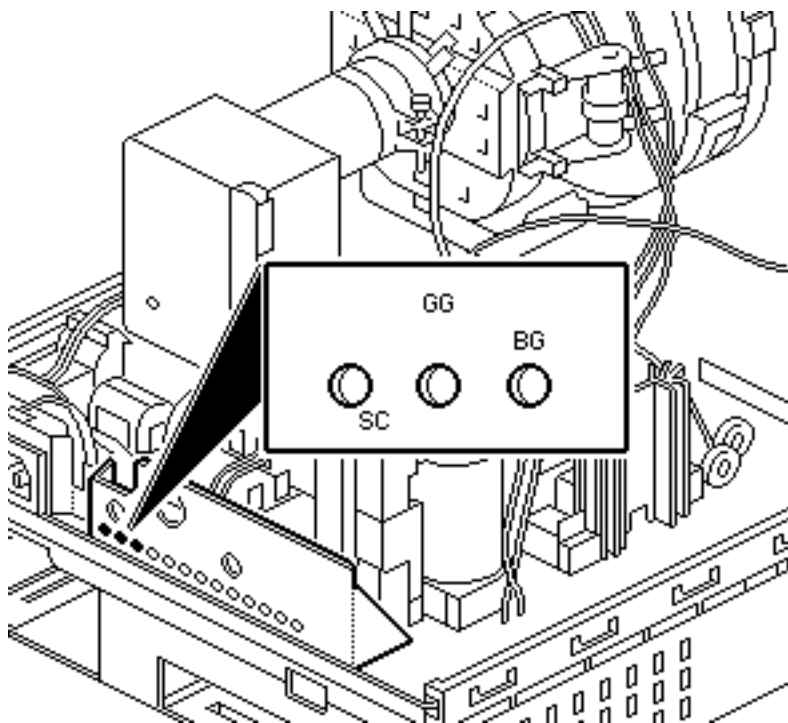

- 5 **Note:** To set the green and blue drive controls to their 3/4 position, turn the controls to their full clockwise position and then turn back 1/4 turn counterclockwise.

Set the green (GG) and blue (BG) drive controls clockwise to their 3/4 position.

- 6 Set the sub-contrast control (SC) to its full clockwise position.



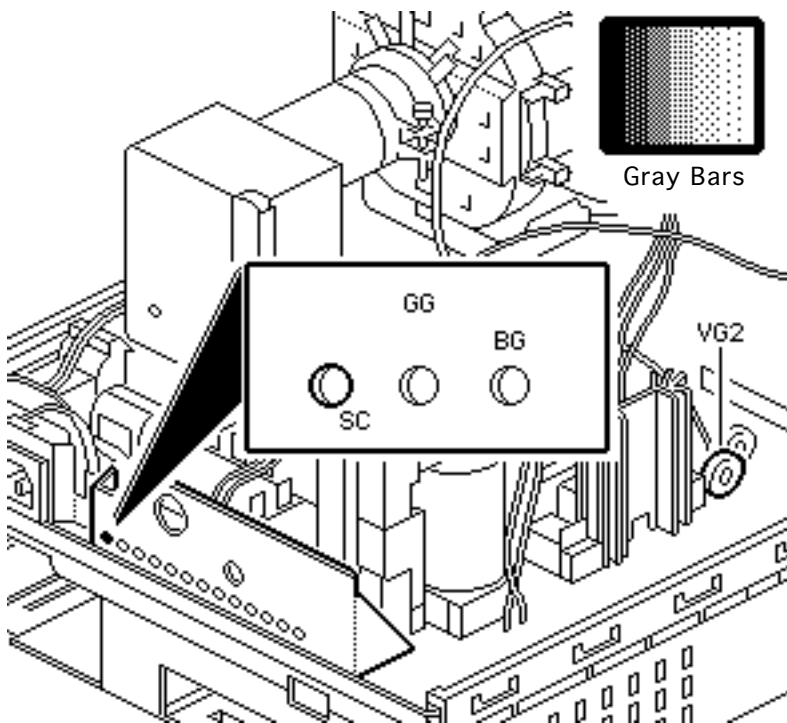

- 7 Using a hex-head plastic adjustment tool, adjust VG2 until the first bar in the test pattern is completely black and the second bar is barely visible.
- 8 Set the sub-contrast control (SC) to the center position.



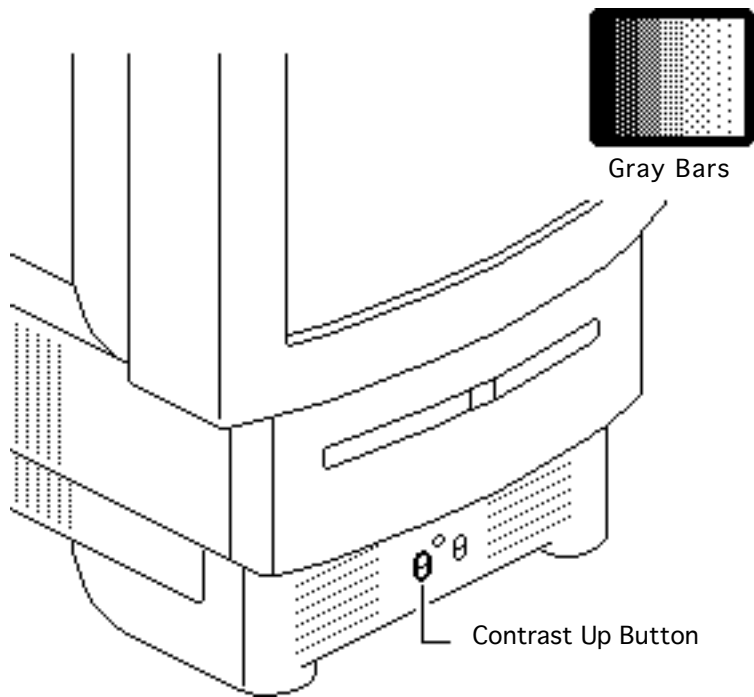

White Balance

Note: Perform the cutoff and white balance adjustments after the monitor has been on for at least 10 minutes.

- 1 Use Display Service Utility to display the Gray Bars test pattern.
- 2 Press the Contrast Up button and set screen contrast to maximum.



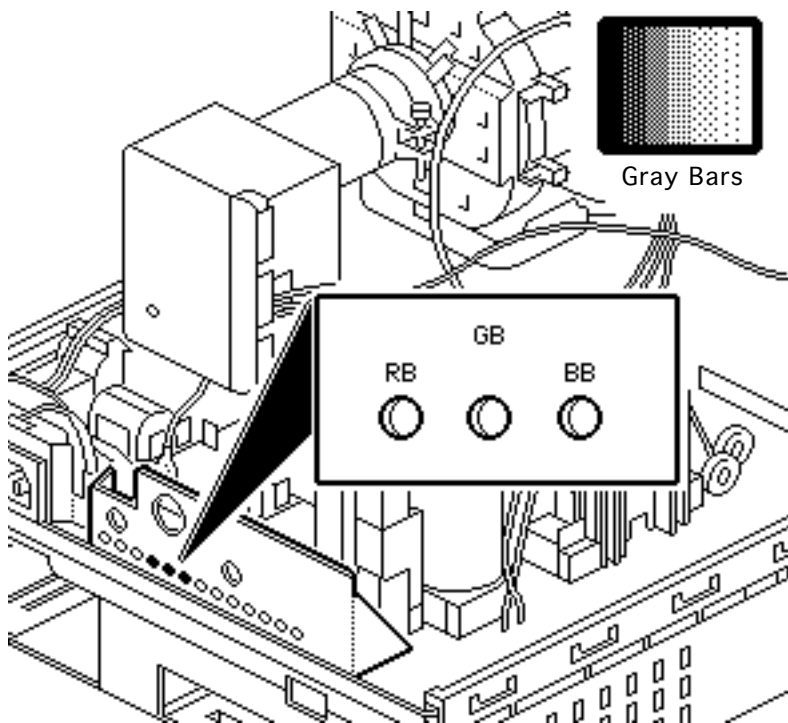

- 3 Select the Screen Control Panel in the Control Panels folder. Drag the brightness control to midrange.
- 4 Note the predominant color.
- 5 Using a hex-head plastic adjustment tool, alternately adjust the red (RB), green (GB), and blue (BB) background controls until there is no predominant color in the four darkest bars.



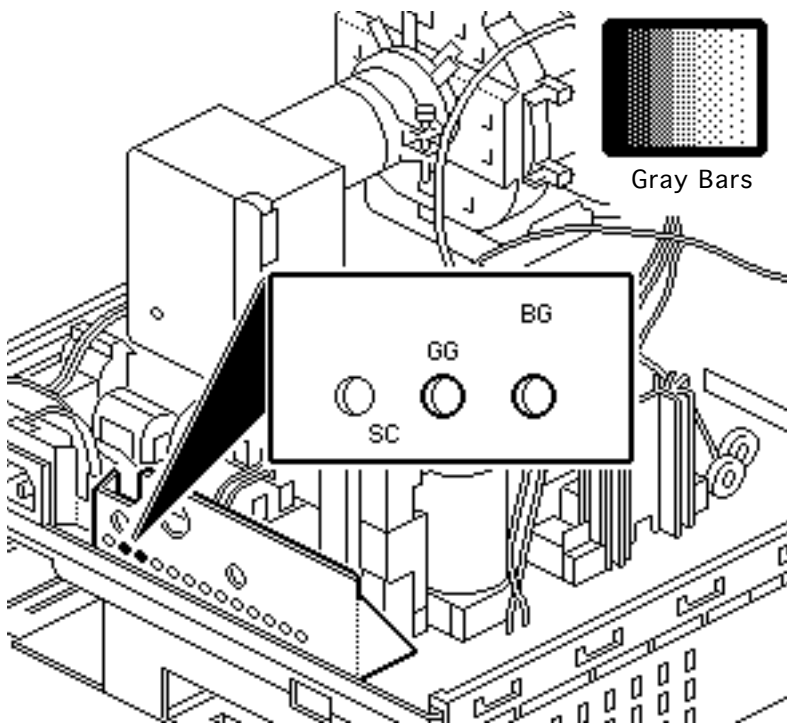

Note: The darkest bar must remain completely black throughout the rest of the procedure. If you notice a predominant color in the darkest bar, readjust the appropriate background control.

- 6 If necessary, adjust the blue (BG) and green (GG) drive controls until there is no predominant color in the four brightest bars.



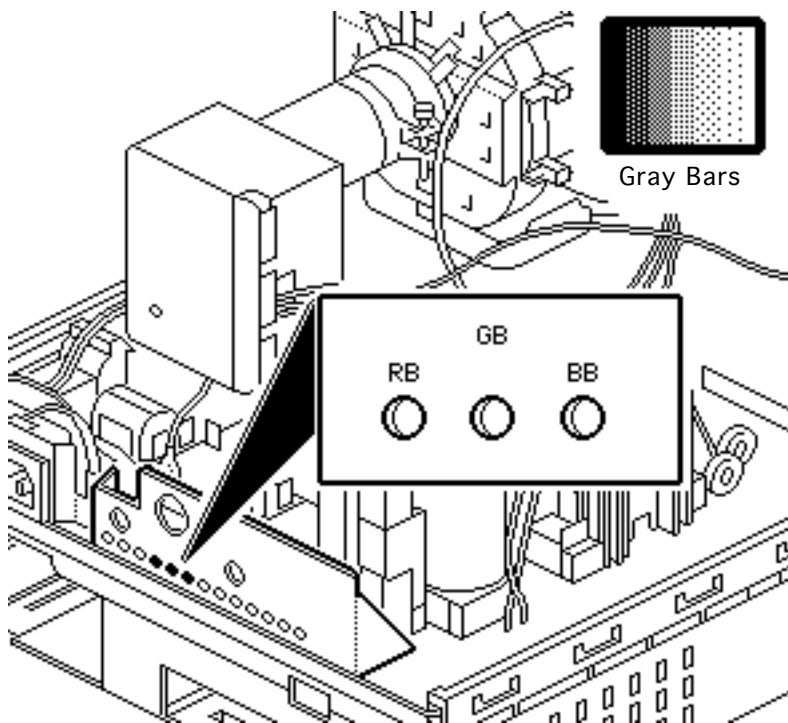

- 7 Check the four darkest bars, and if necessary, adjust the red (RB), green (GB), and blue (BB) background controls until there is no predominant color.



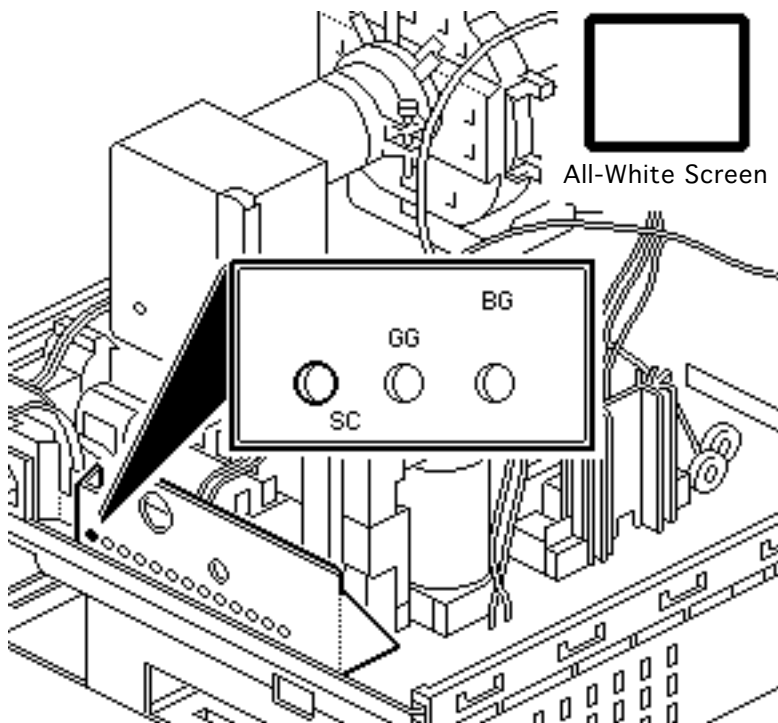

- 8 Use Display Service Utility to display the All-White Screen test pattern.
- 9 Using the light meter, adjust the sub-contrast control (SC) until the luminance measures 33 foot lamberts (± 3 foot lamberts), which on the light meter is
 - Model R77: 25 on the bottom scale
 - Model L-248: middle of the 10 scale
 - Model 246: 25 on the red scale





Important: Over time, light tolerances can vary. If you doubt your meter's accuracy, verify the readings with a known-good light meter or photometer.





Light Meter Setup

This topic covers setup for three light meter models: R77, L-248, and 246. Model R77 (Apple part number 076-0310) is the newest model available.

Model R77

The R77 light meter is capable of reading luminance from 10 to 1,000 footcandles (fc).

Before you begin, remove the 10X multiplier plate



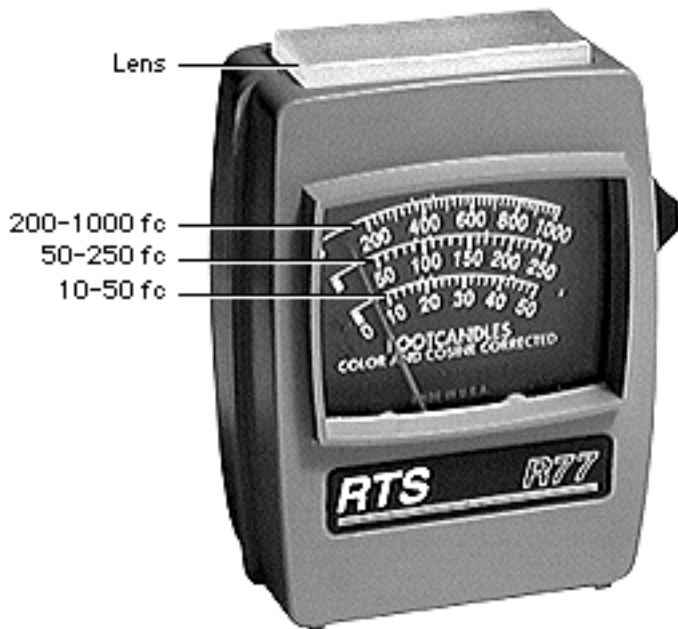

from the lens.

Three scales are shown on the light meter:

- 200-1000 fc
- 50-250 fc
- 10-50 fc

Because display screen luminance typically ranges from 10 to 50 fc, take readings from the bottom scale only.



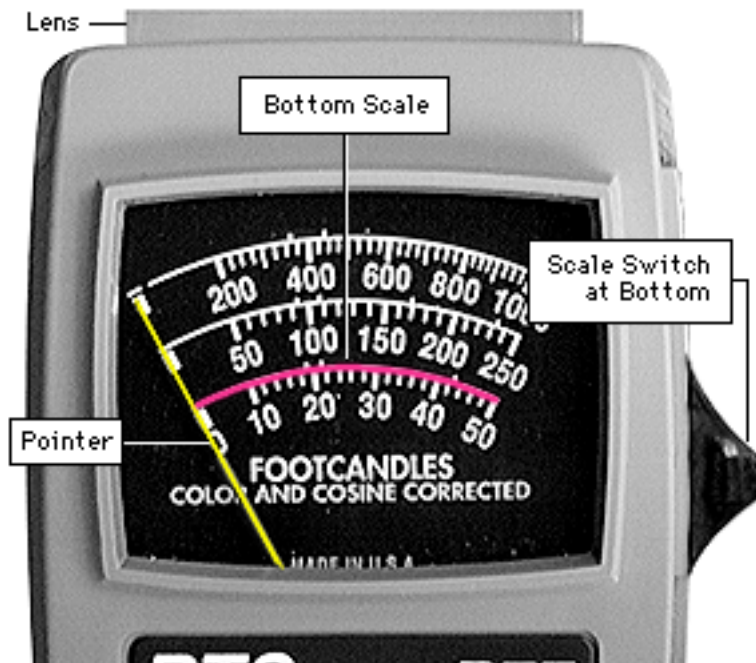

To measure a display screen's luminance,

- 1 Set the scale switch to the bottom position (to set up the 10-50 fc scale).
- 2 Place the lens against the middle of the screen and read the bottom scale.

Note: When the light meter is not in use, slide the scale switch to its top position, and store the meter in its protective case.

Important: If you suspect the light meter is giving false



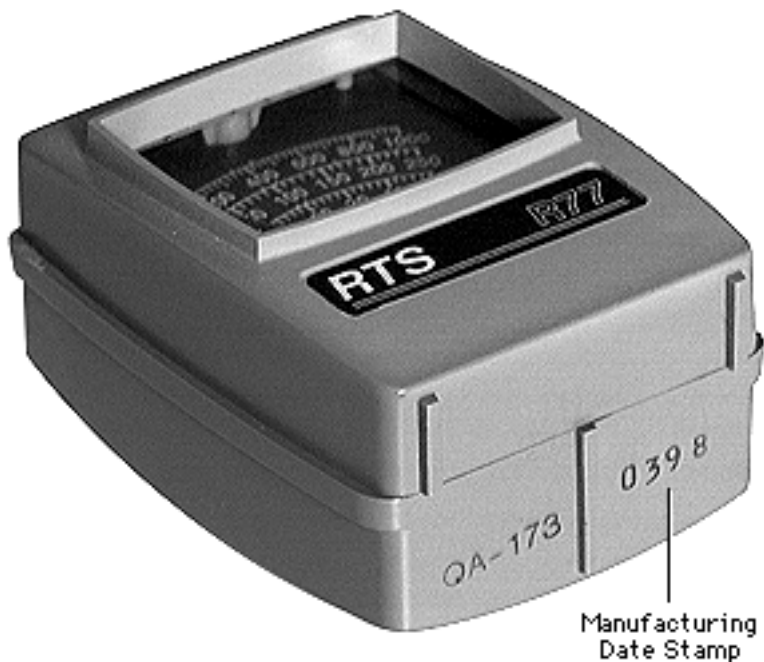

readings, verify the readings with a known-good light meter or photometer. Also check the age of the R77 light meter by its four-digit manufacturing date stamp (such as 0398 for March 1998).

Caution: Dropping the meter can permanently damage its accuracy. A shock-damaged meter might read incorrectly or its pointer may not drop to zero.



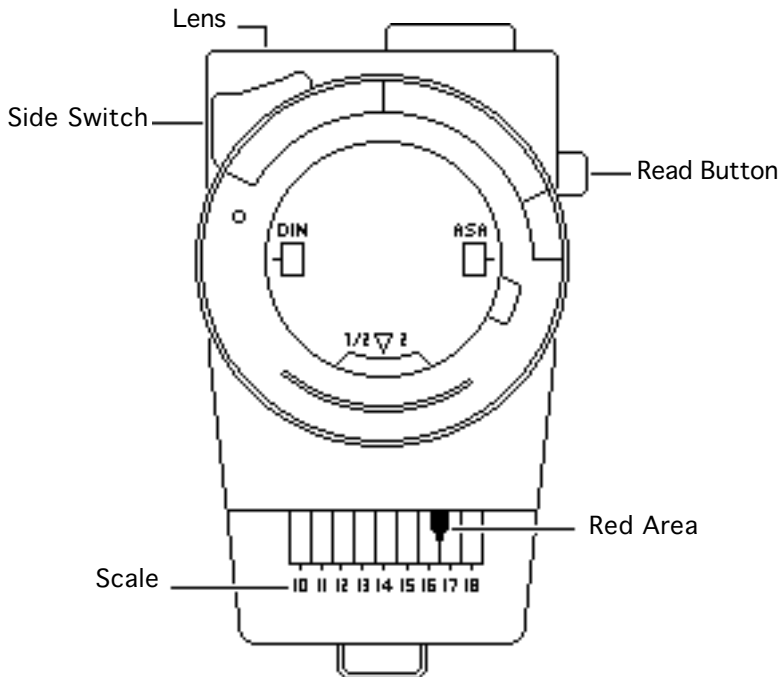

Model L-248

- 1 Press the red button on the back of the light meter. If the reading is out of the red area, replace the battery.
- 2 Move the side switch to its upper position so that the scale reads 10 through 18.
- 3 Uncover the lens of the meter.
- 4 Place the lens against the middle of the screen and press the read button to read the scale.



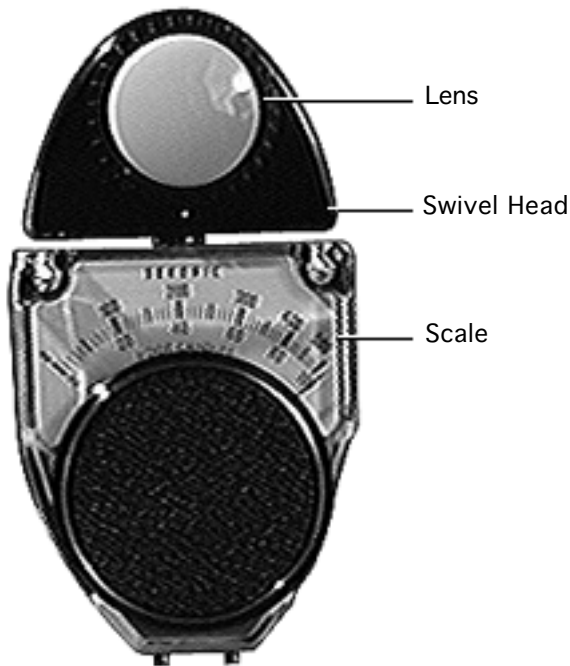

Model 246

- 1 Remove the metal slide, if installed, from the top of the light meter.
- 2 Install the white lens with the red dot.
- 3 Rotate the swivel head so the lens of the meter faces the monitor.
- 4 Place the lens against the middle of the screen and read the scale.





Convergence

Before you begin, remove the rear housing.

⚠ Warning: This product contains high voltage and a high-vacuum picture tube. To prevent serious injury, review CRT safety in Bulletins/Safety.

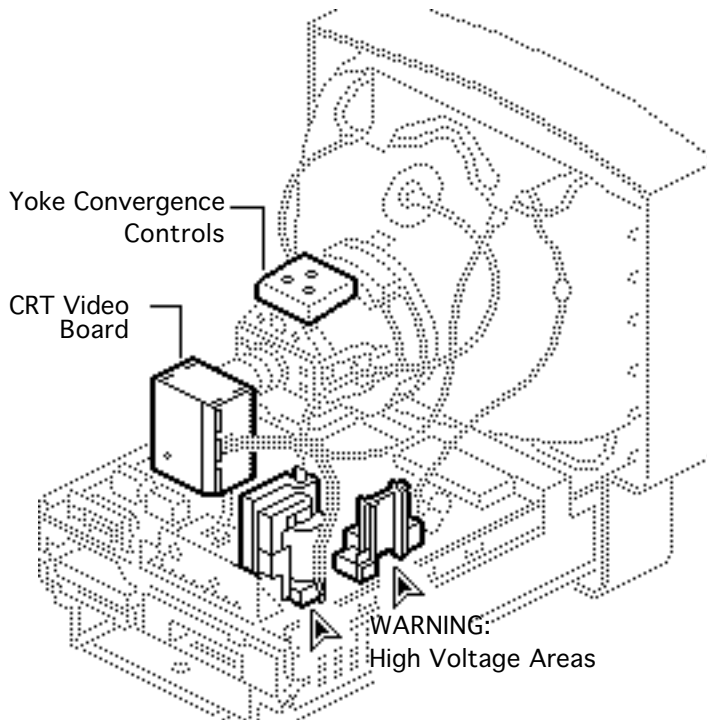

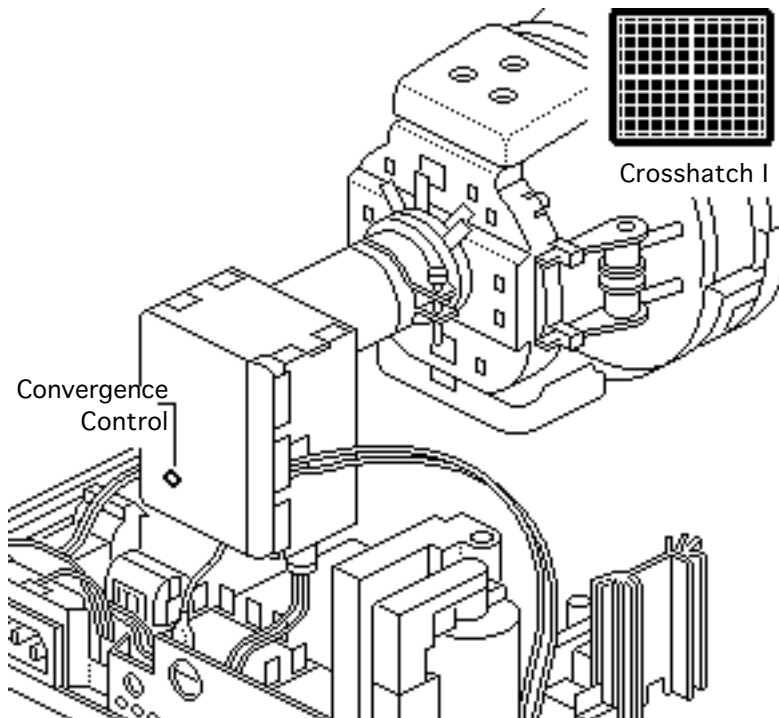

- 1 Use Display Service Utility to display the Crosshatch I test pattern.
- 2 Using a hex-head plastic adjustment tool, adjust the convergence control on the CRT video board for best overall convergence.



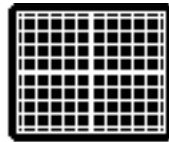
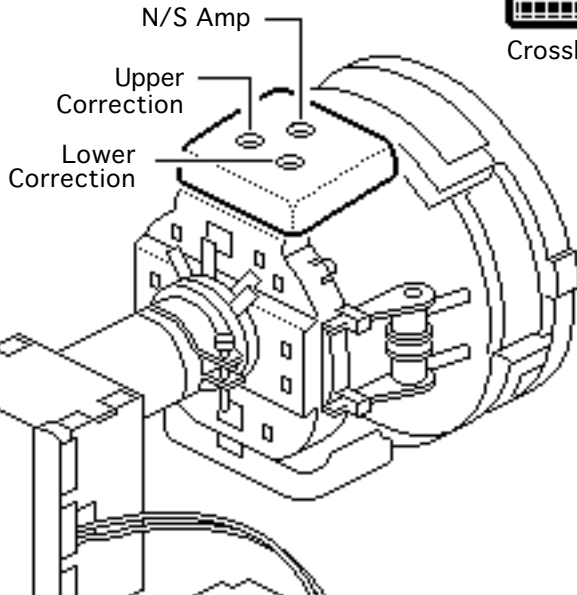

Crosshatch I

- 3 Using a hex-head plastic adjustment tool, adjust the N/S amp control for best convergence of horizontal lines at the top and bottom of the screen.
- 4 Adjust the lower correction control for best convergence of vertical lines at the bottom of the screen.
- 5 Adjust the upper correction control for best convergence of vertical lines at the top of the screen.





Geometric Distortion

Before you begin, remove the rear housing.

⚠ Warning: This product contains high voltage and a high-vacuum picture tube. To prevent serious injury, review CRT safety in Bulletins/Safety.

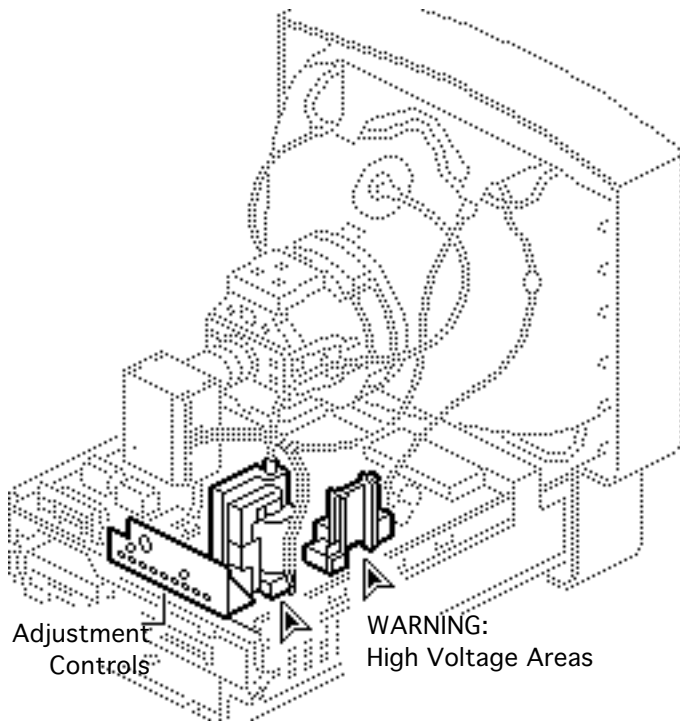

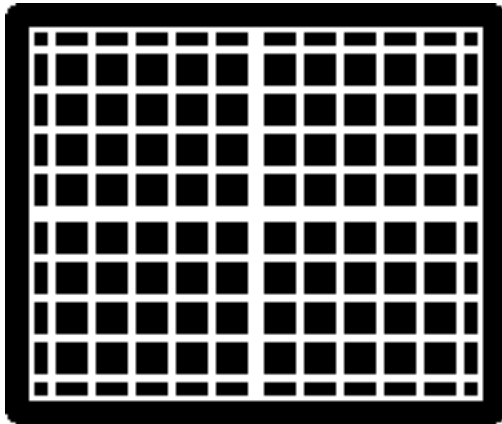

Crosshatch I

- 1 Use Display Service Utility to display the Crosshatch I test pattern.
- 2 Verify that the boxes on the top row are the same size as the boxes on the bottom row, and the boxes on the left side are the same size as the boxes on the right side.



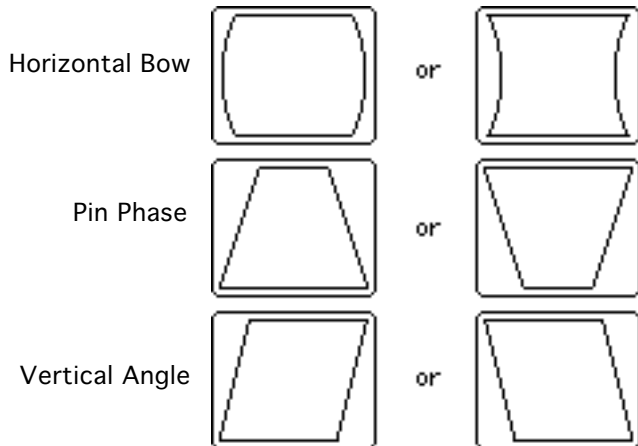

⚠ Warning: The entire yoke assembly has very high voltage. To prevent electrical shock, do not touch the yoke assembly, the anode wire, or the yoke wires.

- 3 To determine which control to adjust, compare the display with the distortions shown.
- 4 Using a hex-head plastic adjustment tool, adjust the control (see next page for control locations).



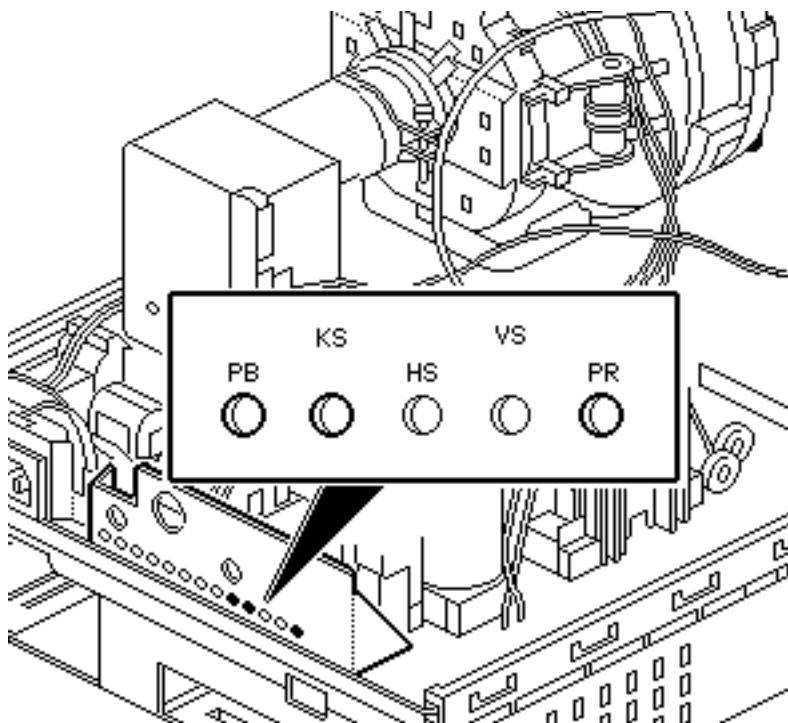

- 5 Using a hex-head plastic adjustment tool, adjust the control that is appropriate for the distortion.
- 6 If the display is so distorted that you can't tell which adjustments to make, perform the adjustments in the following sequence:
 - Pin Phase (KS)
 - Vertical Angle (PR)
 - Horizontal Bow (PB)



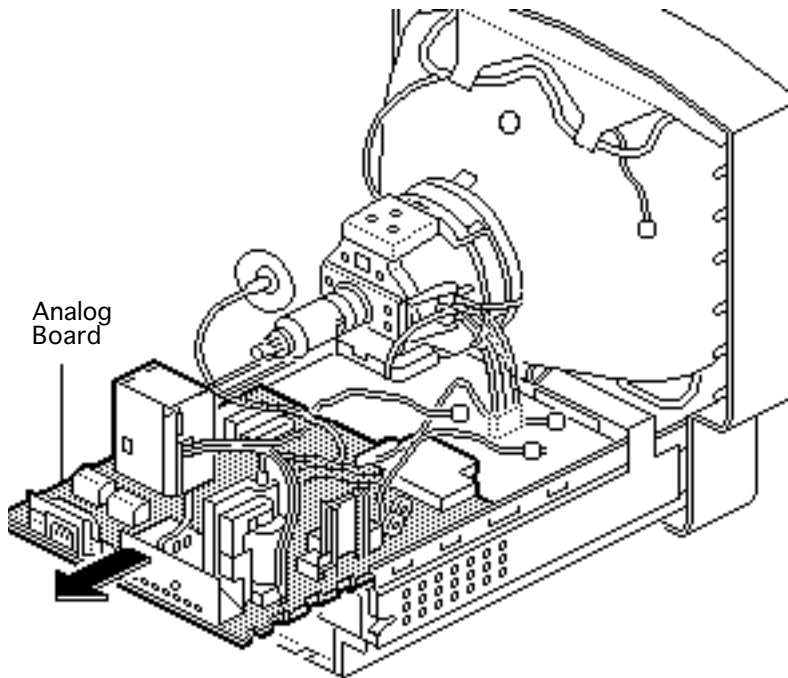

- 7 If the display is still distorted, repeat the vertical angle and pin phase adjustments.
- 8 If you can't correct the distortion, replace the analog board. See "Analog Board" in the Take Apart chapter.



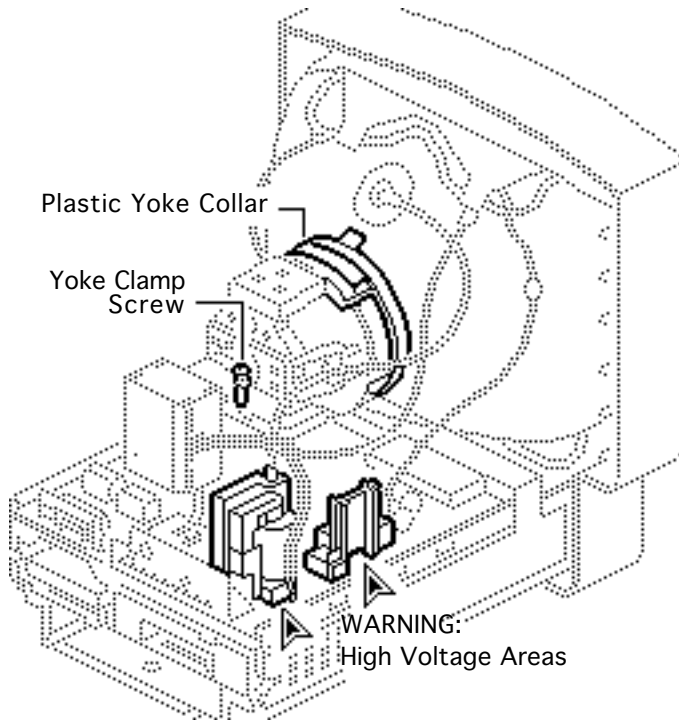

Yoke

Before you begin, remove the rear housing.

⚠ Warning: This product contains high voltage and a high-vacuum picture tube. To prevent serious injury, review CRT safety in Bulletins/Safety.



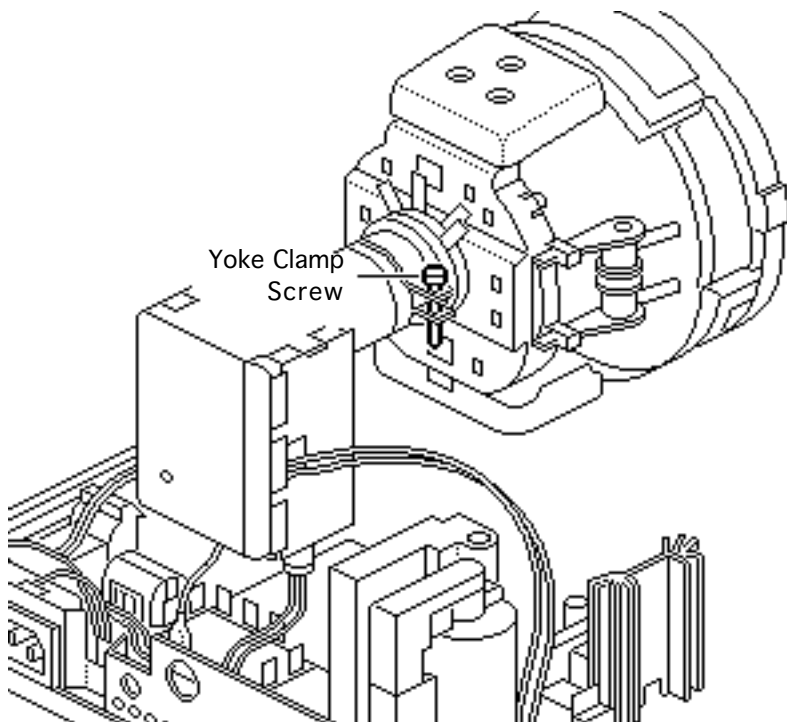

⚠ Warning: Because you must make yoke adjustments from the rear of the computer, use a mirror to view the computer screen. Do not reach around the computer to adjust collars and rings.

Note: If you replace the CRT, you will probably need to adjust the yoke.

- 1 Using an insulated Philips screwdriver, loosen the yoke clamp screw two or three turns.





Plastic Yoke Collar

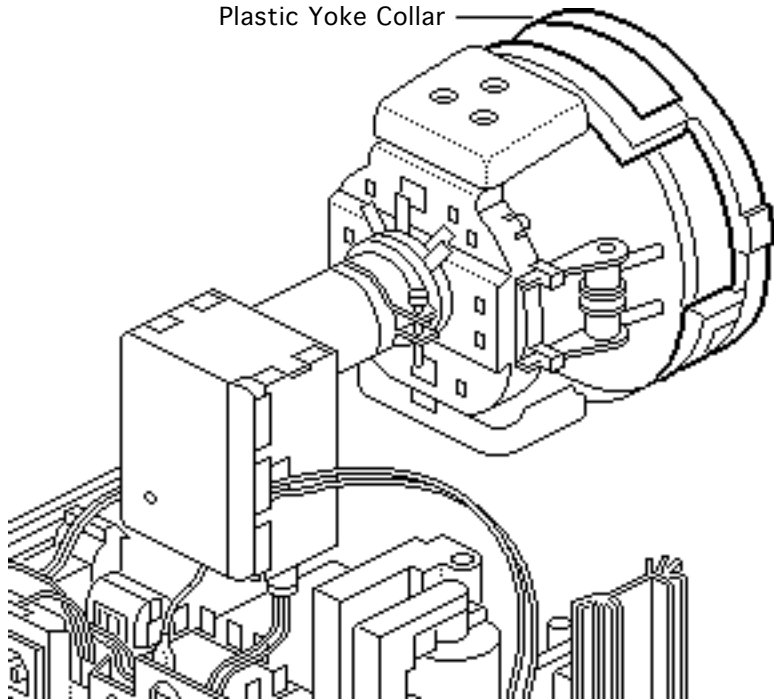

- 2 Switch on the computer.
- 3 With one hand, grasp the plastic yoke collar and rotate it until the top and bottom edges of the picture are parallel with the top and bottom of the bezel. Switch off and unplug the computer.
- 4 Discharge the CRT.



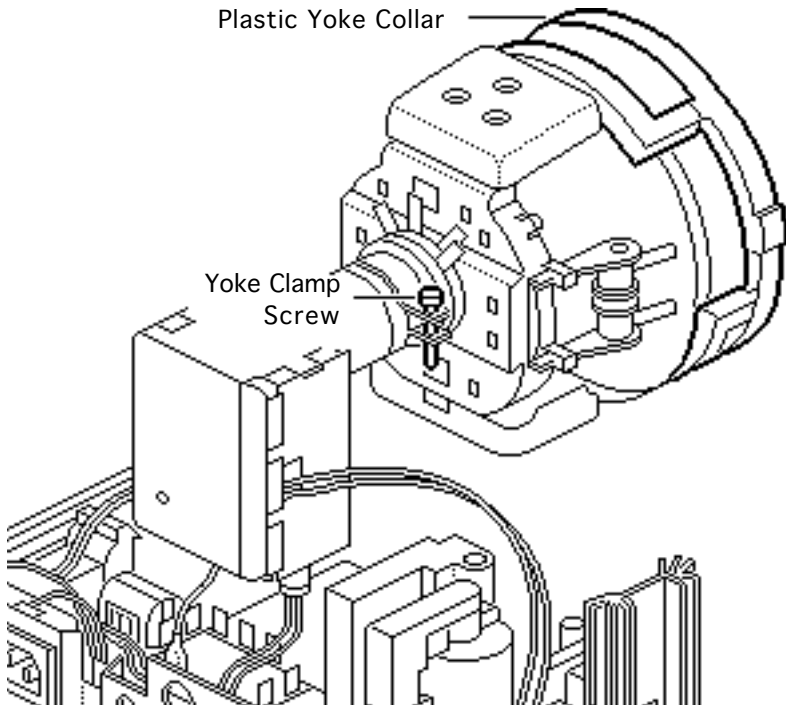

- 5 Hold the plastic yoke collar in position and carefully tighten the yoke clamp screw so that the collar cannot slip. Do not overtighten the screw.
- 6 Replace the rear housing and switch on the computer.
- 7 Verify that the top and bottom edges of the picture are parallel with the top and bottom of the bezel.





Exploded View

Performa 500 Series



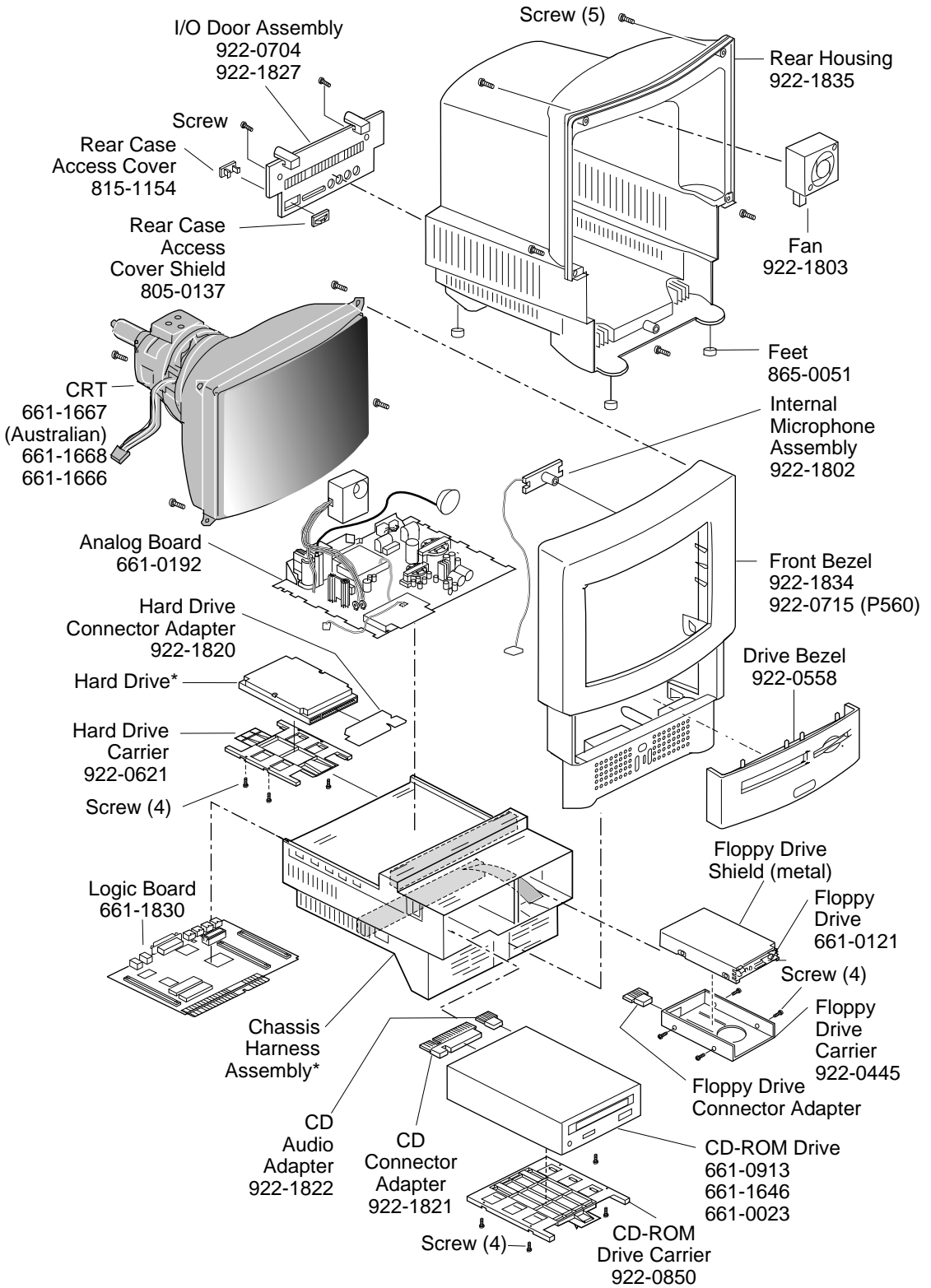

***This is a generic representation of a product family. Configurations may vary.
For number of part with asterisk, see parts list.***

